

**NKV**

MULTISTAGE CENTRIFUGAL ELECTRIC PUMPS WITH VERTICAL AXIS

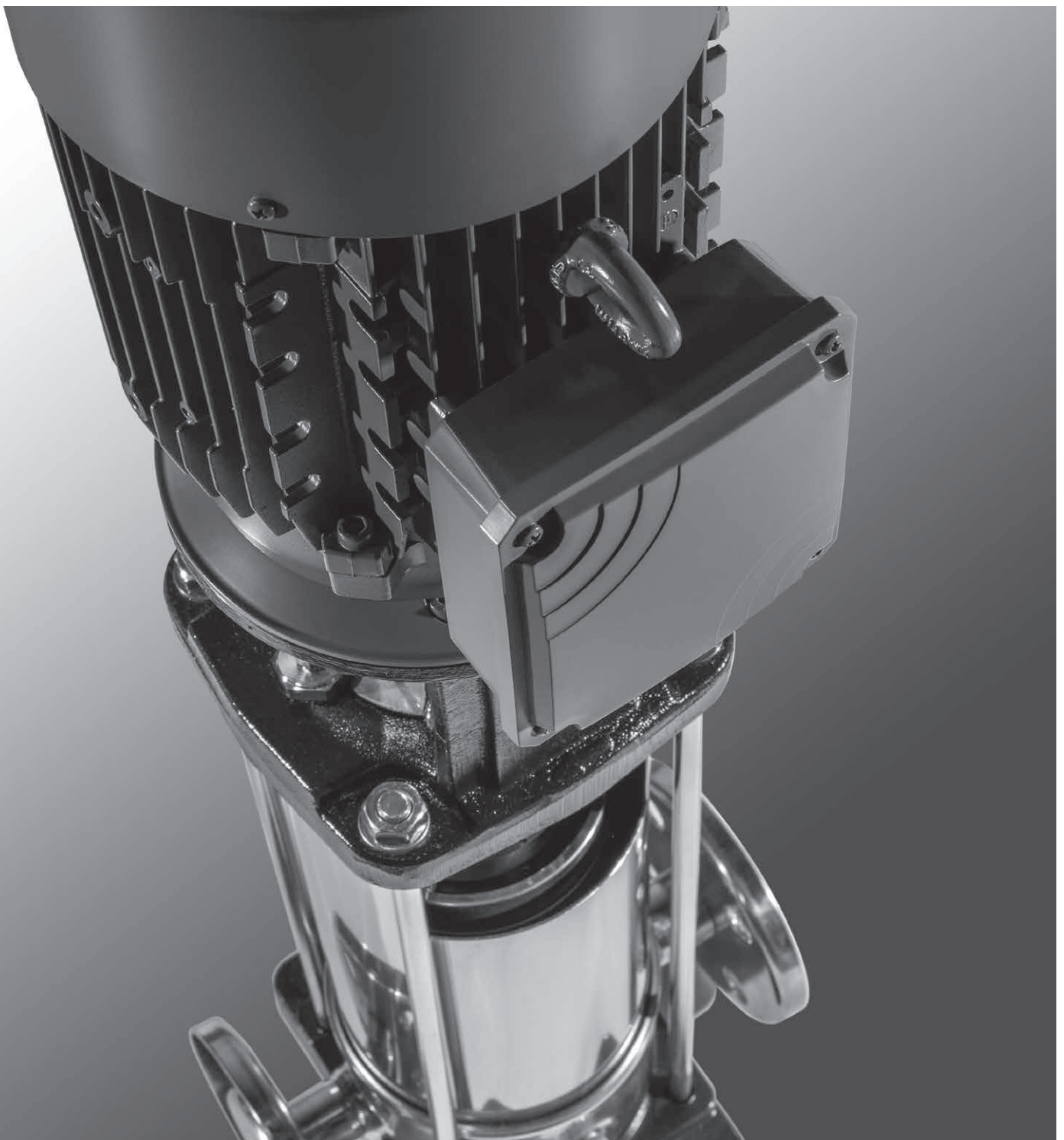



### TECHNICAL DATA

**Operating range :**

NNKV 1, 3, 6, 10, 15, 20 S: from 1 m<sup>3</sup>/h to 30 m<sup>3</sup>/h with head up to 320 m

NKV 32, 45, 65, 95: from 1 m<sup>3</sup>/h to 120 m<sup>3</sup>/h with head up to 320 m

**Type of pumped liquid:** Clean, free from solid or abrasive substances, non-viscous, non-aggressive, non-crystallized and chemically neutral

**Maximum percentage of glycol:** 30%

**Supported liquid temperature min. and max.:** From -30 to +120°C (EPDM)  
From -15°C to +120°C (Viton/FKM)

**Maximum ambient temperature:** +50° C

**Maximum operating pressure bar / kPa:**

NKV from 1 S to 20 S: 25 bar / 2500 kPa

NKV 32, 45: 32 bar / 3200 kPa

NKV 65, 95: 25 bar / 2500 kPa

**Degree of protection of the engine:** IP 55

**Engine insulation class:** F

**Impellers construction material:** AISI 304 stainless steel

On request X version with AISI 316 stainless steel.

**Single phase power supply (on request):**

220 - 240 / 380 - 415 V at 50 Hz up to 2,2 kW

**Three-phase power supply:**

220 - 240 / 380 - 415 V at 50 Hz up to 2,2 kW

380 - 415 V at 50 Hz from 3 kW

**Power cord (m) and plug:** Not provided

**Type of installation possible:** Vertical position

**Special versions available on request:**

- different types of mechanical seals (for example for aggressive liquids)
- connections (round flanges, oval, Victaulic, clamp)
- parts in contact with the liquid in stainless steel AISI 316 (versions X)
- different voltages and frequencies
- ATEX version

**Certifications:** NKV from 1 S to 20 S or X: WRAS, ACS

NKV from 32 to 95 X version: WRAS, ACS

### APPLICATIONS

NKV are AISI 304 stainless steel multi-impeller vertical centrifugal pumps with coupling; designed for pressurization, conditioning and heating in civil and commercial environments, they can also be used in agriculture and in watering systems. The pumps can be used for the recirculation of water in heating and air conditioning systems.

#### CONSTRUCTION FEATURES OF THE PUMP - NKV 1-3-6-10-15-20 S

The use of advanced stainless steel processing technologies for the main hydraulic components helps to achieve very high performance levels. The pumps are also extremely versatile, thanks to the center distance of the in-line ports, designed to maximize interchangeability. The parts in contact with the liquid are made of AISI 304 stainless steel for NKV S models, or AISI 316 stainless steel for NKV X models (only available to special order). Round flanges as standard (oval, loose, virtual, clamp available on request). The mechanical seal is made of standard E1 = Graphite/Silicon Carbide/AISI 316/EPDM = BQGE. FKM/Viton available on request. Starting from 5.5 kW models, the seal can be removed without removing the motor. Rigid coupling

#### CONSTRUCTION FEATURES OF THE PUMP - NKV 32-45-65-95

The use of advanced stainless steel processing technologies for the main hydraulic components helps to achieve very high performance levels. They are extremely versatile, thanks to the center distance of the in-line ports, designed to maximize interchangeability. Their pump body and upper flange are in cataphoretic paint coated cast iron; impellers, diffusers and pump liner made of AISI 304 stainless steel (AISI 316 stainless steel available on request - X version). Round flanges as standard (oval, loose, virtual, clamp available on request). The mechanical seal is made of standard E1 = Graphite/Silicon Carbide/AISI 316/EPDM = BQGE. FKM/Viton available on request. Starting from 5.5 kW models, the seal can be removed without removing the motor. Rigid coupling.

#### CONSTRUCTION FEATURES OF THE MOTOR

Standard mechanical seal E1 (= Graphite/ Silicon Carbide/AISI 316/EPDM) and on request among the various custom seals there are also with FKM/Viton. The seal can be dismantled without removing the motor from 5.5 kW. Rigid coupling. Motor frame B14 up to 4 kW motor size and B5 from 5,5 kW motor size.

#### - Denomination index:

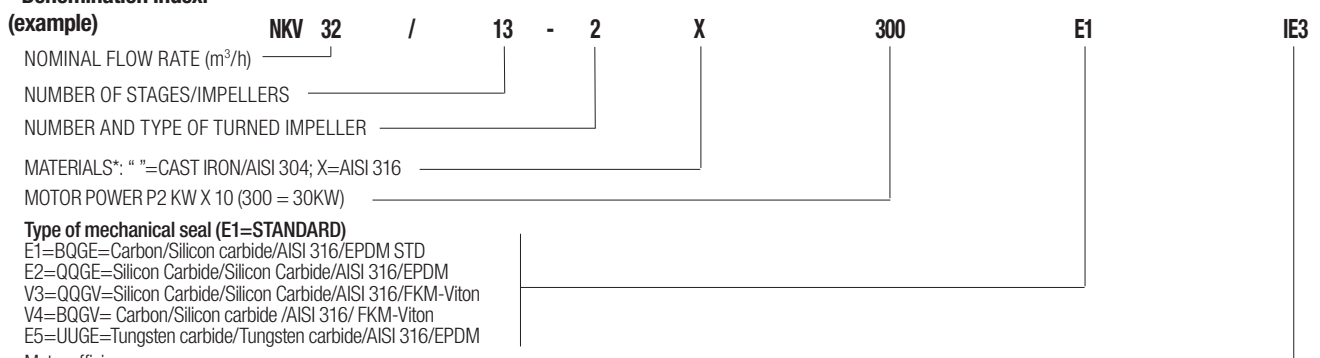

\*MATERIALS:

"S" version with pump body/impellers/diffusers in AISI 304 stainless steel - "X" version with pump body/impellers/diffusers in AISI 316 stainless steel

" " standard version with pump body in cast iron and impellers in AISI 304 stainless steel (for NKV 32-45-65-95)

### NKV 1-3-6-10-15-20 MATERIAL

N°	PART	MATERIAL* (S VERSION - AISI 304)	MATERIAL* (X VERSION - AISI 316)
1	Pump body	Stainless Steel AISI 304	Stainless Steel AISI 316
2	Upper flange	Stainless Steel AISI 304	Stainless Steel AISI 316
3	Impeller	Stainless Steel AISI 304	Stainless Steel AISI 316
4	Diffuser body and diffuser	Stainless Steel AISI 304	Stainless Steel AISI 316
5	Pump shaft	Stainless Steel AISI 304	Stainless Steel AISI 316
7	Initial stage housing	Stainless Steel AISI 304	Stainless Steel AISI 316
8	Stage centering outlet	Stainless Steel AISI 304	Stainless Steel AISI 316
9	Mechanical seal	Carbon/Silicon carbide/AISI 316/ EPDM	Carbon/Silicon carbide/AISI 316/ EPDM
10	Discharge plug	Stainless Steel AISI 304	Stainless Steel AISI 316
11	O-ring	EPDM	EPDM
12	Seal disk	Stainless Steel AISI 304	Stainless Steel AISI 316
13	Filling plug	Stainless Steel AISI 304	Stainless Steel AISI 316
14	Stage housing and diffuser with bearing	Stainless Steel AISI 304/Tungsten carbide	Stainless Steel AISI 316/Tungsten carbide
15	External sleeve	Stainless Steel AISI 304	Stainless Steel AISI 316
16	Floating wear ring	PPS	PPS
17	Intermediate bushing	Tungsten carbide	Tungsten carbide

\* In contact with the liquid.

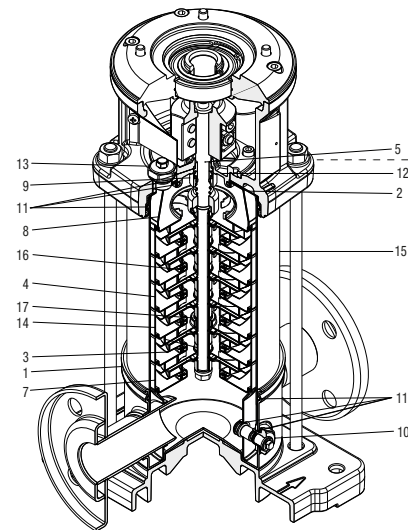
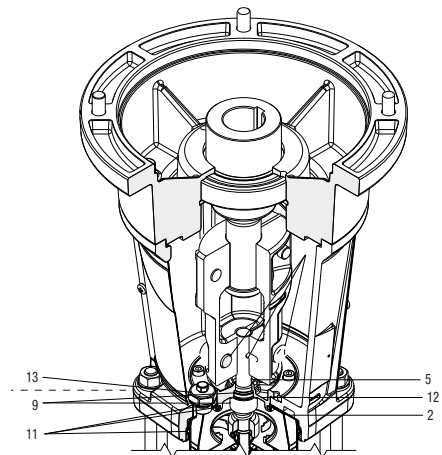

### NKV 32-45-65-95 MATERIAL

N°	PART	MATERIAL* (STANDARD VERSION)	MATERIAL* (X VERSION - AISI 316)
1	Pump body	Cast iron with cataphoresis	Stainless Steel AISI 316
2	Upper flange	Stainless Steel AISI 304	Stainless Steel AISI 316
3	Impeller	Stainless Steel AISI 304	Stainless Steel AISI 316
4	Diffuser body and diffuser	Stainless Steel AISI 304/Carbon	Stainless Steel AISI 316/Carbon
5	Pump shaft	Stainless Steel AISI 431	Stainless Steel AISI 329
6	Stage centering inlet	Stainless Steel AISI 316	Stainless Steel AISI 316
7	Stage centering outlet	Stainless Steel AISI 304	Stainless Steel AISI 316
8	Mechanical seal	Carbon/Silicon carbide/AISI 316/ EPDM	Carbon/Silicon carbide/AISI 316/ EPDM
9	Discharge plug	Stainless Steel AISI 304	Stainless Steel AISI 316
10	O-ring	EPDM	EPDM
11	Seal disk	Stainless Steel AISI 304	Stainless Steel AISI 316
12	Filling plug	Stainless Steel AISI 304	Stainless Steel AISI 316
13	Stage housing and diffuser with bearing	Stainless Steel AISI 304	Stainless Steel AISI 316
14	External sleeve	Stainless Steel AISI 304	Stainless Steel AISI 316
15	Floating wear ring	PTFE	PTFE
16	Intermediate bushing	Stainless Steel AISI 316/Tungsten carbide	Stainless Steel AISI 316/Tungsten carbide

\* In contact with the liquid.

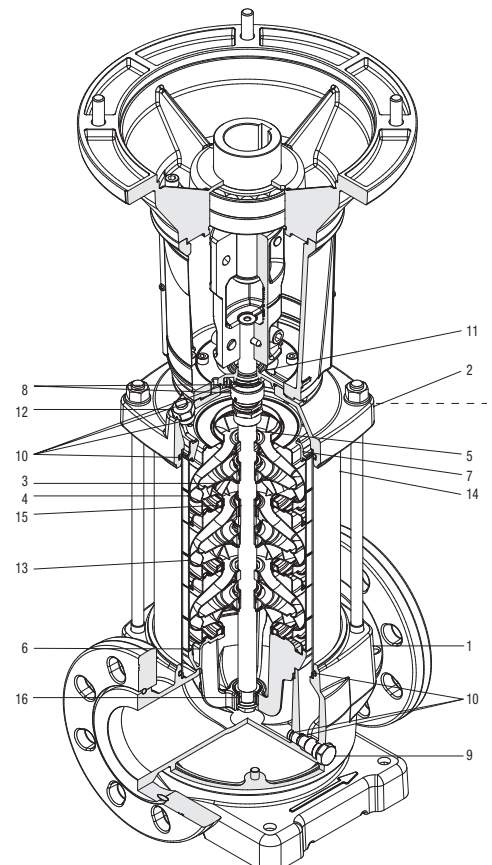

## MATERIAL TABLE SELECTION

PUMP MODEL	IMPELLER / DIFFUSER	BASE	FLANGES
NKV 32, 45, 65, 95	Inox 304	Cast iron	Cast iron
NKV 1, 3, 6, 10, 15, 20 S	Inox 304	Inox 304	Inox 304
NKV 1, 3, 6, 10, 15, 20, 32, 45, 65, 95 X	Inox 316	Inox 316	Inox 316

## LIQUID TABLE SELECTION

Type of mechanical seal (E1=STANDARD)

E1=BQGE=Carbon/Silicon carbide/AISI 316/EPDM STD

E2=QQGE=Silicon Carbide/Silicon Carbide/AISI 316/EPDM

V3=QQGV=Silicon Carbide/Silicon Carbide/AISI 316/FKM-Viton

V4=BQGV= Carbon/Silicon carbide /AISI 316/ FKM-Viton

E5=UUGE=Tungsten carbide/Tungsten carbide/AISI 316/EPDM

LIQUID (WATER SOLUTION)	CONCENTRATION [%]	MIN/MAX TEMPERATURE [°C]	NKV MODEL		
			STANDARD (NKV 32-95)	S (NKV 1-20)	X (NKV 1-95)
Acetic acid	10 ÷ 40	+0/+70	-	-	E1
Citric Acid	5	+5/+70	-	E1	E1
Hydrochloric Acid	2	+5/+25	-	-	V3
Formic Acid	5	+5/+25	-	E1	E1
Phosphoric Acid	10	+5/+30	-	-	E1
Nitric Acid	40	+5/+30	-	V3	V3
Sulfuric Acid	2	+5/+25	-	-	V4
Tannic Acid	20	+5/+50	-	-	E1
Tartaric Acid	50	+5/+25	-	V3	V3
Deionized Water, Demineralized	100	+5/+110	E1	E1	E1
Sodium Bicarbonate	6	+5/+60	-	-	E1
Chloroform	100	-10/+30	V4	V4	V4
Oil In Water Emulsion	100	+15/+90	V4	V4	V4
Phosphates, Polyphosphates	10	+5/+90	-	V3	V3
Ethylene Glycol	10 ÷ 30	-15/+120	-	E1	E1
Propylene Glycol	30	-10/+100	V3	V3	V3
Sodium Hypochlorite	1	+5/+25	-	-	V3
Sodium Nitrate	10	+5/+60	-	V3	V3
Diathermic Oil	100	+90/+120	V4	V4	V4
Mineral Oil	100	+90/+120	V4	V4	V4
Vegetable Oil	100	+70/+100	E1	E1	E1
Perchloroethylene	100	-10/+30	V4	V4	V4
Sodium Hydroxide	25	+5/+70	E2	E2	E2
Aluminium Sulphate	10 ÷ 25	+5/+50	-	-	E2
Ammonium Sulphate	10	-10/+60	-	-	E2
Ferric Sulphate	10	+5/+30	-	-	E1
Trichloroethylene	100	-10/+40	V4	V4	V4

For use with sea water, please consult the technical office. This table should be considered a general guide.

It is important to consider the specific operating conditions, in particular the concentration in the pumped liquid, the specific weight and/or the viscosity, the temperature of the liquid and its pressure.

All these conditions are essential for engine and pump performance.

When pumping hazardous liquids, it is recommended to take safety precautions. You can contact us for more information.

### PERFORMANCE RANGE

The performance curves are based on the kinematic viscosity values = 1 mm<sup>2</sup>/s and density equal to 1000 kg/m<sup>3</sup>. Curve tolerance according to ISO 9906.

### GRAPHICAL SELECTION TABLE

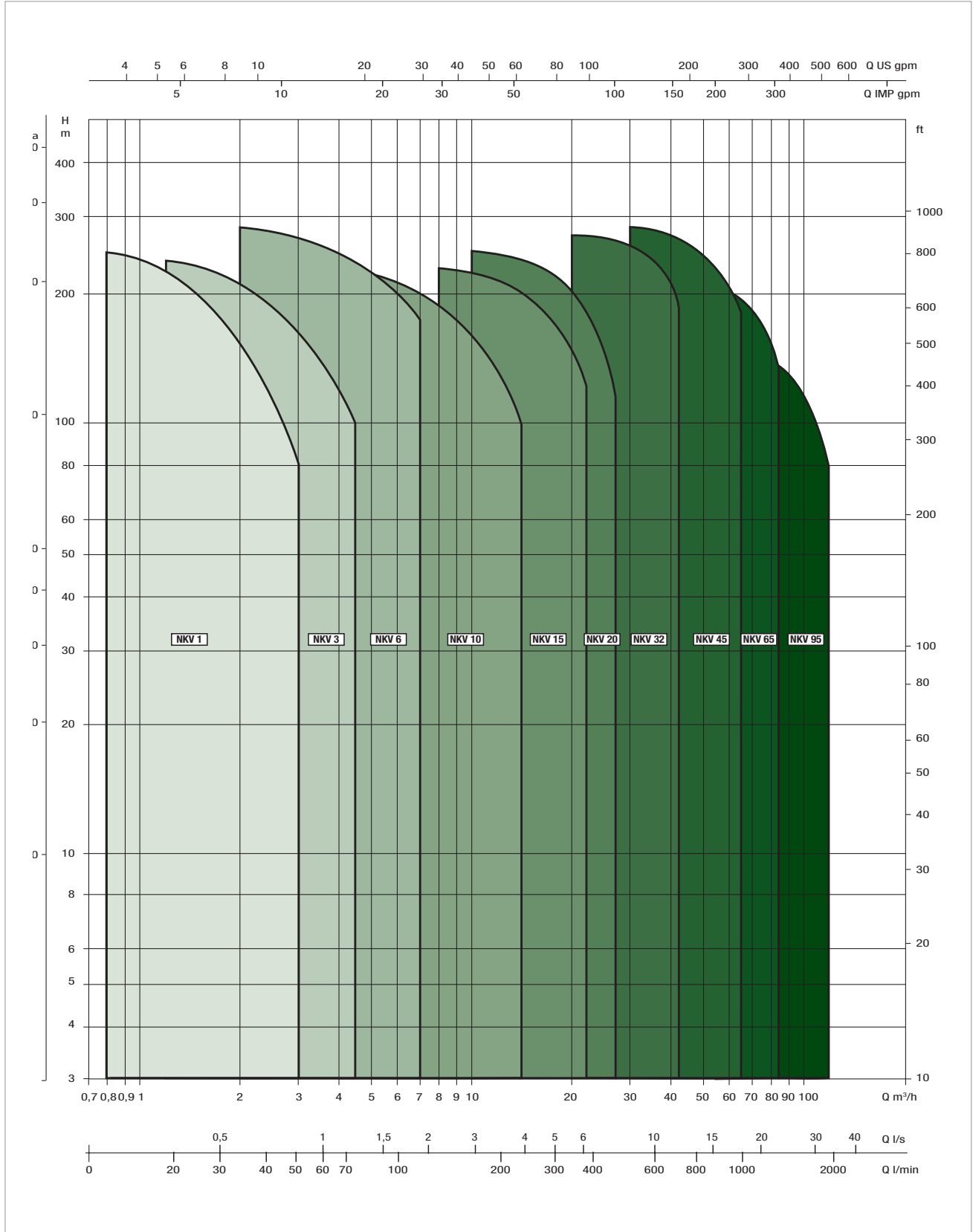

### SELECTION TABLE - NKV 1

MODEL	Q=m³/h	0	0.5	1	1.5	2	2.5
	Q=l/min	0	8.3	16.7	25.0	33.3	42
NKV 1/2 T IE3	H (m)	14.5	13.5	12.5	11.5	9.5	7.5
NKV 1/3 T IE3		21.5	20	19	17	14	11
NKV 1/4 T IE3		28	26.5	24.5	22	18.5	14
NKV 1/5 T IE3		35	33	30.5	27	22.5	17
NKV 1/6 T IE3		41.5	39	36	32	26.5	19.5
NKV 1/7 T IE3		48	45	41.5	36.5	30	22
NKV 1/8 T IE3		55	52	48	42.5	35	26
NKV 1/9 T IE3		61.5	58	53	47	39	28.5
NKV 1/10 T IE3		68	64	58.5	51.5	43	31.5
NKV 1/11 T IE3		74.5	69.5	64	56.5	46.5	34
NKV 1/12 T IE3		83	78.5	72	64	53	39.5
NKV 1/13 T IE3		89.5	84.5	77.5	68.5	57	42
NKV 1/14 T IE3		96	90.5	83	73	60.5	44.5
NKV 1/15 T IE3		102.5	96	88	78	64	47
NKV 1/17 T IE3		118	111.5	103	91.5	76	56.5
NKV 1/19 T IE3		131	123.5	114	101	84	62
NKV 1/22 T IE3		150.5	141.5	130	115	95	69.5
NKV 1/23 T IE3		160.5	152	140	124.5	104	77.5
NKV 1/25 T IE3		174	164	151.5	134.5	112	83.5
NKV 1/27 T IE3		187	176.5	162.5	144	120	88.5
NKV 1/30 T IE3	206.5	194.5	179	158	131	96.5	
NKV 1/32 T IE3	224.5	213	197	175.5	147.5	110.5	
NKV 1/34 T IE3	238	225.5	208.5	185.5	155.5	116.5	
NKV 1/37 T IE3	258	244	225.5	200.5	167.5	125	

### SELECTION TABLE - NKV 3

MODEL	Q=m³/h	0	1	1.5	2	2.5	3	3.5	4	4.5
	Q=l/min	0	16.7	25.0	33.3	42	50.0	58.3	67	75.0
NKV 3/2 T IE3	H (m)	15	15	14.5	13.5	12.5	11.5	10	8	6
NKV 3/3 T IE3		22.5	22	21	20	18.5	17	14.5	12	8.5
NKV 3/4 T IE3		30	28.5	27.5	26	24	21.5	18.5	15	10.5
NKV 3/5 T IE3		37.5	36	34.5	32.5	30	27	23.5	18.5	13
NKV 3/6 T IE3		44.5	42.5	40.5	38.5	35.5	32	27	21.5	15
NKV 3/7 T IE3		52.5	50.5	48.5	46	43	38.5	33	26.5	19
NKV 3/8 T IE3		59.5	57.5	55	52	48	43.5	37	29.5	21
NKV 3/9 T IE3		67	64	61.5	58	53.5	48	41	32.5	22.5
NKV 3/10 T IE3		75	72.5	70	66.5	61.5	55.5	48	38.5	27.5
NKV 3/11 T IE3		82.5	79.5	76.5	72.5	67	60.5	52	42	29.5
NKV 3/12 T IE3		89.5	86	83	78.5	72.5	65	56	45	31.5
NKV 3/13 T IE3		96.5	93	89	84.5	78	70	60	47.5	33.5
NKV 3/14 T IE3		105.5	102	98.5	93.5	86.5	78	67.5	54.5	39.5
NKV 3/15 T IE3		112.5	109	105	99.5	92.5	83	71.5	58	41.5
NKV 3/16 T IE3		120	115.5	111.5	105.5	98	88	76	61	43.5
NKV 3/17 T IE3		127	122.5	118	111.5	103.5	93	80	64	45.5
NKV 3/18 T IE3		136.5	132.5	128	121.5	113.5	102.5	89	72.5	53
NKV 3/19 T IE3		144	139.5	134.5	128	119	107.5	93.5	76	55.5
NKV 3/21 T IE3		158.5	153.5	148	140.5	130.5	118	102	83	60
NKV 3/23 T IE3		173	167.5	161.5	153	142	128	110.5	89.5	64.5
NKV 3/25 T IE3	187.5	181	174.5	165.5	153.5	138	119	96	68.5	
NKV 3/27 T IE3	205.5	199.5	193	184	171.5	155	135	110.5	81	
NKV 3/29 T IE3	220	213.5	206.5	196.5	183.5	166	144	117.5	86	
NKV 3/31 T IE3	235	228	220.5	209.5	195	176.5	153	124.5	91	
NKV 3/33 T IE3	249.5	242	234	222	206.5	187	162	131.5	95.5	

### SELECTION TABLE - NKV 6

MODEL	Q=m³/h	0	2.5	3	3.5	4	4.5	5	5.4	6	7
	Q=l/min	0	42	50.0	58.3	67	75.0	83.3	90	100.0	116.7
NKV 6/2 T IE3	H (m)	15	14	13.5	13	12.5	12	11.5	11	10	8
NKV 6/3 T IE3		22.5	20.5	19.5	19	18	17	16	15.5	14	11
NKV 6/4 T IE3		29.5	27	26	25	24	22.5	21.5	20.5	18.5	14.5
NKV 6/5 T IE3		37.5	34.5	33.5	32	30.5	29	27.5	26	24	19
NKV 6/6 T IE3		44.5	41	39.5	37.5	36	34	32.5	30.5	28	22
NKV 6/7 T IE3		52.5	49	47	45	43	41	39	37	34	27
NKV 6/8 T IE3		59.5	55	53.5	51	48.5	46.5	44	42	38.5	30.5
NKV 6/9 T IE3		67	61.5	59	56.5	54	51.5	48.5	46	42.5	33.5
NKV 6/10 T IE3		75	70	67.5	65	62	59	56	53.5	49	39
NKV 6/11 T IE3		82.5	76.5	73.5	71	67.5	64.5	61	58	53.5	42.5
NKV 6/12 T IE3		89.5	83	80	76.5	73	69.5	65.5	62.5	57.5	45.5
NKV 6/13 T IE3		97	89	86	82	78.5	74.5	70.5	67	61.5	48.5
NKV 6/14 T IE3		105.5	99	95.5	92	88	83.5	79.5	76	70	56
NKV 6/15 T IE3		113	105.5	102	98	93.5	89	84.5	80.5	74	59.5
NKV 6/16 T IE3		120.5	112	108	104	99	94.5	89.5	85.5	78.5	62.5
NKV 6/17 T IE3		127.5	118.5	114.5	109.5	105	99.5	94.5	90	83	66
NKV 6/18 T IE3		135	125	120.5	115.5	110.5	105	99.5	94.5	87	69
NKV 6/19 T IE3		142	131.5	126.5	121.5	115.5	110	104	99	91	72
NKV 6/20 T IE3		152	142.5	138	133	127	121	115	110	101.5	82
NKV 6/21 T IE3		159	149.5	144.5	139	133	127	120.5	115	106	85.5
NKV 6/23 T IE3		174	163	157.5	151.5	144.5	138	131	125	115	92.5
NKV 6/25 T IE3		189	175.5	170	164	157.5	150.5	142.5	135.5	123.5	98.5
NKV 6/28 T IE3		214	200.5	194.5	188	181	173.5	164.5	156.5	143	115.5
NKV 6/30 T IE3		229	214	207.5	200.5	193	184.5	175.5	167	152.5	122.5
NKV 6/33 T IE3		251.5	234.5	227	219.5	211	201.5	191	182	166	133.5
NKV 6/36 T IE3		275	257.5	249.5	241.5	232.5	222.5	211.5	201.5	184	148.5

### SELECTION TABLE - NKV 10

MODEL	Q=m³/h	0	6	7	8	9	10	11	14
	Q=l/min	0	100.0	116.7	133	150.0	166.7	183	233.3
NKV 10/2 T IE3	H (m)	20	18.5	17.5	17	16	15	13.5	9
NKV 10/3 T IE3		30	27.5	26.5	25.5	24	22.5	20.5	13.5
NKV 10/4 T IE3		40.5	37	35.5	34	32.5	30.5	28	18
NKV 10/5 T IE3		50.5	45.5	43.5	41.5	39.5	37	33.5	21.5
NKV 10/6 T IE3		61	56	54	51.5	49	46	42	27.5
NKV 10/7 T IE3		70.5	64.5	62	59.5	56	52.5	48	31
NKV 10/8 T IE3		81.5	75.5	73	70	66.5	62.5	57.5	38
NKV 10/9 T IE3		91.5	84.5	81.5	78	74	69.5	64	42
NKV 10/10 T IE3		102.5	96	93	89	84.5	79.5	73.5	49
NKV 10/11 T IE3		113	105	101.5	97.5	92.5	87	80.5	53.5
NKV 10/12 T IE3		123	114	110	105.5	100.5	94	87	57.5
NKV 10/13 T IE3		133	123	118.5	113.5	108	101	93.5	61.5
NKV 10/15 T IE3		153.5	142.5	138	132	125.5	118	109	72
NKV 10/17 T IE3		173.5	160.5	155	148.5	141	132.5	122	80.5
NKV 10/19 T IE3		195	182	176	169	160.5	151	139.5	93
NKV 10/21 T IE3		215.5	200	193.5	185.5	176.5	166	153	101.5
NKV 10/23 T IE3		235.5	218.5	211	202	192	180.5	166.5	110
NKV 10/24 T IE3		248	234	227	218	208	196	182	122.5

### SELECTION TABLE - NKV 15

MODEL	Q=m³/h	0	8	10	12	14	16	18	20	22	24
	Q=l/min	0	133	167	200	233	266	300	333	367	400
NKV 15/1 T IE3	H (m)	14.5	13	12.5	12	11.5	10.5	9.5	8.5	7	5.5
NKV 15/2 T IE3		29	26	25	24	23	21.5	19.5	17	14	11
NKV 15/3 T IE3		43.5	39	38	36.5	34.5	32.5	29.5	26	21.5	17
NKV 15/4 T IE3		58	52.5	51	49	46.5	44	40.5	35.5	29.5	23.5
NKV 15/5 T IE3		72.5	65.5	63.5	60.5	57.5	54.5	49.5	43	36	28.5
NKV 15/6 T IE3		87.5	79.5	77	74	71	67	61.5	54	46	36.5
NKV 15/7 T IE3		102	92	89	86	82	77.5	70.5	62	52.5	41.5
NKV 15/8 T IE3		117	106.5	103	99.5	95	90	82.5	72.5	62	49
NKV 15/9 T IE3		131.5	119	115.5	111	106	100.5	92	81	69	54.5
NKV 15/10 T IE3		147.5	134.5	131	126.5	121	115	106	94	80.5	65
NKV 15/11 T IE3		162	148	143.5	139	133	126.5	116.5	103	88.5	71
NKV 15/12 T IE3		176.5	161	156.5	151	144.5	137.5	126.5	112	96	77
NKV 15/13 T IE3		191	174.5	169	163.5	156.5	148.5	136.5	120.5	103	82.5
NKV 15/14 T IE3		205.5	187.5	182	175.5	168	159	146	129	110.5	88
NKV 15/15 T IE3		221	201	195.5	188.5	180.5	171.5	157.5	139.5	119.5	95.5
NKV 15/16 T IE3		235.5	214	208	200.5	192	182.5	167.5	148	126.5	101.5
NKV 15/17 T IE3		249.5	227.5	220.5	213	203.5	193	177.5	156.5	134	107

### SELECTION TABLE - NKV 20

MODEL	Q=m³/h	0	10	12	14	16	18	20	22	24	26	28
	Q=l/min	0	167	200	233	266	300	333	367	400	433.5	466.5
NKV 20/1 T IE3	H (m)	15.5	13.5	13	13	12.5	12	11	10	8.5	7.5	6
NKV 20/2 T IE3		31	27.5	27	26	25	24	22.5	20.5	18	15	12
NKV 20/3 T IE3		46.5	41.5	40.5	39.5	38	36.5	34.5	31	27.5	23	18.5
NKV 20/4 T IE3		62.5	56	55	53.5	51.5	49.5	46.5	42.5	37	31.5	25.5
NKV 20/5 T IE3		78	70	68.5	66.5	64.5	62	58	53	47	40	32.5
NKV 20/6 T IE3		94.5	86.5	84.5	82.5	80	77.5	73.5	67.5	60	52	42.5
NKV 20/7 T IE3		110	100.5	98	95.5	93	90	85	77.5	69	59.5	48.5
NKV 20/8 T IE3		126.5	117	114	112	109	106	100.5	92.5	82.5	72	59.5
NKV 20/9 T IE3		142.5	131	128	125.5	122	118.5	112.5	103.5	92.5	80.5	66.5
NKV 20/10 T IE3		158	145.5	142	139	135	131.5	124.5	114	102	88.5	73
NKV 20/11 T IE3		174	160	156.5	153	149	144.5	137	126	113	98	81
NKV 20/12 T IE3		189.5	174.5	170.5	167	162	157.5	149	137	122.5	106.5	87.5
NKV 20/13 T IE3		205	188.5	184	180	175	170	161	147.5	132	114.5	94
NKV 20/14 T IE3		220.5	202.5	198	193.5	188	182.5	172.5	158	141	122	100.5
NKV 20/15 T IE3		237	217.5	212.5	208	202	196	185.5	170.5	152	132	108.5
NKV 20/16 T IE3		252.5	231.5	226	221	215	208.5	197	181	161.5	140	115
NKV 20/17 T IE3		268	245.5	240	234.5	227.5	221	209	191.5	171	148	121.5

### SELECTION TABLE - NKV 32

MODEL	Q=m³/h	0	15	18	22	25	30	35	40	45
	Q=l/min	0	250	300	367	417	500	583	667	750
NKV 32/2-2 T IE3	H (m)	36	33,5	32,5	30,5	29,5	26,5	22,5	18	12,5
NKV 32/2 T IE3		48,5	43,5	42,5	41	39,5	36,5	33,5	29	23,5
NKV 32/3-2 T IE3		60	54,5	53	50,5	48	44	38	31,5	23,5
NKV 32/3 T IE3		73	65	63,5	61	59	55	50	43,5	35,5
NKV 32/4-2 T IE3		84,5	76,5	74	70,5	68	62	55	46	35
NKV 32/4 T IE3		98	88	86	83	80,5	75	69	60	49,5
NKV 32/5-2 T IE3		109,5	99,5	97	93	89,5	83	74	63	49,5
NKV 32/5 T IE3		122,5	109,5	107	103,5	100	93,5	85,5	75	61,5
NKV 32/6-2 T IE3		134	121,5	118,5	113,5	109,5	101,5	91	78	61,5
NKV 32/6 T IE3		146,5	131	128	123,5	119,5	111,5	102	89	73
NKV 32/7-2 T IE3		158	142,5	139	133,5	128,5	119	107	91,5	72,5
NKV 32/7 T IE3		171	152,5	149	144	139,5	130	119	103,5	85
NKV 32/8-2 T IE3		182,5	164,5	160	154	148,5	137,5	124	106	84,5
NKV 32/8 T IE3		194,5	174	169,5	164	158,5	147,5	134,5	117	95,5
NKV 32/9-2 T IE3		208,5	188,5	184	177	171	159	144	124,5	100,5
NKV 32/9 T IE3		221	198	194	187,5	181,5	169,5	155,5	136	112
NKV 32/10-2 T IE3		233	210	205	197,5	191	177,5	161	139	112
NKV 32/10 T IE3		246,5	221,5	217	210	203,5	190,5	175	153,5	126,5
NKV 32/11-2 T IE3		258	233,5	228,5	220,5	213	198,5	180,5	156,5	127
NKV 32/11 T IE3		271	243,5	238	230,5	223,5	209	192	168	138,5
NKV 32/12-2 T IE3	282,5	255,5	249,5	241	233	217	197,5	171	139	
NKV 32/12 T IE3	295	265,5	259,5	251	243	227,5	208,5	182,5	150,5	
NKV 32/13-2 T IE3	307	277,5	271	261,5	252,5	235,5	214	185,5	151	
NKV 32/13 T IE3	319,5	287	280,5	271,5	263	246	225,5	197	162,5	

### SELECTION TABLE - NKV 45

MODEL	Q=m³/h	0	15	18	22	25	30	35	40	45	54	60	65	70
	Q=l/min	0	250	300	367	417	500	583	667	750	900	1000	1083	1166
NKV 45/2-2 T IE3	H (m)	38,5	37,5	37	36,5	35,5	34,5	33	31	28,5	23	18,5	14,5	10
NKV 45/2 T IE3		48,5	47,5	47	46	45,5	44	43	41,5	39	34	30,5	26,5	23
NKV 45/3-2 T IE3		63	62	61,5	60,5	59,5	58	56	53,5	50	42	36	30	24
NKV 45/3 T IE3		73,5	72	71	70	69	67	65,5	63	60	52,5	47	41	34
NKV 45/4-2 T IE3		87,5	86	85	83,5	82	80	77,5	74	69,5	59,5	51	43	34
NKV 45/4 T IE3		97,5	96	94,5	93	91,5	89	86,5	84	79,5	69,5	62	54,5	45
NKV 45/5-2 T IE3		112	109,5	108,5	106,5	105	102	99	94,5	89	76,5	66	56	45
NKV 45/5 T IE3		122	119,5	118	115,5	114	111	108	104,5	99	86,5	77	67,5	56
NKV 45/6-2 T IE3		137,5	135	133,5	131	129	126	122	117,5	110,5	95,5	83,5	72	58
NKV 45/6 T IE3		147,5	145	143,5	140,5	138,5	135	131,5	127	121	106	95	83,5	71
NKV 45/7-2 T IE3		162,5	160	158	155,5	153	149,5	145	139,5	132	115	101	87,5	73
NKV 45/7 T IE3		172,5	170	168	165	162,5	158,5	154,5	149,5	142,5	125,5	112	99	83
NKV 45/8-2 T IE3		187	184	182	178,5	176	171,5	167	160,5	152	132	116,5	101	83
NKV 45/8 T IE3		197	194	191,5	188	185,5	181	176,5	170,5	162,5	142,5	127,5	112,5	94
NKV 45/9-2 T IE3		211,5	208	205,5	202	199	194	188,5	181,5	172	149,5	132	114,5	94
NKV 45/9 T IE3		221,5	218	215,5	211,5	208	203	198	191,5	182	160	143	126	106
NKV 45/10-2 T IE3		235,5	231,5	229	225	221,5	216	210	202	191,5	166,5	147	127,5	106
NKV 45/10 T IE3		246	242	239	234	230,5	225	219	212	201,5	177	158	139	117
NKV 45/11-2 T IE3		261	256,5	254	249	245,5	239,5	233	224,5	213	186	164,5	143,5	119
NKV 45/11 T IE3		271	267	263,5	258,5	255	249	242,5	234,5	223,5	196,5	175,5	155	130
NKV 45/12-2 T IE3	285,5	280,5	277,5	272,5	268,5	261,5	254,5	245,5	232,5	203	179,5	156,5	130	
NKV 45/12 T IE3	295,5	290,5	287,5	282	277,5	271	264	255,5	243	213,5	191	168,5	142	
NKV 45/13-2 T IE3	309,5	304,5	301	295,5	291	284	276	266	252,5	220,5	195	170	142	

### SELECTION TABLE - NKV 65

MODEL	Q=m <sup>3</sup> /h	0	30	36	42	45	54	60	72	78	85
	Q=l/min	0	500	600	700	750	900	1000	1200	1300	1417
NKV 65/2-2 T IE3	H (m)	39	37,5	36,5	35,5	35	33	31	25	22	17,5
NKV 65/2 T IE3		56,5	51	49,5	48,5	48	46	45	41	38,5	34,5
NKV 65/3-2 T IE3		67,5	63,5	62	60,5	59,5	56,5	54	46,5	42	35,5
NKV 65/3 T IE3		84,5	76	74	72,5	71,5	69	67	61,5	57,5	51,5
NKV 65/4-2 T IE3		95,5	88,5	86	84	83	79	75,5	66	60,5	52
NKV 65/4 T IE3		113,5	102,5	100	97,5	96,5	92,5	90,5	83	78	70
NKV 65/5-2 T IE3		125	116	113	110,5	109	104,5	101	90	83	72,5
NKV 65/5 T IE3		142	129	125,5	122,5	121	116,5	114	105	98,5	88,5
NKV 65/6-2 T IE3		153	141,5	137,5	134,5	133	127,5	123	110	102	89,5
NKV 65/6 T IE3		170	154	150	147	145	139,5	136	125	117,5	105,5
NKV 65/7-2 T IE3		181,5	166,5	162,5	158,5	156,5	150	145	130,5	120,5	106,5
NKV 65/7 T IE3		199	180,5	175,5	172	169,5	163,5	159,5	147	138	124
NKV 65/8-2 T IE3		210	193	188	184	181,5	174	168,5	152	141,5	125
NKV 65/8 T IE3		227	206	200	196	193,5	186	181,5	167	157	141

### SELECTION TABLE - NKV 95

MODEL	Q=m <sup>3</sup> /h	0	45	54	60	72	78	85	96	108	118
	Q=l/min	0	750	900	1000	1200	1300	1417	1600	1800	1967
NKV 95/2-2 T IE3	H (m)	44,5	43	42	41	38,5	36,5	34	28,5	21,5	15
NKV 95/2 T IE3		62	55,5	53	51,5	49	47,5	45	41	35	28,5
NKV 95/3-2 T IE3		75,5	70,5	68	66,5	62,5	59,5	56	48,5	38,5	28,5
NKV 95/3 T IE3		93,5	84	80,5	78	74	72	69	62,5	53,5	44
NKV 95/4-2 T IE3		108	100	97	94,5	89	85,5	81	71,5	59	46
NKV 95/4 T IE3		125,5	112,5	108	105	99,5	96,5	92,5	84	72	60
NKV 95/5-2 T IE3		139	127,5	123,5	120	113,5	109	103,5	92	76	60
NKV 95/5 T IE3		156	140	134,5	130,5	123,5	120	114,5	104,5	89	74
NKV 95/6-2 T IE3		170,5	156	150,5	146,5	138,5	134	127	113,5	94,5	75,5
NKV 95/6 T IE3		188	169	161,5	157	149	144,5	138,5	126	108	89,5

# NKV 1 - MULTISTAGE CENTRIFUGAL ELECTRIC PUMPS WITH VERTICAL AXIS, FOR CIVIL AND INDUSTRIAL PRESSURIZATION UNITS

Liquid temperature range: from - 30°C to +120°C - Maximum working pressure: 25 bar (2500 kPa)

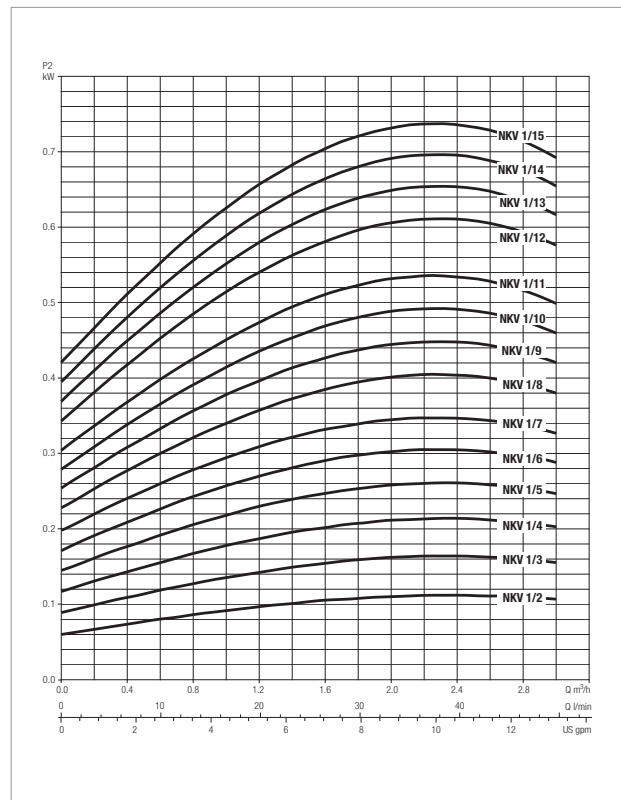
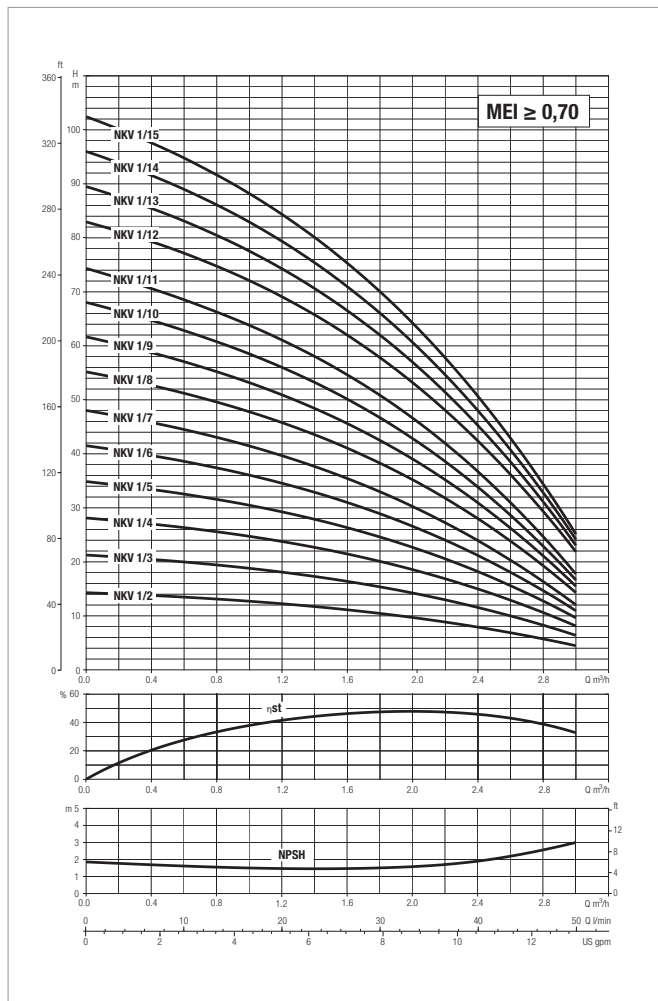

For hydraulic efficiency see pag. 35  
The performance curves are based on kinematic viscosity values = 1 mm<sup>2</sup>/s and density equivalent to 1000 kg/m<sup>3</sup>. Tolerance of curves to ISO 9906.

MODEL	VOLTAGE 50 Hz	P2 NOMINAL		In A	Ist A	Motor Frame	MEC Motor	1/min	η max Motor %	cos φ
		kW	HP							
NKV 1/2 T IE3	3 x 220-240Δ /380-415Y	0,37	0,50	1,7/1,0	8,5-9,2/4,9-5,3	B14	71	2800	78,5	0,80-0,70
NKV 1/3 T IE3	3 x 220-240Δ /380-415Y	0,37	0,50	1,7/1,0	8,5-9,2/4,9-5,3	B14	71	2800	78,5	0,80-0,70
NKV 1/4 T IE3	3 x 220-240Δ /380-415Y	0,37	0,50	1,7/1,0	8,5-9,2/4,9-5,3	B14	71	2800	78,5	0,80-0,70
NKV 1/5 T IE3	3 x 220-240Δ /380-415Y	0,37	0,50	1,7/1,0	8,5-9,2/4,9-5,3	B14	71	2800	78,5	0,80-0,70
NKV 1/6 T IE3	3 x 220-240Δ /380-415Y	0,37	0,50	1,7/1,0	8,5-9,2/4,9-5,3	B14	71	2800	78,5	0,80-0,70
NKV 1/7 T IE3	3 x 220-240Δ /380-415Y	0,37	0,50	1,7/1,0	8,5-9,2/4,9-5,3	B14	71	2800	78,5	0,80-0,70
NKV 1/8 T IE3	3 x 220-240Δ /380-415Y	0,55	0,75	2,7/1,6	12-13/6,9-7,5	B14	71	2830	80	0,80-0,70
NKV 1/9 T IE3	3 x 220-240Δ /380-415Y	0,55	0,75	2,7/1,6	12-13/6,9-7,5	B14	71	2830	80	0,80-0,70
NKV 1/10 T IE3	3 x 220-240Δ /380-415Y	0,55	0,75	2,7/1,6	12-13/6,9-7,5	B14	71	2830	80	0,80-0,70
NKV 1/11 T IE3	3 x 220-240Δ /380-415Y	0,55	0,75	2,7/1,6	12-13/6,9-7,5	B14	71	2830	80	0,80-0,70
NKV 1/12 T IE3	3 x 220-240Δ /380-415Y	0,75	1,00	3,9/1,7	19,1-20,5/11,0-11,8	B14	80S	2910	81	0,81-0,71
NKV 1/13 T IE3	3 x 220-240Δ /380-415Y	0,75	1,00	3,9/1,7	19,1-20,5/11,0-11,8	B14	80S	2910	81	0,81-0,71
NKV 1/14 T IE3	3 x 220-240Δ /380-415Y	0,75	1,00	3,9/1,7	19,1-20,5/11,0-11,8	B14	80S	2910	81	0,81-0,71
NKV 1/15 T IE3	3 x 220-240Δ /380-415Y	0,75	1,00	3,9/1,7	19,1-20,5/11,0-11,8	B14	80S	2910	81	0,81-0,71

# NKV 1 - MULTISTAGE CENTRIFUGAL ELECTRIC PUMPS WITH VERTICAL AXIS, FOR CIVIL AND INDUSTRIAL PRESSURIZATION UNITS

Liquid temperature range: from - 30°C to +120°C - Maximum working pressure: 25 bar (2500 kPa)

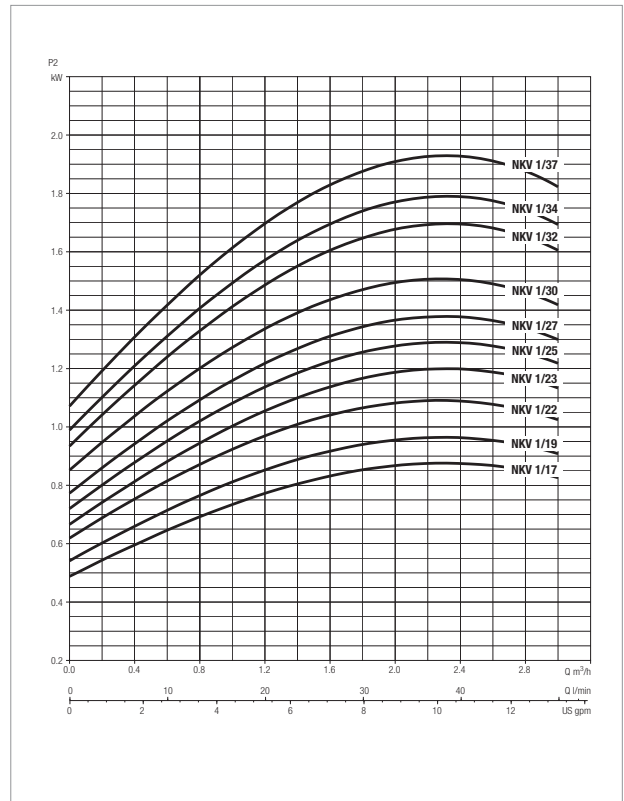
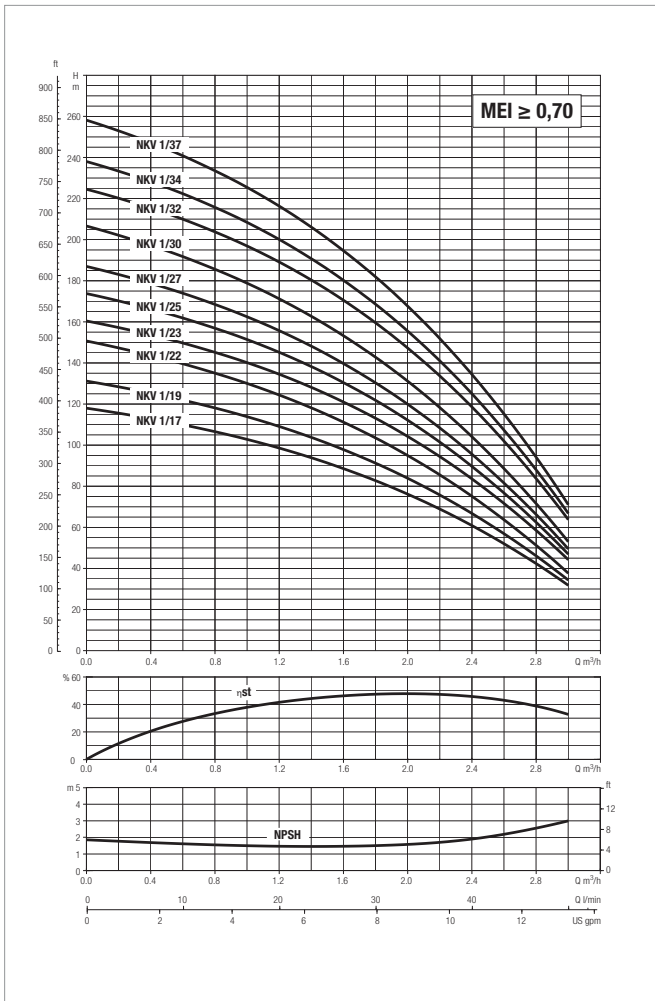

For hydraulic efficiency see pag. 35  
The performance curves are based on kinematic viscosity values = 1 mm²/s and density equivalent to 1000 kg/m³. Tolerance of curves to ISO 9906.

MODEL	VOLTAGE 50 Hz	P2 NOMINAL		In A	Ist A	Motor Frame	MEC Motor	1/min	$\eta$ max Motor %	cos $\phi$
		kW	HP							
NKV 1/17 T IE3	3 x 220-240Δ /380-415Y	1,10	1,50	4,1/2,4	28,5-31,5/16,3/17,9	B14	80M	2870	82,7	0,84-0,76
NKV 1/19 T IE3	3 x 220-240Δ /380-415Y	1,10	1,50	4,1/2,4	28,5-31,5/16,3/17,9	B14	80M	2870	82,7	0,84-0,76
NKV 1/22 T IE3	3 x 220-240Δ /380-415Y	1,10	1,50	4,1/2,4	28,5-31,5/16,3/17,9	B14	80M	2870	82,7	0,84-0,76
NKV 1/23 T IE3	3 x 220-240Δ /380-415Y	1,50	2,00	5,1/3,0	46,3-50,7/26,8-29,3	B14	90S	2875	84,2	0,85-0,75
NKV 1/25 T IE3	3 x 220-240Δ /380-415Y	1,50	2,00	5,1/3,0	46,3-50,7/26,8-29,3	B14	90S	2875	84,2	0,85-0,75
NKV 1/27 T IE3	3 x 220-240Δ /380-415Y	1,50	2,00	5,1/3,0	46,3-50,7/26,8-29,3	B14	90S	2875	84,2	0,85-0,75
NKV 1/30 T IE3	3 x 220-240Δ /380-415Y	1,50	2,00	5,1/3,0	46,3-50,7/26,8-29,3	B14	90S	2875	84,2	0,85-0,75
NKV 1/32 T IE3	3 x 220-240Δ /380-415Y	2,20	3,00	7,8-4,6	37,8-42,3	B14	90L	2880	86,5	0,87-0,80
NKV 1/34 T IE3	3 x 220-240Δ /380-415Y	2,20	3,00	7,8-4,6	37,8-42,3	B14	90L	2880	86,5	0,87-0,80
NKV 1/37 T IE3	3 x 220-240Δ /380-415Y	2,20	3,00	7,8-4,6	37,8-42,3	B14	90L	2880	86,5	0,87-0,80

# NKV 1 - MULTISTAGE CENTRIFUGAL ELECTRIC PUMPS WITH VERTICAL AXIS, FOR CIVIL AND INDUSTRIAL PRESSURIZATION UNITS

Liquid temperature range: from - 30°C to +120°C - Maximum working pressure: 25 bar (2500 kPa)

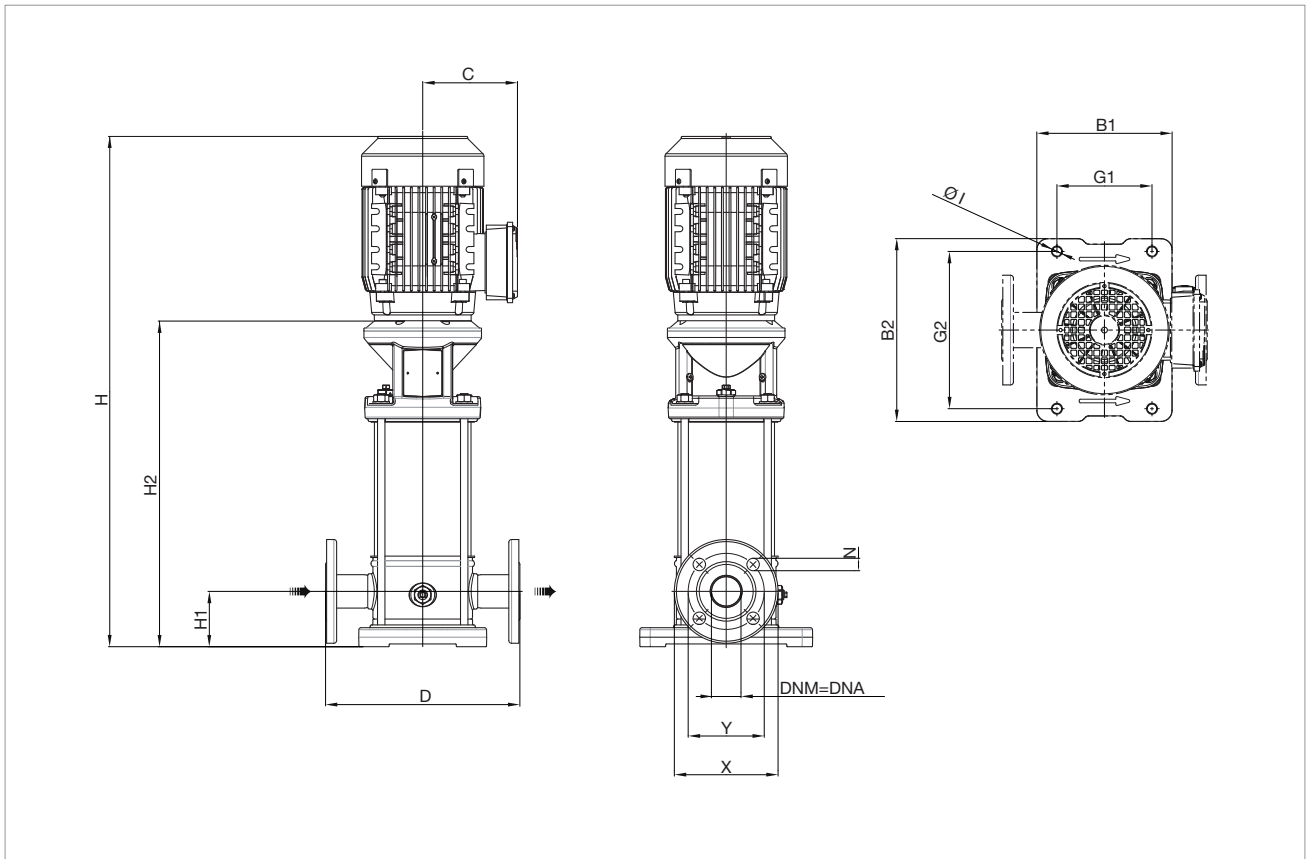

Version F: The pump is supplied without counter flanges (optional accessories, including joints and bolts).

MODEL	STAGE N°	B1	B2	G1	G2	Ø I	C	D	H	H1	H2	DNA = DNM (DN 25)			PACKING DIMENSIONS			VOL. mc	WEIGHT Kg
												X	Y	N	L/A	L/B	H		
NKV 1/2 T IE3	2	150	210	100	180	13	110	250	529	75	313	115	85	14	655	272	275	0,049	17,3
NKV 1/3 T IE3	3	150	210	100	180	13	110	250	552	75	336	115	85	14	655	272	275	0,049	17,8
NKV 1/4 T IE3	4	150	210	100	180	13	110	250	574	75	358	115	85	14	655	272	275	0,049	18,3
NKV 1/5 T IE3	5	150	210	100	180	13	110	250	597	75	381	115	85	14	655	272	275	0,049	18,8
NKV 1/6 T IE3	6	150	210	100	180	13	110	250	619	75	403	115	85	14	655	272	275	0,049	19,3
NKV 1/7 T IE3	7	150	210	100	180	13	110	250	642	75	426	115	85	14	655	272	275	0,049	19,8
NKV 1/8 T IE3	8	150	210	100	180	13	110	250	664	75	448	115	85	14	905	272	275	0,068	20,7
NKV 1/9 T IE3	9	150	210	100	180	13	110	250	687	75	471	115	85	14	905	272	275	0,068	21,2
NKV 1/10 T IE3	10	150	210	100	180	13	110	250	709	75	493	115	85	14	905	272	275	0,068	21,7
NKV 1/11 T IE3	11	150	210	100	180	13	110	250	732	75	516	115	85	14	905	272	275	0,068	22,2
NKV 1/12 T IE3	12	150	210	100	180	13	129	250	770	75	538	115	85	14	905	272	275	0,068	26,0
NKV 1/13 T IE3	13	150	210	100	180	13	129	250	793	75	561	115	85	14	905	272	275	0,068	26,5
NKV 1/14 T IE3	14	150	210	100	180	13	129	250	815	75	583	115	85	14	905	272	275	0,068	26,5
NKV 1/15 T IE3	15	150	210	100	180	13	129	250	838	75	606	115	85	14	905	272	275	0,068	27,0
NKV 1/17 T IE3	17	150	210	100	180	13	129	250	883	75	651	115	85	14	950	290	440	0,121	29,6
NKV 1/19 T IE3	19	150	210	100	180	13	129	250	928	75	696	115	85	14	1220	280	430	0,147	30,6
NKV 1/22 T IE3	22	150	210	100	180	13	129	250	995	75	763	115	85	14	1220	280	430	0,147	32,1
NKV 1/23 T IE3	23	150	210	100	180	13	138	250	1063	75	796	115	85	14	1220	280	430	0,147	36,0
NKV 1/25 T IE3	25	150	210	100	180	13	138	250	1108	75	841	115	85	14	1220	280	430	0,147	37,0
NKV 1/27 T IE3	27	150	210	100	180	13	138	250	1153	75	886	115	85	14	1220	280	430	0,147	38,0
NKV 1/30 T IE3	30	150	210	100	180	13	138	250	1220	75	953	115	85	14	1610	340	480	0,263	39,0
NKV 1/32 T IE3	32	150	210	100	180	13	138	250	1265	75	998	115	85	14	1610	340	480	0,263	42,0
NKV 1/34 T IE3	34	150	210	100	180	13	138	250	1310	75	1043	115	85	14	1610	340	480	0,263	43,0
NKV 1/37 T IE3	37	150	210	100	180	13	138	250	1378	75	1111	115	85	14	1610	340	480	0,263	44,5

# NKV 3 - MULTISTAGE CENTRIFUGAL ELECTRIC PUMPS WITH VERTICAL AXIS, FOR CIVIL AND INDUSTRIAL PRESSURIZATION UNITS

Liquid temperature range: from - 30°C to +120°C - Maximum working pressure: 25 bar (2500 kPa)

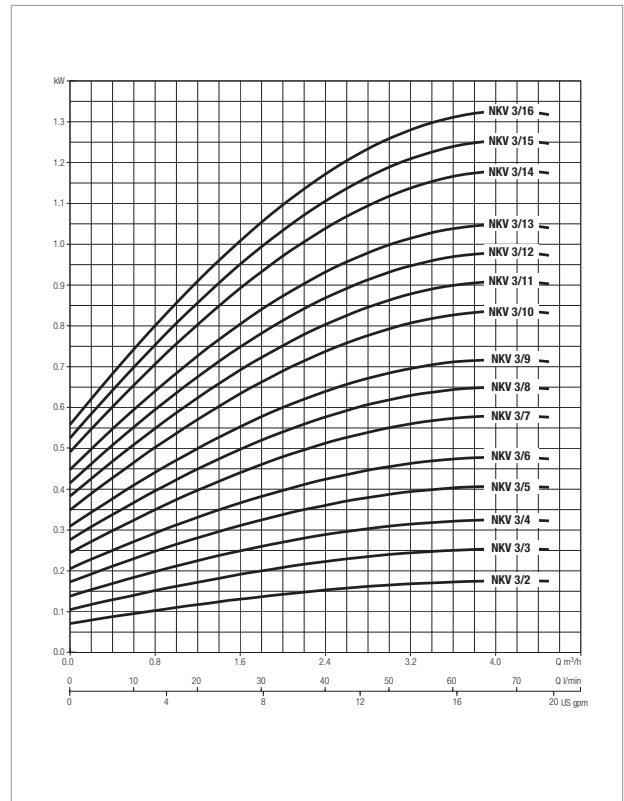
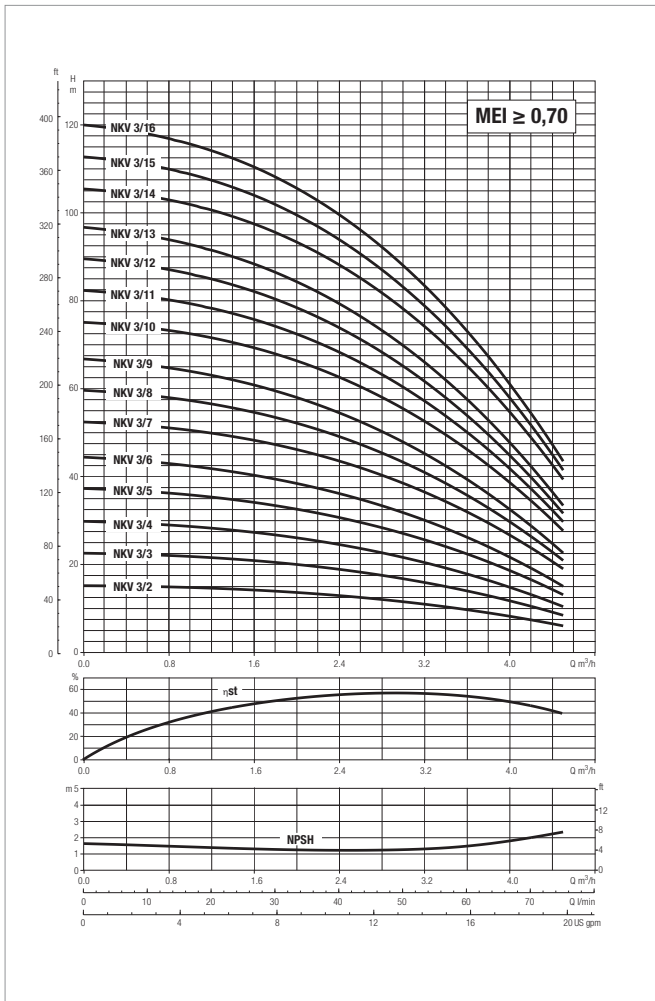

For hydraulic efficiency see pag. 35  
The performance curves are based on kinematic viscosity values = 1 mm<sup>2</sup>/s and density equivalent to 1000 kg/m<sup>3</sup>. Tolerance of curves to ISO 9906.

MODEL	VOLTAGE 50 Hz	P2 NOMINAL		In A	Ist A	Motor Frame	MEC Motor	1/min	η max Motor %	cos φ
		kW	HP							
NKV 3/2 T IE3	3 x 220-240Δ /380-415Y	0,37	0,50	1,7/1,0	8,5-9,2/4,9-5,3	B14	71	2800	78,5	0,80-0,70
NKV 3/3 T IE3	3 x 220-240Δ /380-415Y	0,37	0,50	1,7/1,0	8,5-9,2/4,9-5,3	B14	71	2800	78,5	0,80-0,70
NKV 3/4 T IE3	3 x 220-240Δ /380-415Y	0,37	0,50	1,7/1,0	8,5-9,2/4,9-5,3	B14	71	2800	78,5	0,80-0,70
NKV 3/5 T IE3	3 x 220-240Δ /380-415Y	0,55	0,75	2,7/1,6	12-13/6,9-7,5	B14	71	2830	80	0,80-0,70
NKV 3/6 T IE3	3 x 220-240Δ /380-415Y	0,55	0,75	2,7/1,6	12-13/6,9-7,5	B14	71	2830	80	0,80-0,70
NKV 3/7 T IE3	3 x 220-240Δ /380-415Y	0,75	1,00	3,9/1,7	19,1-20,5/11,0-11,8	B14	80S	2910	81	0,81-0,71
NKV 3/8 T IE3	3 x 220-240Δ /380-415Y	0,75	1,00	3,9/1,7	19,1-20,5/11,0-11,8	B14	80S	2910	81	0,81-0,71
NKV 3/9 T IE3	3 x 220-240Δ /380-415Y	0,75	1,00	3,9/1,7	19,1-20,5/11,0-11,8	B14	80S	2910	81	0,81-0,71
NKV 3/10 T IE3	3 x 220-240Δ /380-415Y	1,10	1,50	4,1/2,4	28,5-31,5/16,3/17,9	B14	80M	2870	82,7	0,84-0,76
NKV 3/11 T IE3	3 x 220-240Δ /380-415Y	1,10	1,50	4,1/2,4	28,5-31,5/16,3/17,9	B14	80M	2870	82,7	0,84-0,76
NKV 3/12 T IE3	3 x 220-240Δ /380-415Y	1,10	1,50	4,1/2,4	28,5-31,5/16,3/17,9	B14	80M	2870	82,7	0,84-0,76
NKV 3/13 T IE3	3 x 220-240Δ /380-415Y	1,10	1,50	4,1/2,4	28,5-31,5/16,3/17,9	B14	80M	2870	82,7	0,84-0,76
NKV 3/14 T IE3	3 x 220-240Δ /380-415Y	1,50	2,00	5,1/3,0	46,3-50,7/26,8-29,3	B14	90S	2875	84,2	0,85-0,75
NKV 3/15 T IE3	3 x 220-240Δ /380-415Y	1,50	2,00	5,1/3,0	46,3-50,7/26,8-29,3	B14	90S	2875	84,2	0,85-0,75
NKV 3/16 T IE3	3 x 220-240Δ /380-415Y	1,50	2,00	5,1/3,0	46,3-50,7/26,8-29,3	B14	90S	2875	84,2	0,85-0,75

# NKV 3 - MULTISTAGE CENTRIFUGAL ELECTRIC PUMPS WITH VERTICAL AXIS, FOR CIVIL AND INDUSTRIAL PRESSURIZATION UNITS

Liquid temperature range: from - 30°C to +120°C - Maximum working pressure: 25 bar (2500 kPa)

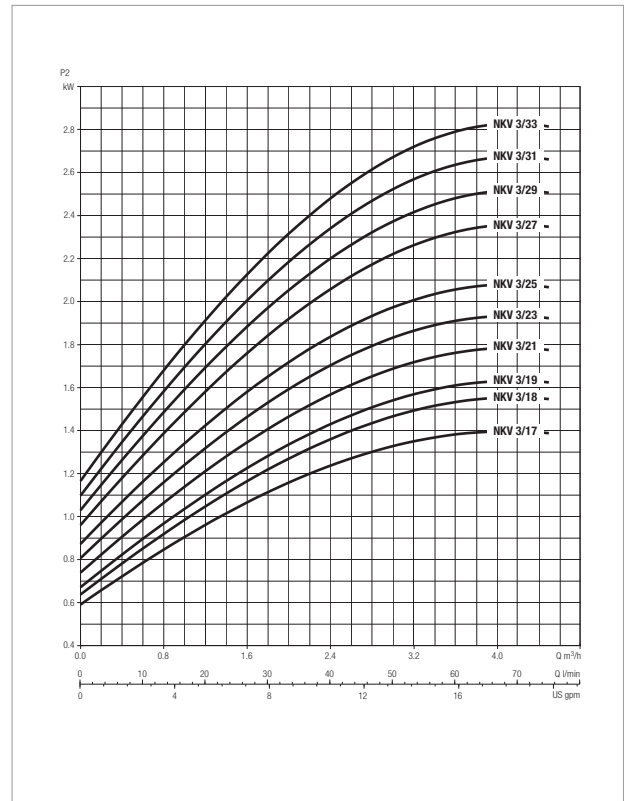
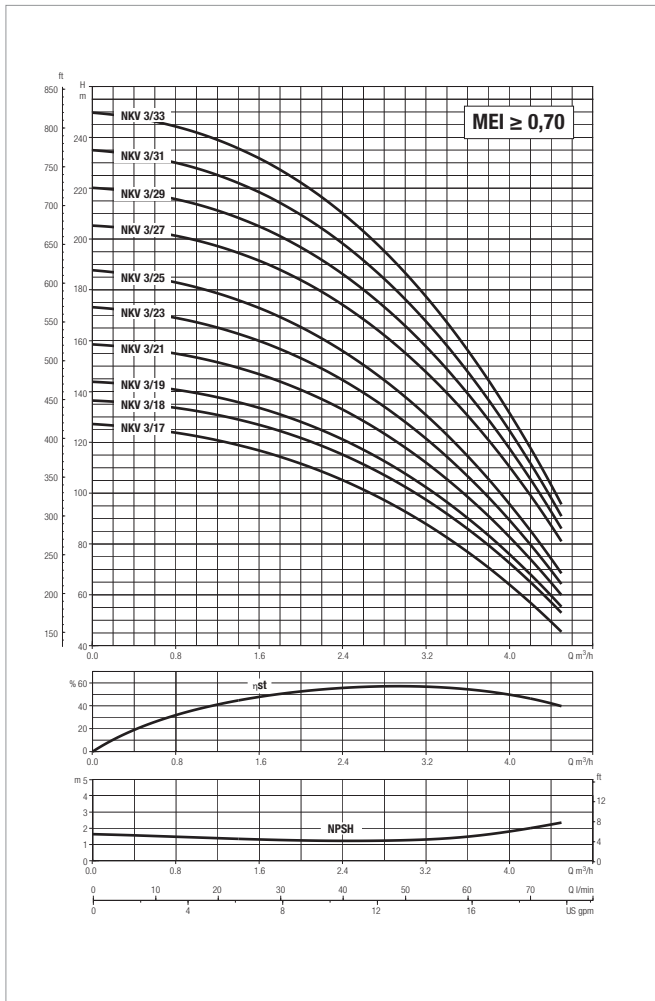

For hydraulic efficiency see pag. 35  
The performance curves are based on kinematic viscosity values = 1 mm²/s and density equivalent to 1000 kg/m³. Tolerance of curves to ISO 9906.

MODEL	VOLTAGE 50 Hz	P2 NOMINAL		In A	Ist A	Motor Frame	MEC Motor	1/min	η max Motor %	cos φ
		kW	HP							
NKV 3/17 T IE3	3 x 220-240Δ /380-415Y	1,50	2,00	5,1/3,0	46,3-50,7/26,8-29,3	B14	90S	2875	84,2	0,85-0,75
NKV 3/18 T IE3	3 x 220-240Δ /380-415Y	2,20	3,00	7,8-4,6	37,8-42,3	B14	90L	2880	86,5	0,87-0,80
NKV 3/19 T IE3	3 x 220-240Δ /380-415Y	2,20	3,00	7,8-4,6	37,8-42,3	B14	90L	2880	86,5	0,87-0,80
NKV 3/21 T IE3	3 x 220-240Δ /380-415Y	2,20	3,00	7,8-4,6	37,8-42,3	B14	90L	2880	86,5	0,87-0,80
NKV 3/23 T IE3	3 x 220-240Δ /380-415Y	2,20	3,00	7,8-4,6	37,8-42,3	B14	90L	2880	86,5	0,87-0,80
NKV 3/25 T IE3	3 x 220-240Δ /380-415Y	2,20	3,00	7,8-4,6	37,8-42,3	B14	90L	2880	86,5	0,87-0,80
NKV 3/27 T IE3	3 x 380-415Δ	3,00	4,00	5,6	52,9-58	B14	100L	2900	87,1	0,89
NKV 3/29 T IE3	3 x 380-415Δ	3,00	4,00	5,6	52,9-58	B14	100L	2900	87,1	0,89
NKV 3/31 T IE3	3 x 380-415Δ	3,00	4,00	5,6	52,9-58	B14	100L	2900	87,1	0,89
NKV 3/33 T IE3	3 x 380-415Δ	3,00	4,00	5,6	52,9-58	B14	100L	2900	87,1	0,89

# NKV 3 - MULTISTAGE CENTRIFUGAL ELECTRIC PUMPS WITH VERTICAL AXIS, FOR CIVIL AND INDUSTRIAL PRESSURIZATION UNITS

Liquid temperature range: from - 30°C to +120°C - Maximum working pressure: 25 bar (2500 kPa)

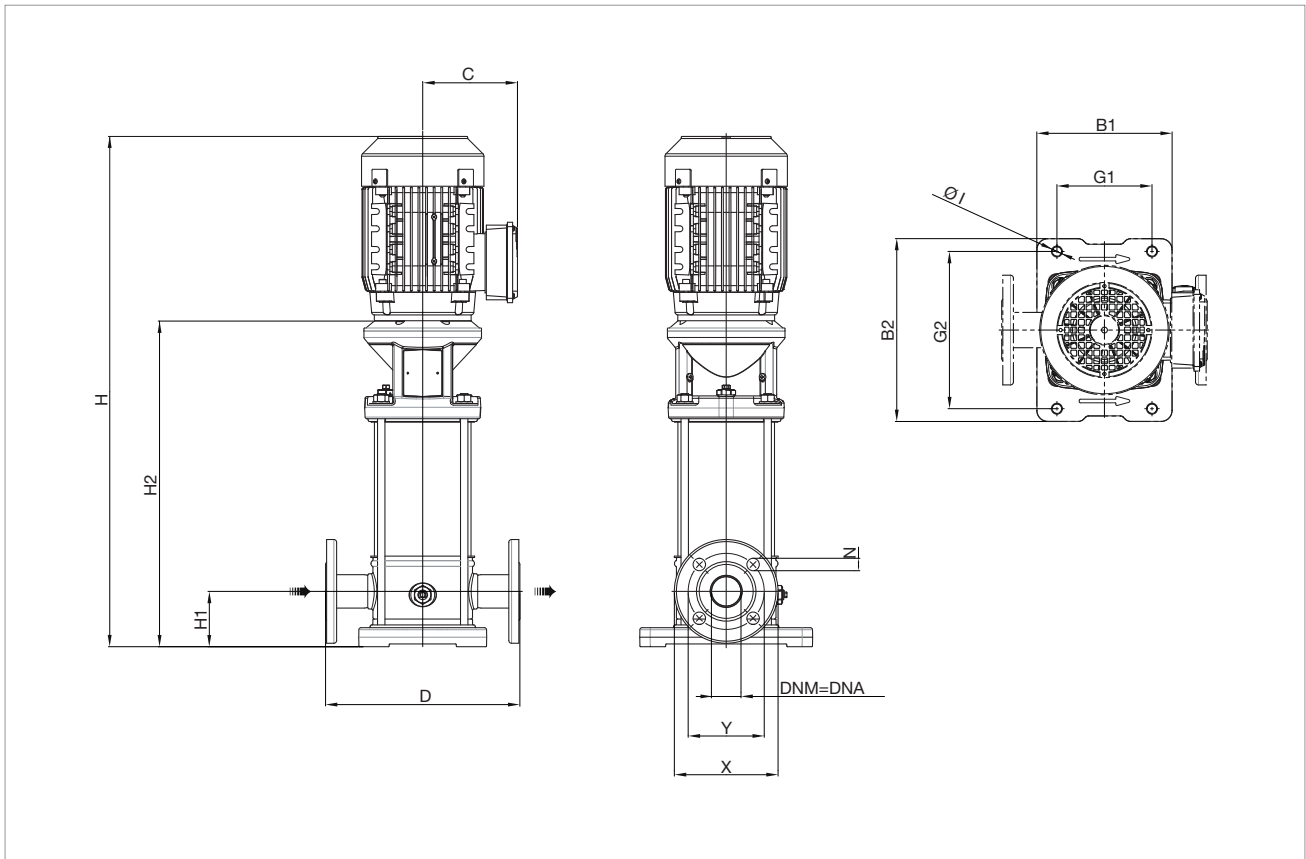

Version F: The pump is supplied without counter flanges (optional accessories, including joints and bolts).

MODEL	STAGE N°	B1	B2	G1	G2	Ø1	C	D	H	H1	H2	DNA = DNM (DN 25)			PACKING DIMENSIONS			VOL. mc	WEIGHT Kg
												X	Y	N	L/A	L/B	H		
NKV 3/2 T IE3	2	150	210	100	180	13	110	250	529	75	313	115	85	14	655	272	275	0,049	17,3
NKV 3/3 T IE3	3	150	210	100	180	13	110	250	552	75	336	115	85	14	655	272	275	0,049	17,8
NKV 3/4 T IE3	4	150	210	100	180	13	110	250	574	75	358	115	85	14	655	272	275	0,049	18,3
NKV 3/5 T IE3	5	150	210	100	180	13	110	250	597	75	381	115	85	14	655	272	275	0,049	19,2
NKV 3/6 T IE3	6	150	210	100	180	13	110	250	619	75	403	115	85	14	655	272	275	0,049	19,7
NKV 3/7 T IE3	7	150	210	100	180	13	129	250	658	75	426	115	85	14	905	272	275	0,068	23,5
NKV 3/8 T IE3	8	150	210	100	180	13	129	250	680	75	448	115	85	14	905	272	275	0,068	24,0
NKV 3/9 T IE3	9	150	210	100	180	13	129	250	703	75	471	115	85	14	905	272	275	0,068	24,5
NKV 3/10 T IE3	10	150	210	100	180	13	129	250	725	75	493	115	85	14	905	272	275	0,068	26,6
NKV 3/11 T IE3	11	150	210	100	180	13	129	250	748	75	516	115	85	14	905	272	275	0,068	27,1
NKV 3/12 T IE3	12	150	210	100	180	13	129	250	770	75	538	115	85	14	905	272	275	0,068	27,6
NKV 3/13 T IE3	13	150	210	100	180	13	129	250	793	75	561	115	85	14	905	272	275	0,068	28,1
NKV 3/14 T IE3	14	150	210	100	180	13	138	250	860	75	593	115	85	14	950	290	440	0,121	32,0
NKV 3/15 T IE3	15	150	210	100	180	13	138	250	883	75	616	115	85	14	950	290	440	0,121	32,5
NKV 3/16 T IE3	16	150	210	100	180	13	138	250	905	75	638	115	85	14	1220	280	430	0,147	32,5
NKV 3/17 T IE3	17	150	210	100	180	13	138	250	928	75	661	115	85	14	1220	280	430	0,147	33,0
NKV 3/18 T IE3	18	150	210	100	180	13	138	250	950	75	683	115	85	14	1220	280	430	0,147	35,5
NKV 3/19 T IE3	19	150	210	100	180	13	138	250	973	75	706	115	85	14	1220	280	430	0,147	36,0
NKV 3/21 T IE3	21	150	210	100	180	13	138	250	1018	75	751	115	85	14	1220	280	430	0,147	37,0
NKV 3/23 T IE3	23	150	210	100	180	13	138	250	1063	75	796	115	85	14	1220	280	430	0,147	38,0
NKV 3/25 T IE3	25	150	210	100	180	13	138	250	1108	75	841	115	85	14	1220	280	430	0,147	39,0
NKV 3/27 T IE3	27	150	210	100	180	13	145	250	1202	75	896	115	85	14	1610	340	480	0,263	47,3
NKV 3/29 T IE3	29	150	210	100	180	13	145	250	1247	75	941	115	85	14	1610	340	480	0,263	48,3
NKV 3/31 T IE3	31	150	210	100	180	13	145	250	1292	75	986	115	85	14	1610	340	480	0,263	49,3
NKV 3/33 T IE3	33	150	210	100	180	13	145	250	1337	75	1031	115	85	14	1610	340	480	0,263	50,3

# NKV 6 - MULTISTAGE CENTRIFUGAL ELECTRIC PUMPS WITH VERTICAL AXIS, FOR CIVIL AND INDUSTRIAL PRESSURIZATION UNITS

Liquid temperature range: from - 30°C to +120°C - Maximum working pressure: 25 bar (2500 kPa)

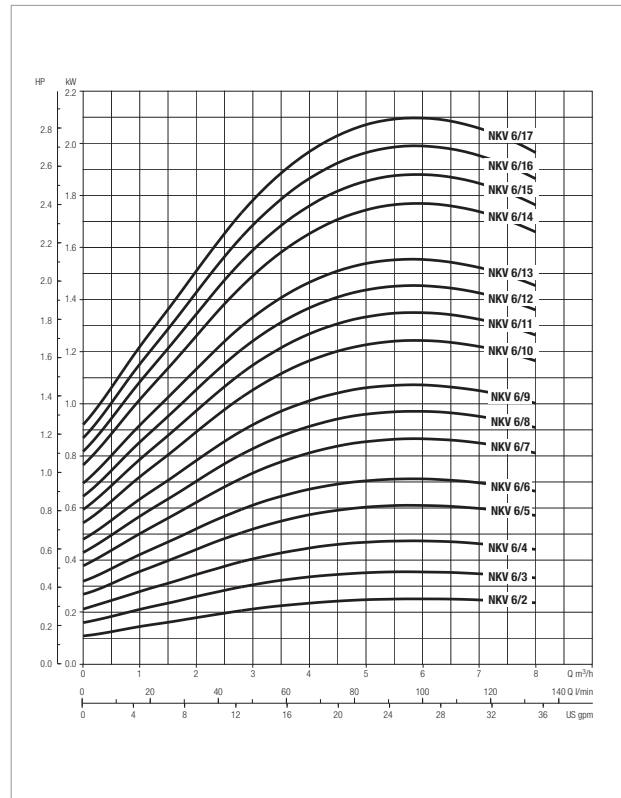
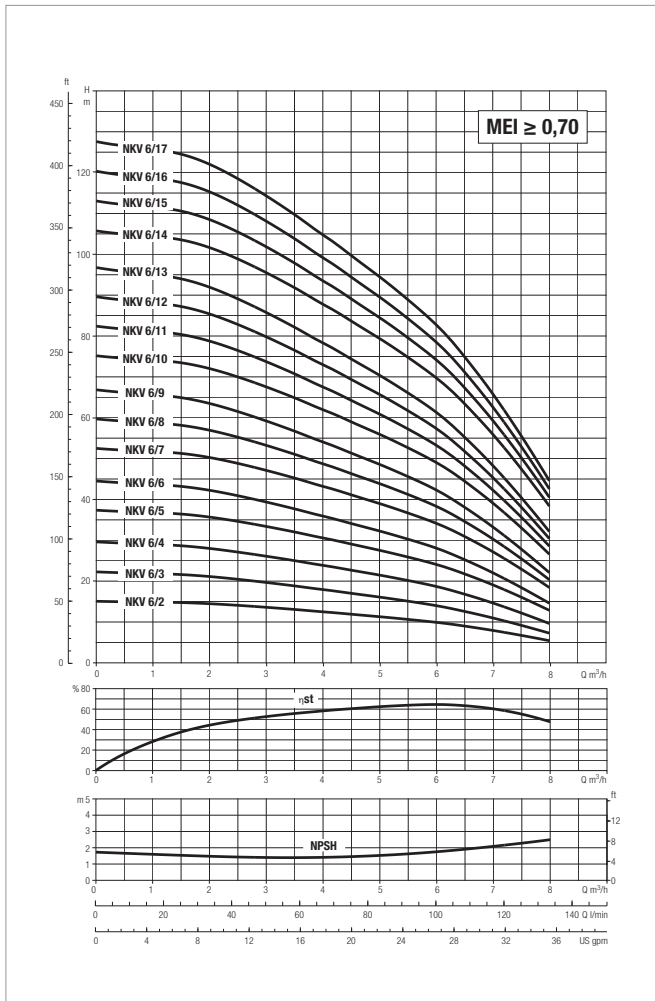

**For hydraulic efficiency see pag. 35**  
The performance curves are based on kinematic viscosity values = 1 mm<sup>2</sup>/s and density equivalent to 1000 kg/m<sup>3</sup>. Tolerance of curves to ISO 9906.

MODEL	VOLTAGE 50 Hz	P2 NOMINAL		In A	Ist A	Motor Frame	MEC Motor	1/min	η max Motor %	cos φ
		kW	HP							
NKV 6/2 T IE3	3 x 220-240Δ /380-415Y	0,37	0,50	1,7/1,0	8,5-9,2/4,9-5,3	B14	71	2800	78,5	0,80-0,70
NKV 6/3 T IE3	3 x 220-240Δ /380-415Y	0,37	0,50	1,7/1,0	8,5-9,2/4,9-5,3	B14	71	2800	78,5	0,80-0,70
NKV 6/4 T IE3	3 x 220-240Δ /380-415Y	0,55	0,75	2,7/1,6	12-13/6,9-7,5	B14	71	2830	80	0,80-0,70
NKV 6/5 T IE3	3 x 220-240Δ /380-415Y	0,75	1,00	3,9/1,7	19,1-20,5/11,0-11,8	B14	80S	2910	81	0,81-0,71
NKV 6/6 T IE3	3 x 220-240Δ /380-415Y	0,75	1,00	3,9/1,7	19,1-20,5/11,0-11,8	B14	80S	2910	81	0,81-0,71
NKV 6/7 T IE3	3 x 220-240Δ /380-415Y	1,10	1,50	4,1/2,4	28,5-31,5/16,3/17,9	B14	80M	2870	82,7	0,84-0,76
NKV 6/8 T IE3	3 x 220-240Δ /380-415Y	1,10	1,50	4,1/2,4	28,5-31,5/16,3/17,9	B14	80M	2870	82,7	0,84-0,76
NKV 6/9 T IE3	3 x 220-240Δ /380-415Y	1,10	1,50	4,1/2,4	28,5-31,5/16,3/17,9	B14	80M	2870	82,7	0,84-0,76
NKV 6/10 T IE3	3 x 220-240Δ /380-415Y	1,50	2,00	5,1/3,0	46,3-50,7/26,8-29,3	B14	90S	2875	84,2	0,85-0,75
NKV 6/11 T IE3	3 x 220-240Δ /380-415Y	1,50	2,00	5,1/3,0	46,3-50,7/26,8-29,3	B14	90S	2875	84,2	0,85-0,75
NKV 6/12 T IE3	3 x 220-240Δ /380-415Y	1,50	2,00	5,1/3,0	46,3-50,7/26,8-29,3	B14	90S	2875	84,2	0,85-0,75
NKV 6/13 T IE3	3 x 220-240Δ /380-415Y	1,50	2,00	5,1/3,0	46,3-50,7/26,8-29,3	B14	90S	2875	84,2	0,85-0,75
NKV 6/14 T IE3	3 x 220-240Δ /380-415Y	2,20	3,00	7,8-4,6	37,8-42,3	B14	90L	2880	86,5	0,87-0,80
NKV 6/15 T IE3	3 x 220-240Δ /380-415Y	2,20	3,00	7,8-4,6	37,8-42,3	B14	90L	2880	86,5	0,87-0,80
NKV 6/16 T IE3	3 x 220-240Δ /380-415Y	2,20	3,00	7,8-4,6	37,8-42,3	B14	90L	2880	86,5	0,87-0,80
NKV 6/17 T IE3	3 x 220-240Δ /380-415Y	2,20	3,00	7,8-4,6	37,8-42,3	B14	90L	2880	86,5	0,87-0,80

# NKV 6 - MULTISTAGE CENTRIFUGAL ELECTRIC PUMPS WITH VERTICAL AXIS, FOR CIVIL AND INDUSTRIAL PRESSURIZATION UNITSE

Liquid temperature range: from - 30°C to +120°C - Maximum working pressure: 25 bar (2500 kPa)

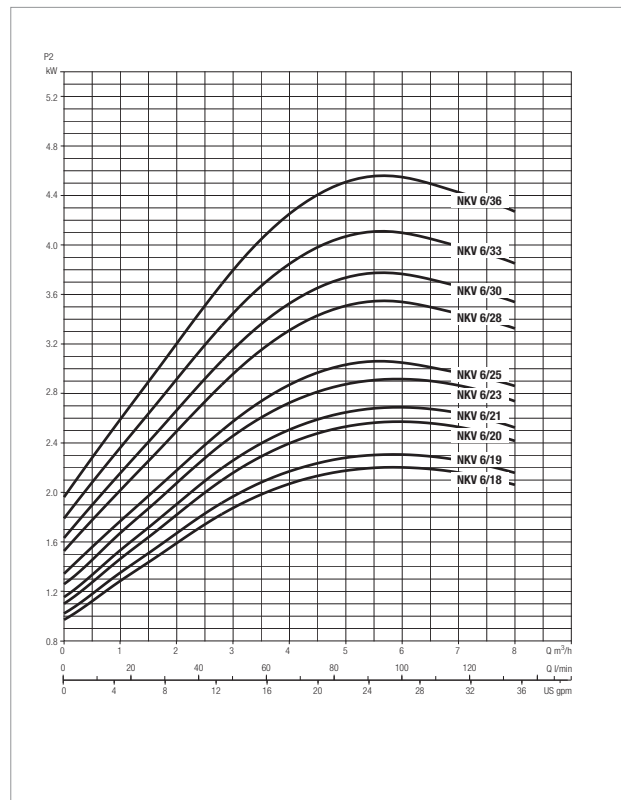
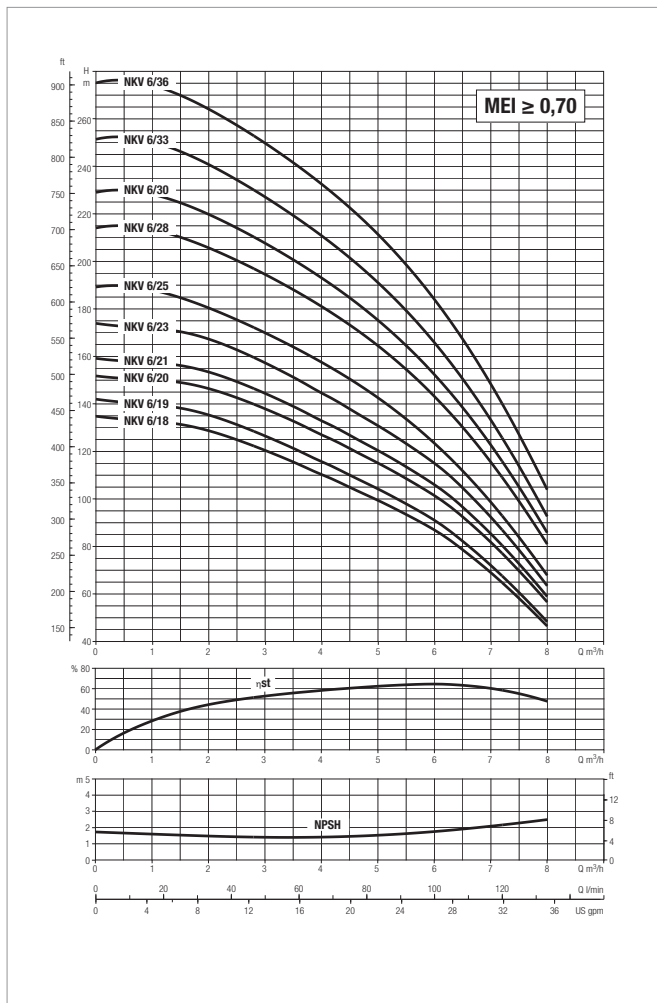

For hydraulic efficiency see pag. 35  
The performance curves are based on kinematic viscosity values = 1 mm<sup>2</sup>/s and density equivalent to 1000 kg/m<sup>3</sup>. Tolerance of curves to ISO 9906.

MODEL	VOLTAGE 50 Hz	P2 NOMINAL		In A	Ist A	Motor Frame	MEC Motor	1/min	η max Motor %	cos φ
		kW	HP							
NKV 6/18 T IE3	3 x 220-240Δ /380-415Y	2,20	3,00	7,8-4,6	37,8-42,3	B14	90L	2880	86,5	0,87-0,80
NKV 6/19 T IE3	3 x 220-240Δ /380-415Y	2,20	3,00	7,8-4,6	37,8-42,3	B14	90L	2880	86,5	0,87-0,80
NKV 6/20 T IE3	3 x 380-415Δ	3,00	4,00	5,6	52,9-58	B14	100L	2900	87,1	0,89
NKV 6/21 T IE3	3 x 380-415Δ	3,00	4,00	5,6	52,9-58	B14	100L	2900	87,1	0,89
NKV 6/23 T IE3	3 x 380-415Δ	3,00	4,00	5,6	52,9-58	B14	100L	2900	87,1	0,89
NKV 6/25 T IE3	3 x 380-415Δ	3,00	4,00	5,6	52,9-58	B14	100L	2900	87,1	0,89
NKV 6/28 T IE3	3 x 380-415Δ	4,00	5,50	8	89,6-98,4	B14	112M	2920	88,1	0,81
NKV 6/30 T IE3	3 x 380-415Δ	4,00	5,50	8	89,6-98,4	B14	112M	2920	88,1	0,81
NKV 6/33 T IE3	3 x 380-415Δ	4,00	5,50	8	89,6-98,4	B14	112M	2920	88,1	0,81
NKV 6/36 T IE3	3 x 380-415Δ	5,50	7,50	10,2	119,8-131	B5	132S	2935	89,2	0,87

# NKV 6 - MULTISTAGE CENTRIFUGAL ELECTRIC PUMPS WITH VERTICAL AXIS, FOR CIVIL AND INDUSTRIAL PRESSURIZATION UNITS

Liquid temperature range: from - 30°C to +120°C - Maximum working pressure: 25 bar (2500 kPa)

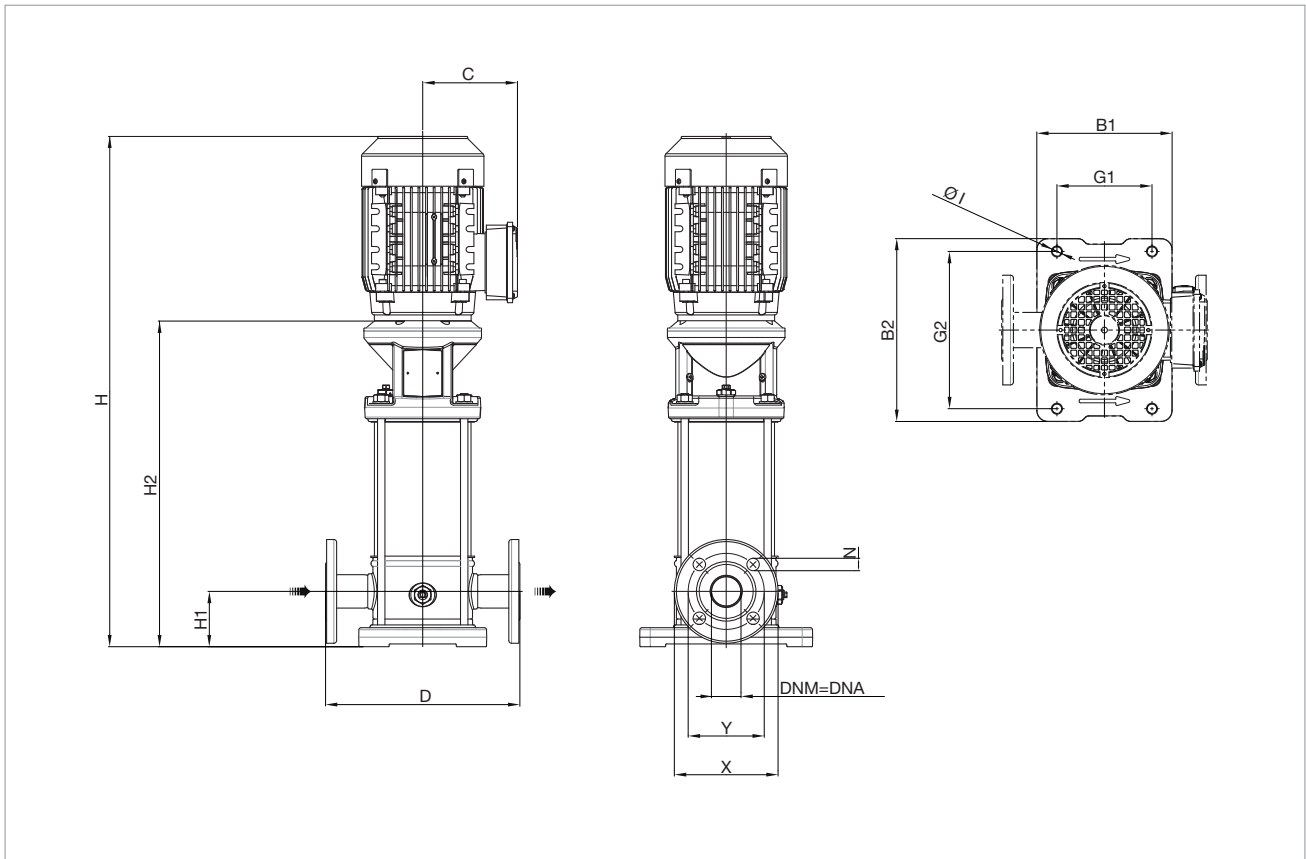

Version F: The pump is supplied without counter flanges (optional accessories, including joints and bolts).

MODEL	STAGE N°	B1	B2	G1	G2	Ø1	C	D	H	H1	H2	DNA = DNM (DN 32)			PACKING DIMENSIONS			VOL. mc	WEIGHT Kg
												X	Y	N	L/A	L/B	H		
NKV 6/2 T IE3	2	150	210	100	180	13	110	250	536	75	320	140	100	19	655	272	275	0,049	17,8
NKV 6/3 T IE3	3	150	210	100	180	13	110	250	562	75	346	140	100	19	655	272	275	0,049	18,3
NKV 6/4 T IE3	4	150	210	100	180	13	110	250	588	75	372	140	100	19	655	272	275	0,049	19,2
NKV 6/5 T IE3	5	150	210	100	180	13	129	250	630	75	398	140	100	19	655	272	275	0,049	23,0
NKV 6/6 T IE3	6	150	210	100	180	13	129	250	656	75	424	140	100	19	905	272	275	0,068	23,5
NKV 6/7 T IE3	7	150	210	100	180	13	129	250	682	75	450	140	100	19	905	272	275	0,068	25,6
NKV 6/8 T IE3	8	150	210	100	180	13	129	250	708	75	476	140	100	19	905	272	275	0,068	26,1
NKV 6/9 T IE3	9	150	210	100	180	13	129	250	734	75	502	140	100	19	905	272	275	0,068	26,6
NKV 6/10 T IE3	10	150	210	100	180	13	138	250	805	75	538	140	100	19	950	290	440	0,121	30,5
NKV 6/11 T IE3	11	150	210	100	180	13	138	250	831	75	564	140	100	19	950	290	440	0,121	31,5
NKV 6/12 T IE3	12	150	210	100	180	13	138	250	857	75	590	140	100	19	950	290	440	0,121	32,0
NKV 6/13 T IE3	13	150	210	100	180	13	138	250	883	75	616	140	100	19	950	290	440	0,121	32,5
NKV 6/14 T IE3	14	150	210	100	180	13	138	250	909	75	642	140	100	19	1220	280	430	0,147	35,0
NKV 6/15 T IE3	15	150	210	100	180	13	138	250	935	75	668	140	100	19	1220	280	430	0,147	35,5
NKV 6/16 T IE3	16	150	210	100	180	13	138	250	961	75	694	140	100	19	1220	280	430	0,147	36,0
NKV 6/17 T IE3	17	150	210	100	180	13	138	250	987	75	720	140	100	19	1220	280	430	0,147	36,5
NKV 6/18 T IE3	18	150	210	100	180	13	138	250	1013	75	746	140	100	19	1220	280	430	0,147	37,0
NKV 6/19 T IE3	19	150	210	100	180	13	138	250	1039	75	772	140	100	19	1220	280	430	0,147	37,5
NKV 6/20 T IE3	20	150	210	100	180	13	145	250	1114	75	808	140	100	19	1220	280	430	0,147	45,3
NKV 6/21 T IE3	21	150	210	100	180	13	145	250	1140	75	834	140	100	19	1220	280	430	0,147	45,8
NKV 6/23 T IE3	23	150	210	100	180	13	145	250	1192	75	886	140	100	19	1610	340	480	0,263	46,8
NKV 6/25 T IE3	25	150	210	100	180	13	145	250	1244	75	938	140	100	19	1610	340	480	0,263	47,8
NKV 6/28 T IE3	28	150	210	100	180	13	145	250	1322	75	1016	140	100	19	1610	340	480	0,263	53,0
NKV 6/30 T IE3	30	150	210	100	180	13	145	250	1374	75	1068	140	100	19	1610	340	480	0,263	54,5
NKV 6/33 T IE3	33	150	210	100	180	13	145	250	1452	75	1146	140	100	19	1610	340	480	0,263	56,0
NKV 6/36 T IE3	36	150	210	100	180	13	160	250	1728	75	1400	140	100	19	1820	500	630	0,573	84,1

# NKV 10 - MULTISTAGE CENTRIFUGAL ELECTRIC PUMPS WITH VERTICAL AXIS, FOR CIVIL AND INDUSTRIAL PRESSURIZATION UNITS

Liquid temperature range: from - 30°C to +120°C - Maximum working pressure: 25 bar (2500 kPa)

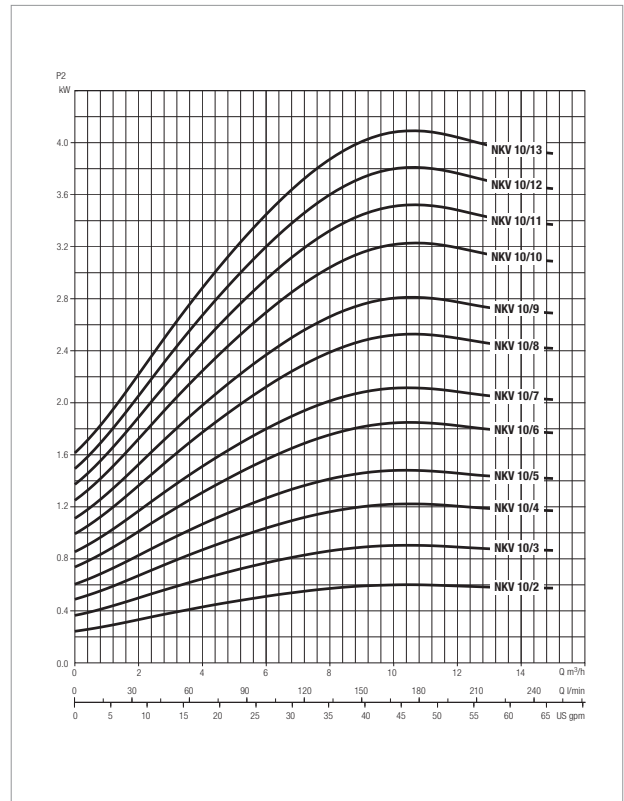
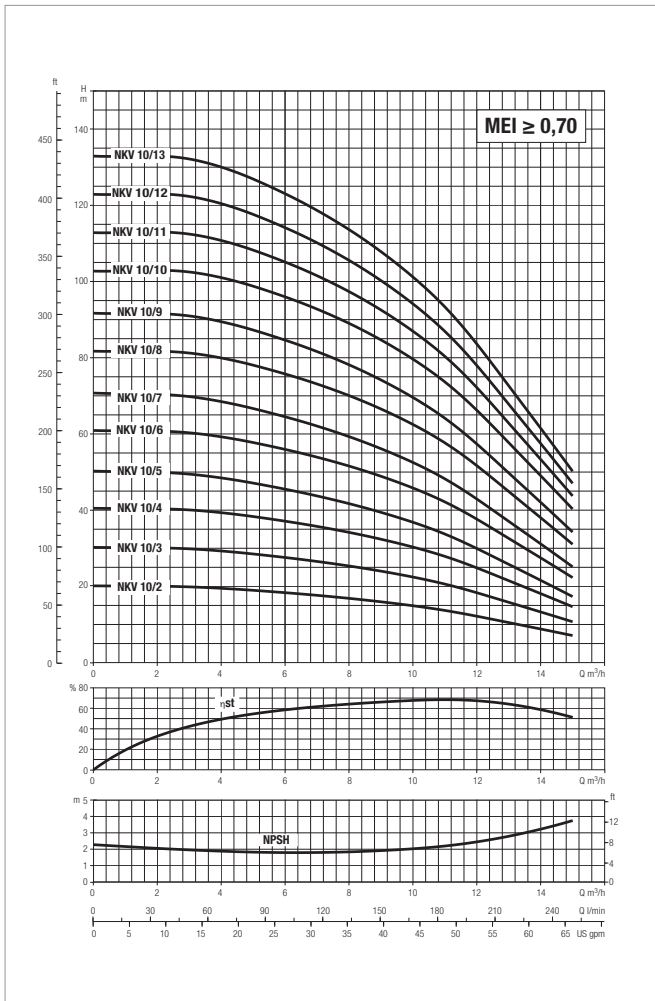

For hydraulic efficiency see pag. 35  
The performance curves are based on kinematic viscosity values = 1 mm²/s and density equivalent to 1000 kg/m³. Tolerance of curves to ISO 9906.

MODEL	VOLTAGE 50 Hz	P2 NOMINAL		In A	Ist A	Motor Frame	MEC Motor	1/min	$\eta$ max Motor %	cos $\phi$
		kW	HP							
NKV 10/2 T IE3	3 x 220-240Δ/380-415Y	0,75	1,00	3,9/1,7	19,1-20,5/11,0-11,8	B14	80S	2910	81	0,81-0,71
NKV 10/3 T IE3	3 x 220-240Δ/380-415Y	1,10	1,50	4,1/2,4	28,5-31,5/16,3/17,9	B14	80M	2870	82,7	0,84-0,76
NKV 10/4 T IE3	3 x 220-240Δ/380-415Y	1,50	2,00	5,1/3,0	46,3-50,7/26,8-29,3	B14	90S	2875	84,2	0,85-0,75
NKV 10/5 T IE3	3 x 220-240Δ/380-415Y	1,50	2,00	5,1/3,0	46,3-50,7/26,8-29,3	B14	90S	2875	84,2	0,85-0,75
NKV 10/6 T IE3	3 x 220-240Δ/380-415Y	2,20	3,00	7,8-4,6	37,8-42,3	B14	90L	2880	86,5	0,87-0,80
NKV 10/7 T IE3	3 x 220-240Δ/380-415Y	2,20	3,00	7,8-4,6	37,8-42,3	B14	90L	2880	86,5	0,87-0,80
NKV 10/8 T IE3	3 x 380-415Δ	3,00	4,00	5,6	52,9-58	B14	100L	2900	87,1	0,89
NKV 10/9 T IE3	3 x 380-415Δ	3,00	4,00	5,6	52,9-58	B14	100L	2900	87,1	0,89
NKV 10/10 T IE3	3 x 380-415Δ	4,00	5,50	8	89,6-98,4	B14	112M	2920	88,1	0,81
NKV 10/11 T IE3	3 x 380-415Δ	4,00	5,50	8	89,6-98,4	B14	112M	2920	88,1	0,81
NKV 10/12 T IE3	3 x 380-415Δ	4,00	5,50	8	89,6-98,4	B14	112M	2920	88,1	0,81
NKV 10/13 T IE3	3 x 380-415Δ	4,00	5,50	8	89,6-98,4	B14	112M	2920	88,1	0,81

# NKV 10 - MULTISTAGE CENTRIFUGAL ELECTRIC PUMPS WITH VERTICAL AXIS, FOR CIVIL AND INDUSTRIAL PRESSURIZATION UNITS

Liquid temperature range: from - 30°C to +120°C - Maximum working pressure: 25 bar (2500 kPa)

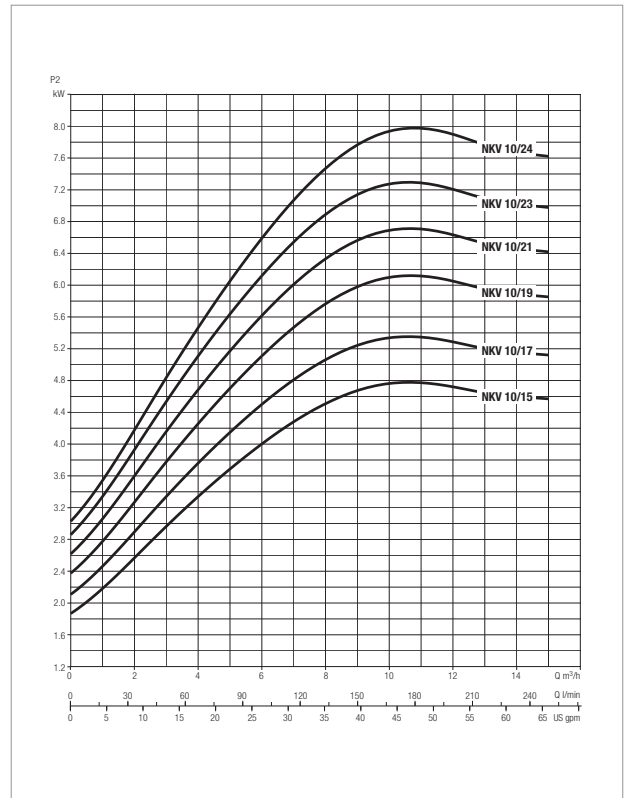
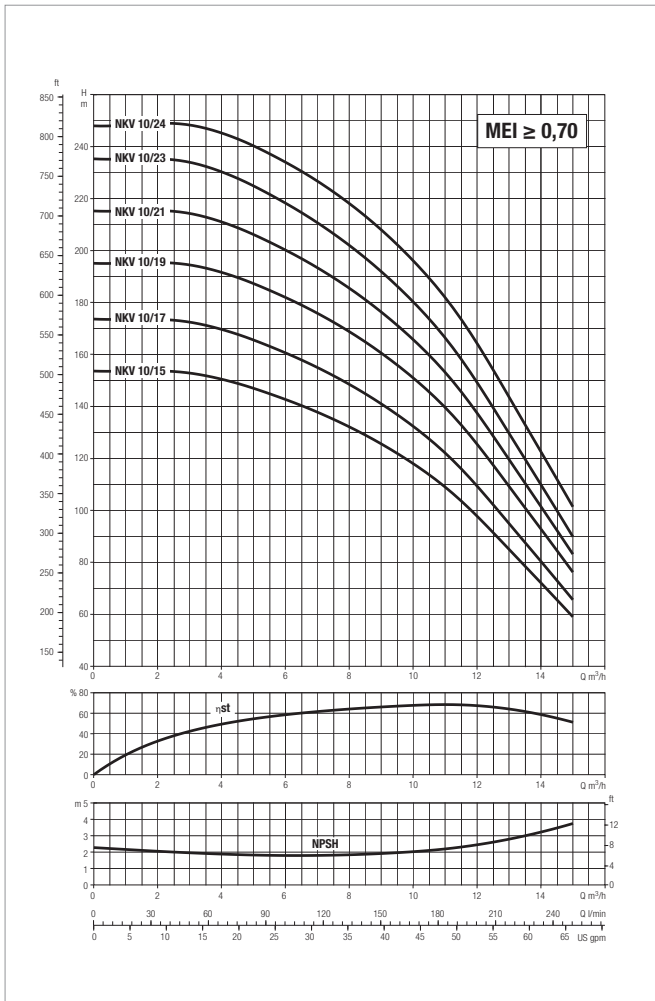

**For hydraulic efficiency see pag. 35**  
The performance curves are based on kinematic viscosity values = 1 mm<sup>2</sup>/s and density equivalent to 1000 kg/m<sup>3</sup>. Tolerance of curves to ISO 9906.

MODEL	VOLTAGE 50 Hz	P2 NOMINAL		In A	Ist A	Motor Frame	MEC Motor	1/min	η max Motor %	cos φ
		kW	HP							
NKV 10/15 T IE3	3 x 380-415Δ	5,50	7,50	10,2	119,8-131	B5	132S	2935	89,2	0,87
NKV 10/17 T IE3	3 x 380-415Δ	5,50	7,50	10,2	119,8-131	B5	132S	2935	89,2	0,87
NKV 10/19 T IE3	3 x 380-415Δ	7,50	10,00	14,4	152-169	B5	132S	2930	90,1	0,84
NKV 10/21 T IE3	3 x 380-415Δ	7,50	10,00	14,4	152-169	B5	132S	2930	90,1	0,84
NKV 10/23 T IE3	3 x 380-415Δ	7,50	10,00	14,4	152-169	B5	132S	2930	90,1	0,84
NKV 10/24 T IE3	3 x 380-415Δ	11,00	15,00	19,7	156-171	B5	160M	2950	91,2	0,89

# NKV 10 - MULTISTAGE CENTRIFUGAL ELECTRICPUMPS WITH VERTICAL AXIS, FOR CIVIL AND INDUSTRIAL PRESSURIZATION UNITS

Liquid temperature range: from - 30°C to +120°C - Maximum working pressure: 25 bar (2500 kPa)

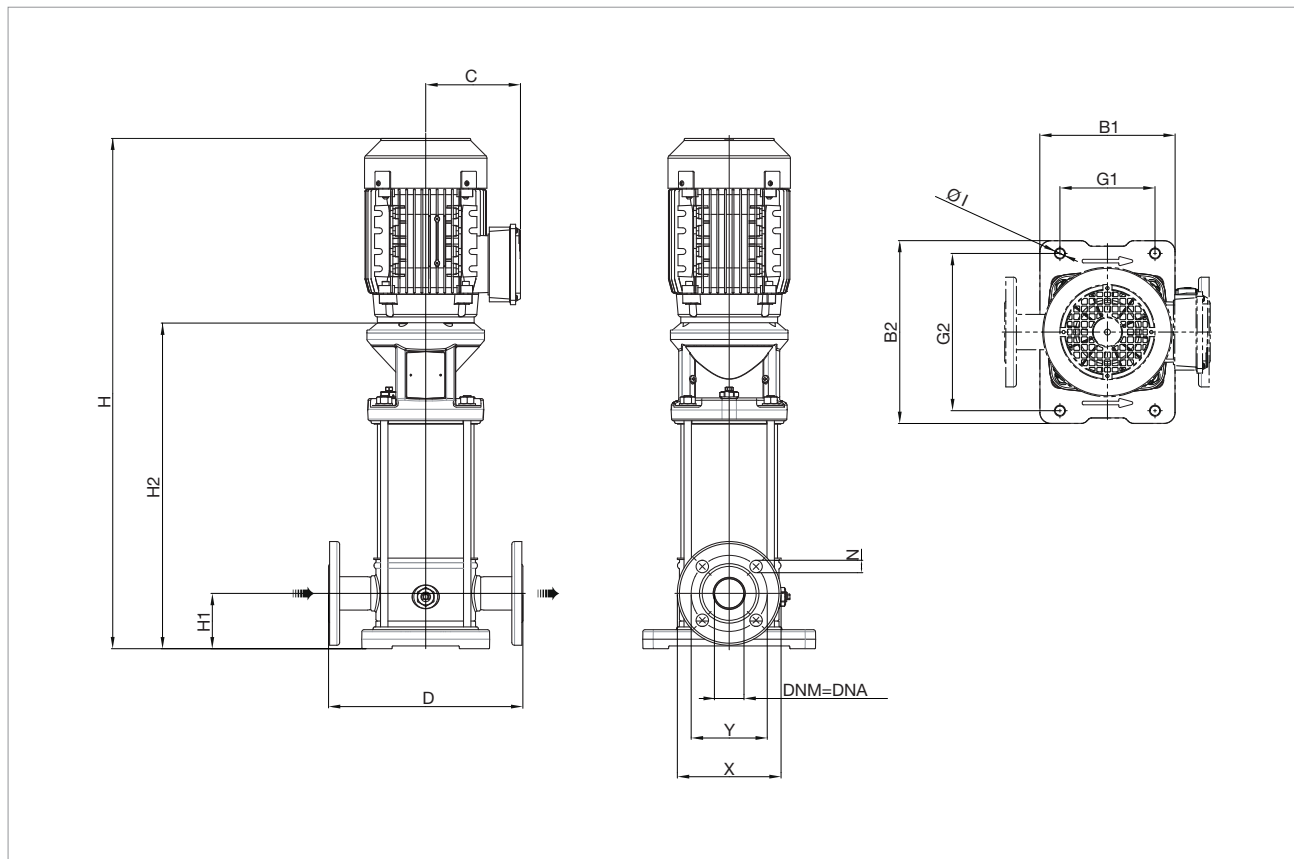

Version F: The pump is supplied without counter flanges (optional accessories, including joints and bolts).

MODEL	STAGE N°	B1	B2	G1	G2	Ø I	C	D	H	H1	H2	DNA = DNM (DN 40)			PACKING DIMENSIONS			VOL. mc	WEIGHT Kg
												X	Y	N	L/A	L/B	H		
NKV 10/2 T IE3	2	185	250	130	215	13	129	280	573	80	341	150	110	18	655	272	275	0,049	22.5
NKV 10/3 T IE3	3	185	250	130	215	13	129	280	603	80	371	150	110	18	655	272	275	0,049	25.1
NKV 10/4 T IE3	4	185	250	130	215	13	138	280	678	80	411	150	110	18	1050	340	490	0,175	29,0
NKV 10/5 T IE3	5	185	250	130	215	13	138	280	708	80	441	150	110	18	1050	340	490	0,175	29.5
NKV 10/6 T IE3	6	185	250	130	215	13	138	280	738	80	471	150	110	18	1050	340	490	0,175	32.5
NKV 10/7 T IE3	7	185	250	130	215	13	138	280	768	80	501	150	110	18	1050	340	490	0,175	33,0
NKV 10/8 T IE3	8	185	250	130	215	13	145	280	847	80	541	150	110	18	1050	340	490	0,175	41.3
NKV 10/9 T IE3	9	185	250	130	215	13	145	280	877	80	571	150	110	18	1050	340	490	0,175	41.8
NKV 10/10 T IE3	10	185	250	130	215	13	145	280	907	80	601	150	110	18	1050	340	490	0,175	46,0
NKV 10/11 T IE3	11	185	250	130	215	13	145	280	937	80	631	150	110	18	1050	340	490	0,175	46.5
NKV 10/12 T IE3	12	185	250	130	215	13	145	280	967	80	661	150	110	18	1050	340	490	0,175	47.5
NKV 10/13 T IE3	13	185	250	130	215	13	145	280	997	80	691	150	110	18	1412	377	530	0,282	48,0
NKV 10/15 T IE3	15	185	250	130	215	13	160	280	1254	80	926	150	110	18	1412	377	530	0,282	76.1
NKV 10/17 T IE3	17	185	250	130	215	13	160	280	1314	80	986	150	110	18	1412	377	530	0,282	77.1
NKV 10/19 T IE3	19	185	250	130	215	13	160	280	1396	80	1046	150	110	18	1610	340	480	0,263	81,0
NKV 10/21 T IE3	21	185	250	130	215	13	160	280	1456	80	1106	150	110	18	1610	340	480	0,263	82.5
NKV 10/23 T IE3	23	185	250	130	215	13	160	280	1516	80	1166	150	110	18	1610	340	480	0,263	83.5
NKV 10/24 T IE3	24	185	250	130	215	13	194	280	1641	80	1216	150	110	18	1820	500	630	0,573	109.5

# NKV 15 - MULTISTAGE CENTRIFUGAL ELECTRIC PUMPS WITH VERTICAL AXIS, FOR CIVIL AND INDUSTRIAL PRESSURIZATION UNITS

Liquid temperature range: from - 30°C to +120°C - Maximum working pressure: 25 bar (2500 kPa)

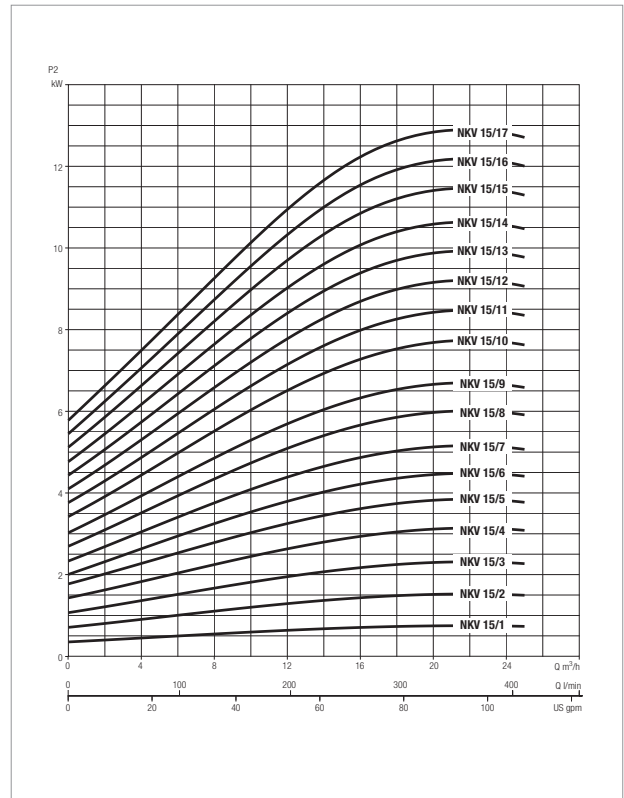
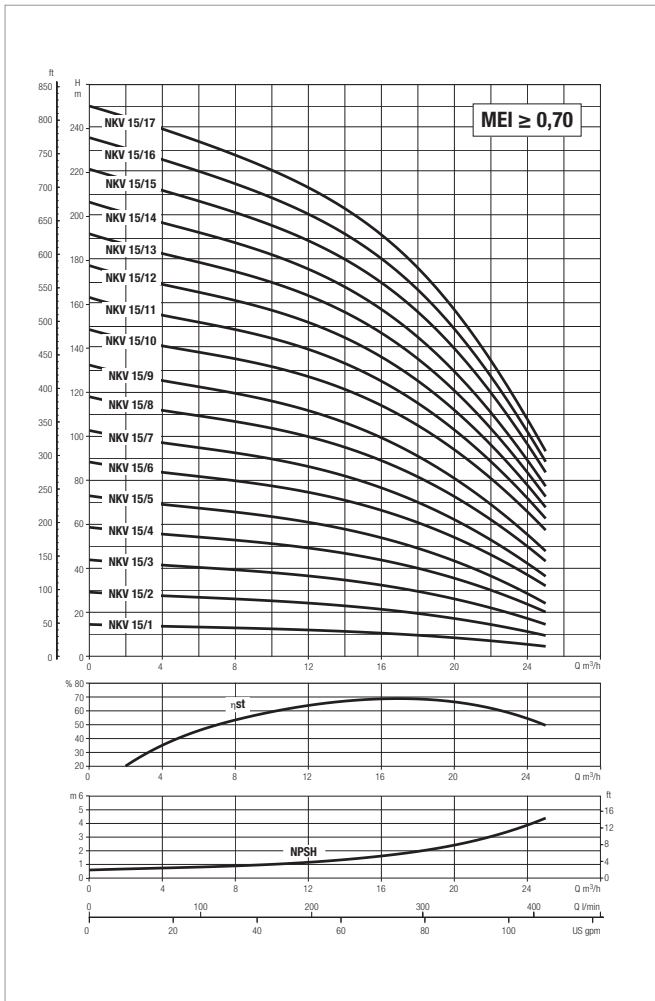

For hydraulic efficiency see pag. 35  
The performance curves are based on kinematic viscosity values = 1 mm<sup>2</sup>/s and density equivalent to 1000 kg/m<sup>3</sup>. Tolerance of curves to ISO 9906.

MODEL	VOLTAGE 50 Hz	P2 NOMINAL		In A	Ist A	Motor Frame	MEC Motor	1/min	η max Motor %	cos φ
		kW	HP							
NKV 15/1 T IE3	3 x 220-240Δ/380-415Y	1,10	1,50	4,1/2,4	28,5-31,5/16,3/17,9	B14	80M	2870	82,7	0,84-0,76
NKV 15/2 T IE3	3 x 220-240Δ/380-415Y	2,20	3,00	7,8-4,6	37,8-42,3	B14	90L	2880	86,5	0,87-0,80
NKV 15/3 T IE3	3 x 380-415Δ	3,00	4,00	5,6	52,9-58	B14	100L	2900	87,1	0,89
NKV 15/4 T IE3	3 x 380-415Δ	4,00	5,50	8	89,6-98,4	B14	112M	2920	88,1	0,81
NKV 15/5 T IE3	3 x 380-415Δ	4,00	5,50	8	89,6-98,4	B14	112M	2920	88,1	0,81
NKV 15/6 T IE3	3 x 380-415Δ	5,50	7,50	10,2	119,8-131	B5	132S	2935	89,2	0,87
NKV 15/7 T IE3	3 x 380-415Δ	5,50	7,50	10,2	119,8-131	B5	132S	2935	89,2	0,87
NKV 15/8 T IE3	3 x 380-415Δ	7,50	10,00	14,4	152-169	B5	132S	2930	90,1	0,84
NKV 15/9 T IE3	3 x 380-415Δ	7,50	10,00	14,4	152-169	B5	132S	2930	90,1	0,84
NKV 15/10 T IE3	3 x 380-415Δ	11,00	15,00	19,7	156-171	B5	160M	2950	91,2	0,89
NKV 15/11 T IE3	3 x 380-415Δ	11,00	15,00	19,7	156-171	B5	160M	2950	91,2	0,89
NKV 15/12 T IE3	3 x 380-415Δ	11,00	15,00	19,7	156-171	B5	160M	2950	91,2	0,89
NKV 15/13 T IE3	3 x 380-415Δ	11,00	15,00	19,7	156-171	B5	160M	2950	91,2	0,89
NKV 15/14 T IE3	3 x 380-415Δ	11,00	15,00	19,7	156-171	B5	160M	2950	91,2	0,89
NKV 15/15 T IE3	3 x 380-415Δ	15,00	20,00	26,7	185-106	B5	160M	2940	91,9	0,89
NKV 15/16 T IE3	3 x 380-415Δ	15,00	20,00	26,7	185-106	B5	160M	2940	91,9	0,89
NKV 15/17 T IE3	3 x 380-415Δ	15,00	20,00	26,7	185-106	B5	160M	2940	91,9	0,89

# NKV 15 - MULTISTAGE CENTRIFUGAL ELECTRICPUMPS WITH VERTICAL AXIS, FOR CIVIL AND INDUSTRIAL PRESSURIZATION UNITS

Liquid temperature range: from - 30°C to +120°C - Maximum working pressure: 25 bar (2500 kPa)

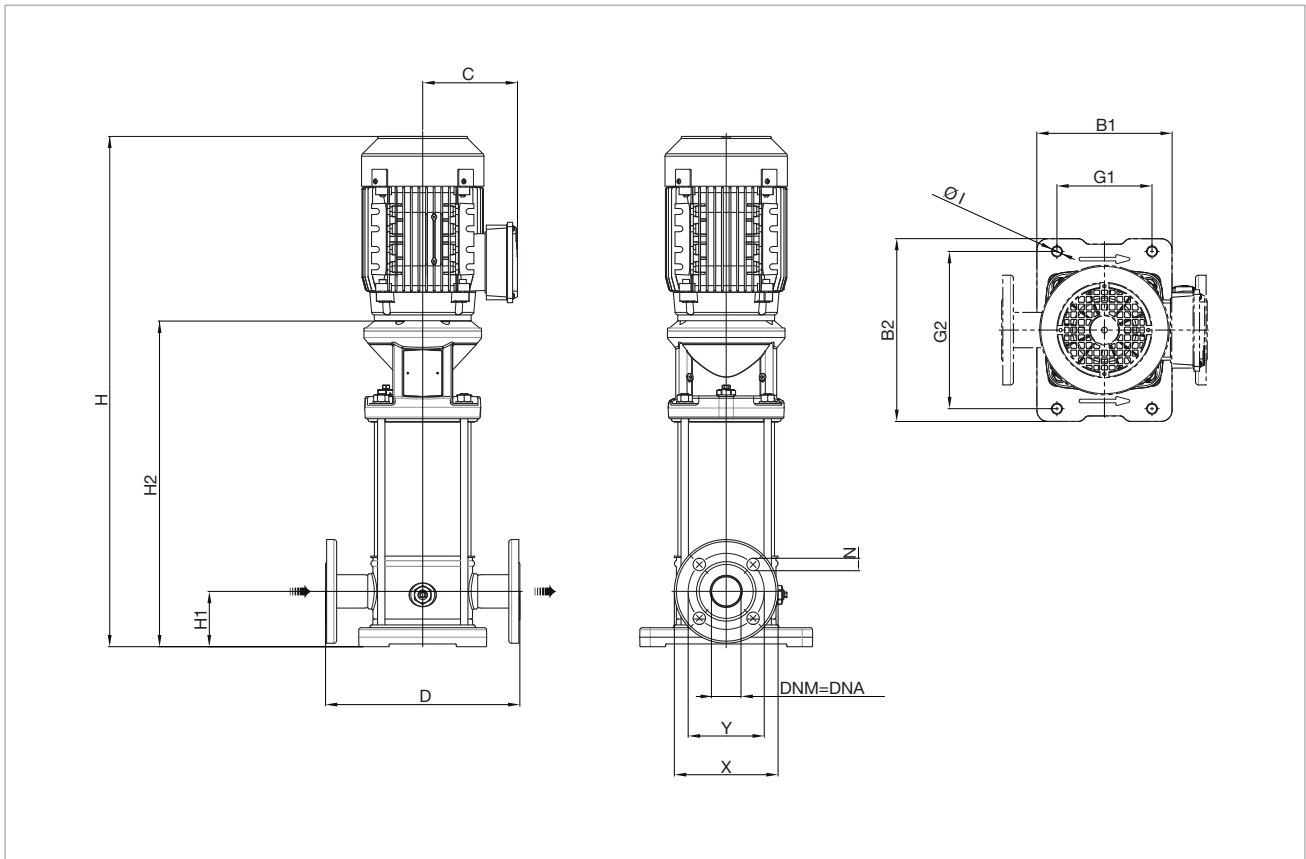

Version F: The pump is supplied without counter flanges (optional accessories, including joints and bolts).

MODEL	STAGE N°	B1	B2	G1	G2	Ø I	C	D	H	H1	H2	DNA = DNM (DN 50)			PACKING DIMENSIONS			VOL. mc	WEIGHT Kg
												X	Y	N	L/A	L/B	H		
NKV 15/1 T IE3	1	185	250	130	215	13	129	300	633	90	401	165	127	19	1050	340	490	0,175	30.6
NKV 15/2 T IE3	2	185	250	130	215	13	138	300	678	90	411	165	127	19	1050	340	490	0,175	37,0
NKV 15/3 T IE3	3	185	250	130	215	13	145	300	775	90	469	165	127	19	1050	340	490	0,175	45.8
NKV 15/4 T IE3	4	185	250	130	215	13	145	300	823	90	517	165	127	19	1050	340	490	0,175	51,0
NKV 15/5 T IE3	5	185	250	130	215	13	145	300	871	90	565	165	127	19	1050	340	490	0,175	52.5
NKV 15/6 T IE3	6	185	250	130	215	13	160	300	1128	90	800	165	127	19	1412	377	530	0,282	81.1
NKV 15/7 T IE3	7	185	250	130	215	13	160	300	1176	90	848	165	127	19	1412	377	530	0,282	82.6
NKV 15/8 T IE3	8	185	250	130	215	13	160	300	1246	90	896	165	127	19	1412	377	530	0,282	86.5
NKV 15/9 T IE3	9	185	250	130	215	13	160	300	1294	90	944	165	127	19	1412	377	530	0,282	88,0
NKV 15/10 T IE3	10	185	250	130	215	13	194	300	1437	90	1012	165	127	19	1820	500	630	0,573	115,0
NKV 15/11 T IE3	11	185	250	130	215	13	194	300	1485	90	1060	165	127	19	1820	500	630	0,573	116.5
NKV 15/12 T IE3	12	185	250	130	215	13	194	300	1533	90	1108	165	127	19	1820	500	630	0,573	118,0
NKV 15/13 T IE3	13	185	250	130	215	13	194	300	1581	90	1156	165	127	19	1820	500	630	0,573	119.5
NKV 15/14 T IE3	14	185	250	130	215	13	194	300	1629	90	1204	165	127	19	1820	500	630	0,573	121,0
NKV 15/15 T IE3	15	185	250	130	215	13	194	300	1728	90	1252	165	127	19	1820	500	630	0,573	131,0
NKV 15/16 T IE3	16	185	250	130	215	13	194	300	1776	90	1300	165	127	19	2550	500	750	0,956	132.5
NKV 15/17 T IE3	17	185	250	130	215	13	194	300	1824	90	1348	165	127	19	2550	500	750	0,956	134,0

# NKV 20 - MULTISTAGE CENTRIFUGAL ELECTRIC PUMPS WITH VERTICAL AXIS, FOR CIVIL AND INDUSTRIAL PRESSURIZATION UNITS

Liquid temperature range: from - 30°C to +120°C - Maximum working pressure: 25 bar (2500 kPa)

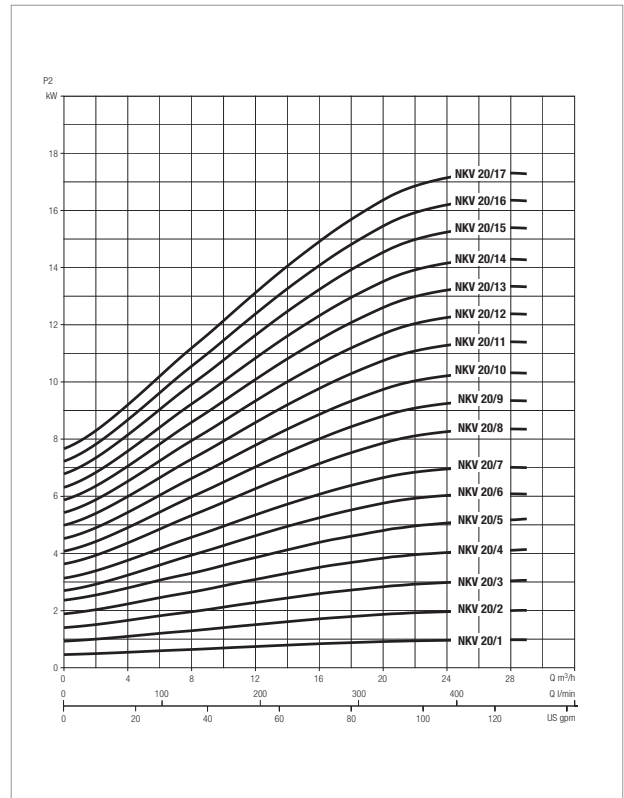
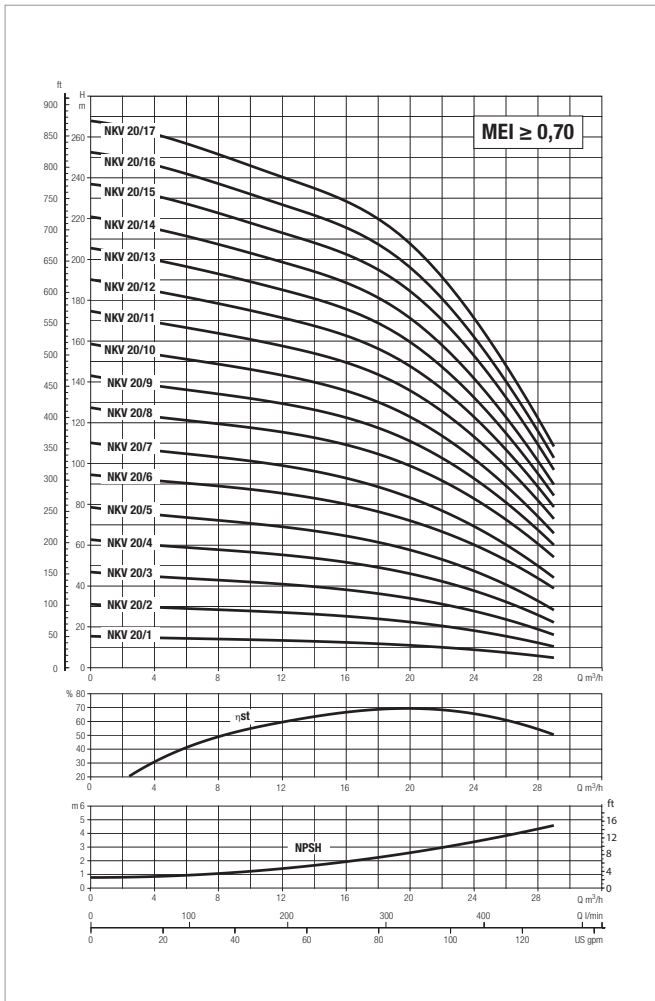

**For hydraulic efficiency see pag. 35**  
The performance curves are based on kinematic viscosity values = 1 mm²/s and density equivalent to 1000 kg/m³. Tolerance of curves to ISO 9906.

MODEL	VOLTAGE 50 Hz	P2 NOMINAL		In A	Ist A	Motor Frame	MEC Motor	1/min	$\eta$ max Motor %	cos $\phi$
		kW	HP							
NKV 20/1 T IE3	3 x 220-240Δ /380-415Y	1,10	1,50	4,1/2,4	28,5-31,5/16,3/17,9	B14	80M	2870	82,7	0,84-0,76
NKV 20/2 T IE3	3 x 220-240Δ /380-415Y	2,20	3,00	7,8-4,6	37,8-42,3	B14	90L	2880	86,5	0,87-0,80
NKV 20/3 T IE3	3 x 380-415Δ	3,00	4,00	5,6	52,9-58	B14	100L	2900	87,1	0,89
NKV 20/4 T IE3	3 x 380-415Δ	4,00	5,50	8	89,6-98,4	B14	112M	2920	88,1	0,81
NKV 20/5 T IE3	3 x 380-415Δ	5,50	7,50	10,2	119,8-131	B5	132S	2935	89,2	0,87
NKV 20/6 T IE3	3 x 380-415Δ	7,50	10,00	14,4	152-169	B5	132S	2930	90,1	0,84
NKV 20/7 T IE3	3 x 380-415Δ	7,50	10,00	14,4	152-169	B5	132S	2930	90,1	0,84
NKV 20/8 T IE3	3 x 380-415Δ	11,00	15,00	19,7	156-171	B5	160M	2950	91,2	0,89
NKV 20/9 T IE3	3 x 380-415Δ	11,00	15,00	19,7	156-171	B5	160M	2950	91,2	0,89
NKV 20/10 T IE3	3 x 380-415Δ	11,00	15,00	19,7	156-171	B5	160M	2950	91,2	0,89
NKV 20/11 T IE3	3 x 380-415Δ	15,00	20,00	26,7	185-106	B5	160M	2940	91,9	0,89
NKV 20/12 T IE3	3 x 380-415Δ	15,00	20,00	26,7	185-106	B5	160M	2940	91,9	0,89
NKV 20/13 T IE3	3 x 380-415Δ	15,00	20,00	26,7	185-106	B5	160M	2940	91,9	0,89
NKV 20/14 T IE3	3 x 380-415Δ	15,00	20,00	26,7	185-106	B5	160M	2940	91,9	0,89
NKV 20/15 T IE3	3 x 380-415Δ	18,50	25,00	33	220-129	B5	160L	2950	92,4	0,88
NKV 20/16 T IE3	3 x 380-415Δ	18,50	25,00	33	220-129	B5	160L	2950	92,4	0,88
NKV 20/17 T IE3	3 x 380-415Δ	18,50	25,00	33	220-129	B5	160L	2950	92,4	0,88

# NKV 20 - MULTISTAGE CENTRIFUGAL ELECTRICPUMPS WITH VERTICAL AXIS, FOR CIVIL AND INDUSTRIAL PRESSURIZATION UNITS

Liquid temperature range: from - 30°C to +120°C - Maximum working pressure: 25 bar (2500 kPa)

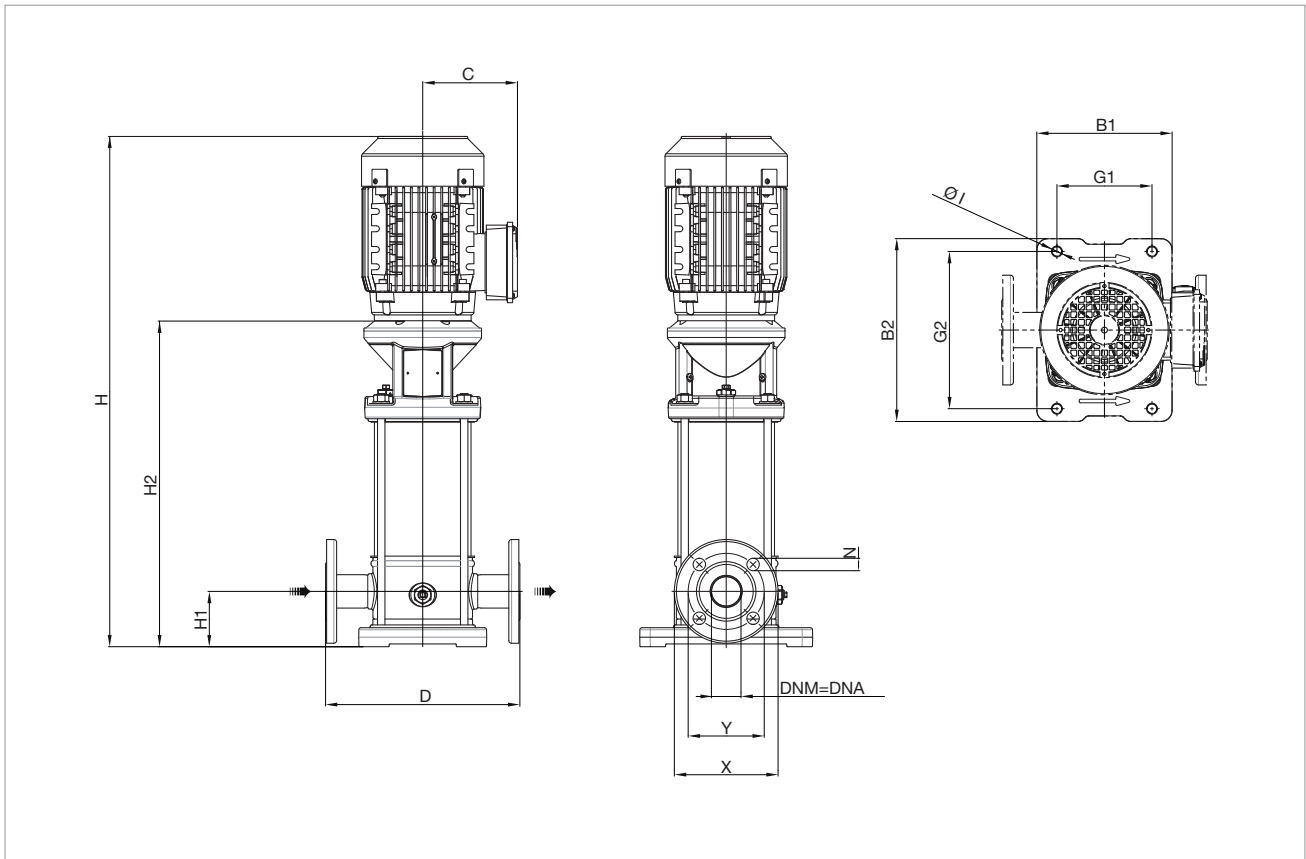

Version F: The pump is supplied without counter flanges (optional accessories, including joints and bolts).

MODEL	STAGE N°	B1	B2	G1	G2	Ø I	C	D	H	H1	H2	DNA = DNM (DN 50)			PACKING DIMENSIONS			VOL. mc	WEIGHT Kg
												X	Y	N	L/A	L/B	H		
NKV 20/1 T IE3	1	185	250	130	215	13	129	300	633	90	401	165	127	19	1050	340	490	0,175	30,6
NKV 20/2 T IE3	2	185	250	130	215	13	138	300	678	90	411	165	127	19	1050	340	490	0,175	37,0
NKV 20/3 T IE3	3	185	250	130	215	13	145	300	775	90	469	165	127	19	1050	340	490	0,175	45,8
NKV 20/4 T IE3	4	185	250	130	215	13	145	300	823	90	517	165	127	19	1412	377	530	0,282	51,0
NKV 20/5 T IE3	5	185	250	130	215	13	160	300	1080	90	752	165	127	19	1412	377	530	0,282	80,1
NKV 20/6 T IE3	6	185	250	130	215	13	160	300	1150	90	800	165	127	19	1412	377	530	0,282	84,0
NKV 20/7 T IE3	7	185	250	130	215	13	160	300	1198	90	848	165	127	19	1412	377	530	0,282	85,0
NKV 20/8 T IE3	8	185	250	130	215	13	194	300	1341	90	916	165	127	19	1820	500	630	0,573	112,5
NKV 20/9 T IE3	9	185	250	130	215	13	194	300	1389	90	964	165	127	19	1820	500	630	0,573	114,0
NKV 20/10 T IE3	10	185	250	130	215	13	194	300	1437	90	1012	165	127	19	1820	500	630	0,573	115,0
NKV 20/11 T IE3	11	185	250	130	215	13	194	300	1536	90	1060	165	127	19	1820	500	630	0,573	125,5
NKV 20/12 T IE3	12	185	250	130	215	13	194	300	1584	90	1108	165	127	19	1820	500	630	0,573	127,0
NKV 20/13 T IE3	13	185	250	130	215	13	194	300	1632	90	1156	165	127	19	1820	500	630	0,573	128,5
NKV 20/14 T IE3	14	185	250	130	215	13	194	300	1680	90	1204	165	127	19	1820	500	630	0,573	130,0
NKV 20/15 T IE3	15	185	250	130	215	13	238	300	1794	90	1252	165	127	19	2550	500	750	0,956	167,0
NKV 20/16 T IE3	16	185	250	130	215	13	238	300	1842	90	1300	165	127	19	2550	500	750	0,956	168,5
NKV 20/17 T IE3	17	185	250	130	215	13	238	300	1890	90	1348	165	127	19	2550	500	750	0,956	170,0

# NKV 32 - MULTISTAGE CENTRIFUGAL ELECTRIC PUMPS WITH VERTICAL AXIS, FOR CIVIL AND INDUSTRIAL PRESSURIZATION UNITS

Liquid temperature range: from - 30°C to + 120°C - Maximum working pressure: 32 bar (3200 kPa)

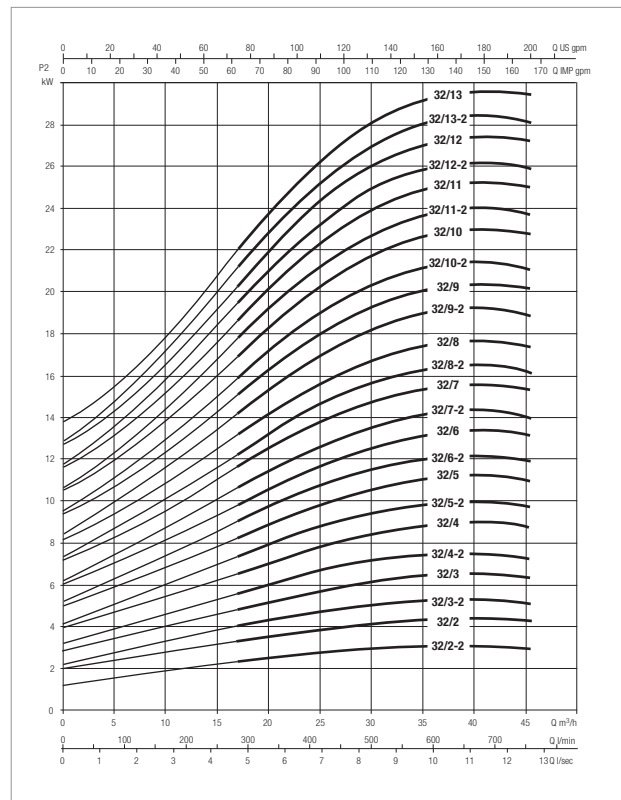
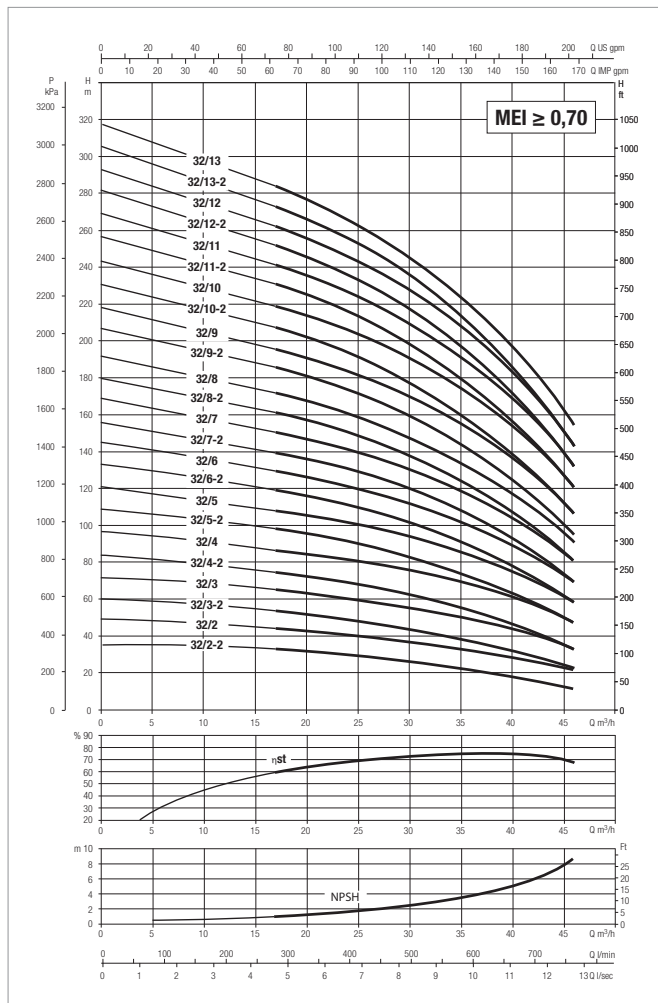

For hydraulic efficiency see pag. 35  
The performance curves are based on kinematic viscosity values = 1 mm²/s and density equivalent to 1000 kg/m³. Tolerance of curves to ISO 9906.

MODEL	VOLTAGE 50 Hz	P2 NOMINAL		In A	Ist A	Motor Frame	MEC Motor	1/min	η max Motor %	cos φ	RPM	
		kW	HP								max	min
NKV 32/2-2 T IE3	3 x 400 V Δ	4,00	5,50	8	89,6-98,4	B14	112M	2920	88,1	0,81	2980	2910
NKV 32/2 T IE3	3 x 400 V Δ	5,50	7,50	10,2	119,8-131	B5	132S	2935	89,2	0,87	2980	2910
NKV 32/3-2 T IE3	3 x 400 V Δ	5,50	7,50	10,2	119,8-131	B5	132S	2935	89,2	0,87	2980	2910
NKV 32/3 T IE3	3 x 400 V Δ	7,50	10,00	14,4	152-169	B5	132S	2930	90,1	0,84	2980	2900
NKV 32/4-2 T IE3	3 x 400 V Δ	7,50	10,00	14,4	152-169	B5	132S	2930	90,1	0,84	2980	2900
NKV 32/4 T IE3	3 x 400 V Δ	11,00	15,00	19,7	156-171	B5	160M	2950	91,2	0,89	2980	2930
NKV 32/5-2 T IE3	3 x 400 V Δ	11,00	15,00	19,7	156-171	B5	160M	2950	91,2	0,89	2980	2930
NKV 32/5 T IE3	3 x 400 V Δ	15,00	20,00	26,7	185-106	B5	160M	2940	91,9	0,89	2980	2940
NKV 32/6-2 T IE3	3 x 400 V Δ	15,00	20,00	26,7	185-106	B5	160M	2940	91,9	0,89	2980	2940
NKV 32/6 T IE3	3 x 400 V Δ	15,00	20,00	26,7	185-106	B5	160M	2940	91,9	0,89	2980	2940
NKV 32/7-2 T IE3	3 x 400 V Δ	15,00	20,00	26,7	185-106	B5	160M	2940	91,9	0,89	2980	2940
NKV 32/7 T IE3	3 x 400 V Δ	18,50	25,00	33	220-129	B5	160L	2950	92,4	0,88	2990	2940
NKV 32/8-2 T IE3	3 x 400 V Δ	18,50	25,00	33	220-129	B5	160L	2950	92,4	0,88	2990	2940
NKV 32/8 T IE3	3 x 400 V Δ	18,50	25,00	33	220-129	B5	160L	2950	92,4	0,88	2990	2940
NKV 32/9-2 T IE3	3 x 400 V Δ	22,00	30,00	38,1	156-171	B5	180M	2955	92,7	0,9	2990	2960
NKV 32/9 T IE3	3 x 400 V Δ	22,00	30,00	38,1	156-171	B5	180M	2955	92,7	0,9	2990	2960
NKV 32/10-2 T IE3	3 x 400 V Δ	22,00	30,00	38,1	156-171	B5	180M	2955	92,7	0,9	2990	2960
NKV 32/10 T IE3	3 x 400 V Δ	30,00	40,00	52,1	185-106	B5	200L	2960	93,3	0,89	2990	2950
NKV 32/11-2 T IE3	3 x 400 V Δ	30,00	40,00	52,1	185-106	B5	200L	2960	93,3	0,89	2990	2950
NKV 32/11 T IE3	3 x 400 V Δ	30,00	40,00	52,1	185-106	B5	200L	2960	93,3	0,89	2990	2950
NKV 32/12-2 T IE3	3 x 400 V Δ	30,00	40,00	52,1	185-106	B5	200L	2960	93,3	0,89	2990	2950
NKV 32/12 T IE3	3 x 400 V Δ	30,00	40,00	52,1	185-106	B5	200L	2960	93,3	0,89	2990	2950
NKV 32/13-2 T IE3	3 x 400 V Δ	30,00	40,00	52,1	185-106	B5	200L	2960	93,3	0,89	2990	2950
NKV 32/13 T IE3	3 x 400 V Δ	30,00	40,00	52,1	185-106	B5	200L	2960	93,3	0,89	2990	2950

# NKV 32 - MULTISTAGE CENTRIFUGAL ELECTRICPUMPS WITH VERTICAL AXIS, FOR CIVIL AND INDUSTRIAL PRESSURIZATION UNITS

Liquid temperature range: from- 30°C to +120°C - Maximum working pressure: 32 bar (3200 kPa)

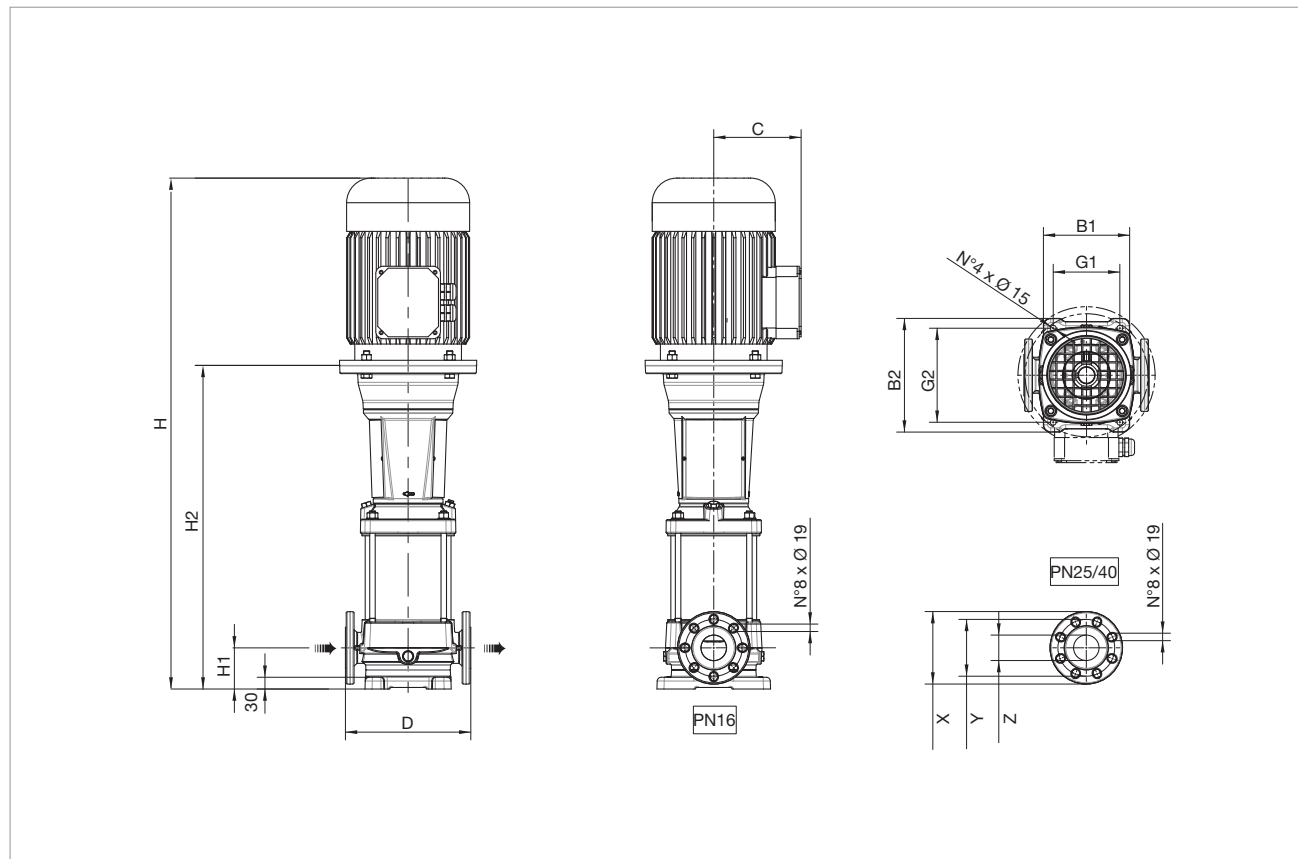

Version F: The pump is supplied without counter flanges (optional accessories, including joints and bolts).

MODEL	STAGE N°	B1	B2	G1	G2	C	D	H	H1	H2	DNA = DNM (DN 65)			PACKING DIMENSIONS			WEIGHT Kg
											X	Y	Z	L/A	L/B	H	
NKV 32/2-2 T IE3	2	220	290	170	240	190	320	947	105	537	185	145	65	1120	500	630	93
NKV 32/2 T IE3	2	220	290	170	240	210	320	1114	105	724	185	145	65	1120	500	630	140
NKV 32/3-2 T IE3	3	220	290	170	240	210	320	1196	105	806	185	145	65	1820	500	630	144
NKV 32/3 T IE3	3	220	290	170	240	188	320	1243	105	806	185	145	65	1820	500	630	125
NKV 32/4-2 T IE3	4	220	290	170	240	188	320	1325	105	888	185	145	65	1820	500	630	132
NKV 32/4 T IE3	4	220	290	170	240	242	320	1345	105	908	185	145	65	1820	500	630	203
NKV 32/5-2 T IE3	5	220	290	170	240	242	320	1427	105	990	185	145	65	1820	500	630	207
NKV 32/5 T IE3	5	220	290	170	240	242	320	1495	105	990	185	145	65	1820	500	630	214
NKV 32/6-2 T IE3	6	220	290	170	240	242	320	1577	105	1072	185	145	65	1820	500	630	218
NKV 32/6 T IE3	6	220	290	170	240	242	320	1577	105	1072	185	145	65	1820	500	630	218
NKV 32/7-2 T IE3	7	220	290	170	240	242	320	1659	105	1154	185	145	65	1820	500	630	222
NKV 32/7 T IE3	7	220	290	170	240	242	320	1703	105	1154	185	145	65	1820	500	630	243
NKV 32/8-2 T IE3	8	220	290	170	240	242	320	1785	105	1236	185	145	65	2550	500	750	247
NKV 32/8 T IE3	8	220	290	170	240	242	320	1785	105	1236	185	145	65	2550	500	750	247
NKV 32/9-2 T IE3	9	220	290	170	240	260	320	1898	105	1318	185	145	65	2550	500	750	283
NKV 32/9 T IE3	9	220	290	170	240	260	320	1898	105	1318	185	145	65	2550	500	750	283
NKV 32/10-2 T IE3	10	220	290	170	240	260	320	1980	105	1400	185	145	65	2550	500	750	290
NKV 32/10 T IE3	10	220	290	170	240	292	320	2075	105	1405	185	145	65	2550	500	750	363
NKV 32/11-2 T IE3	11	220	290	170	240	292	320	2157	105	1487	185	145	65	2550	500	750	367
NKV 32/11 T IE3	11	220	290	170	240	292	320	2157	105	1487	185	145	65	2550	500	750	367
NKV 32/12-2 T IE3	12	220	290	170	240	292	320	2239	105	1569	185	145	65	2550	500	750	371
NKV 32/12 T IE3	12	220	290	170	240	292	320	2239	105	1569	185	145	65	2550	500	750	371
NKV 32/13-2 T IE3	13	220	290	170	240	292	320	2321	105	1651	185	145	65	2550	500	750	375
NKV 32/13 T IE3	13	220	290	170	240	292	320	2321	105	1651	185	145	65	2550	500	750	375

# NKV 45 - MULTISTAGE CENTRIFUGAL ELECTRIC PUMPS WITH VERTICAL AXIS, FOR CIVIL AND INDUSTRIAL PRESSURIZATION UNITS

Liquid temperature range: from - 30°C to + 120°C - Maximum working pressure: 32 bar (3200 kPa)

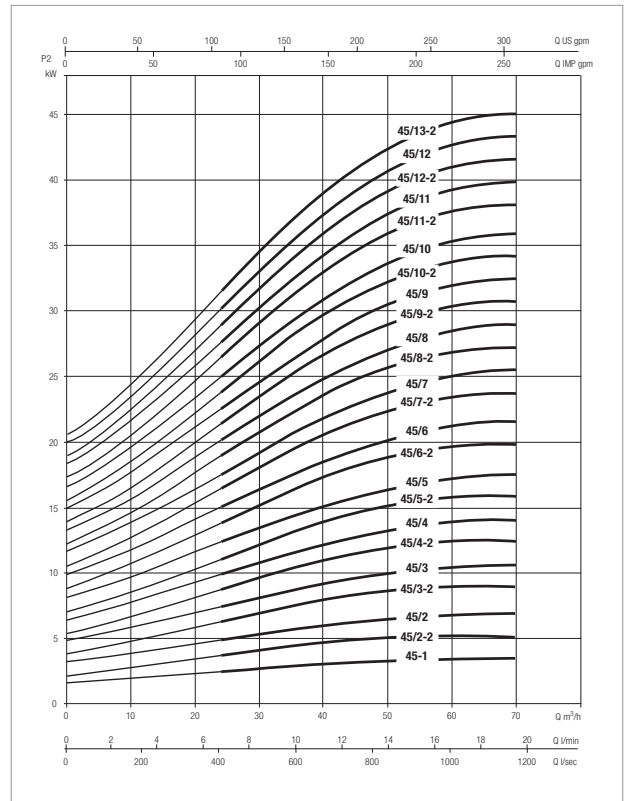
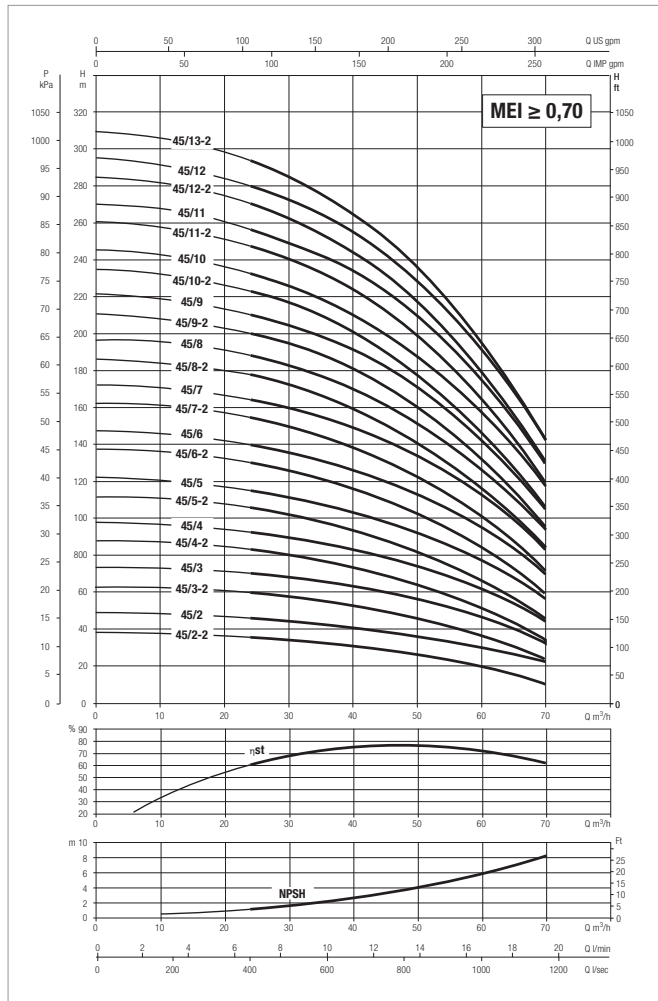

For hydraulic efficiency see pag. 35  
The performance curves are based on kinematic viscosity values = 1 mm<sup>2</sup>/s and density equivalent to 1000 kg/m<sup>3</sup>. Tolerance of curves to ISO 9906.

MODEL	VOLTAGE 50 Hz	P2 NOMINAL		In A	Ist A	Motor Frame	MEC Motor	1/min	η max Motor %	cos φ	RPM	
		kW	HP								max	min
NKV 45/2-2 T IE3	3 x 400 V Δ	5,50	7,50	10,2	119,8-131	B5	132S	2935	89,2	0,87	2980	2910
NKV 45/2 T IE3	3 x 400 V Δ	7,50	10,00	14,4	152-169	B5	132S	2930	90,1	0,84	2980	2900
NKV 45/3-2 T IE3	3 x 400 V Δ	11,00	15,00	19,7	156-171	B5	160M	2950	91,2	0,89	2980	2930
NKV 45/3 T IE3	3 x 400 V Δ	11,00	15,00	19,7	156-171	B5	160M	2950	91,2	0,89	2980	2930
NKV 45/4-2 T IE3	3 x 400 V Δ	15,00	20,00	26,7	185-106	B5	160M	2940	91,9	0,89	2980	2940
NKV 45/4 T IE3	3 x 400 V Δ	15,00	20,00	26,7	185-106	B5	160M	2940	91,9	0,89	2980	2940
NKV 45/5-2 T IE3	3 x 400 V Δ	18,50	25,00	33	220-129	B5	160L	2950	92,4	0,88	2990	2940
NKV 45/5 T IE3	3 x 400 V Δ	18,50	25,00	33	220-129	B5	160L	2950	92,4	0,88	2990	2940
NKV 45/6-2 T IE3	3 x 400 V Δ	22,00	30,00	38,1	156-171	B5	180M	2955	92,7	0,9	2990	2960
NKV 45/6 T IE3	3 x 400 V Δ	22,00	30,00	38,1	156-171	B5	180M	2955	92,7	0,9	2990	2960
NKV 45/7-2 T IE3	3 x 400 V Δ	30,00	40,00	52,1	185-106	B5	200L	2960	93,3	0,89	2990	2950
NKV 45/7 T IE3	3 x 400 V Δ	30,00	40,00	52,1	185-106	B5	200L	2960	93,3	0,89	2990	2950
NKV 45/8-2 T IE3	3 x 400 V Δ	30,00	40,00	52,1	185-106	B5	200L	2960	93,3	0,89	2990	2950
NKV 45/8 T IE3	3 x 400 V Δ	30,00	40,00	52,1	185-106	B5	200L	2960	93,3	0,89	2990	2950
NKV 45/9-2 T IE3	3 x 400 V Δ	37,00	50,00	62,6	220-129	B5	200L	2960	93,7	0,91	2990	2960
NKV 45/9 T IE3	3 x 400 V Δ	37,00	50,00	62,6	220-129	B5	200L	2960	93,7	0,91	2990	2960
NKV 45/10-2 T IE3	3 x 400 V Δ	37,00	50,00	62,6	220-129	B5	200L	2960	93,7	0,91	2990	2960
NKV 45/10 T IE3	3 x 400 V Δ	37,00	50,00	62,6	220-129	B5	200L	2960	93,7	0,91	2990	2960
NKV 45/11-2 T IE3	3 x 400 V Δ	45,00	60,00	78,4	220-129	B5	225M	2965	94	0,88	2990	2960
NKV 45/11 T IE3	3 x 400 V Δ	45,00	60,00	78,4	220-129	B5	225M	2965	94	0,88	2990	2960
NKV 45/12-2 T IE3	3 x 400 V Δ	45,00	60,00	78,4	220-129	B5	225M	2965	94	0,88	2990	2960
NKV 45/12 T IE3	3 x 400 V Δ	45,00	60,00	78,4	220-129	B5	225M	2965	94	0,88	2990	2960
NKV 45/13-2 T IE3	3 x 400 V Δ	45,00	60,00	78,4	220-129	B5	225M	2965	94	0,88	2990	2960

# NKV 45 - MULTISTAGE CENTRIFUGAL ELECTRICPUMPS WITH VERTICAL AXIS, FOR CIVIL AND INDUSTRIAL PRESSURIZATION UNITS

Liquid temperature range: from- 30°C to +120°C - Maximum working pressure: 32 bar (3200 kPa)

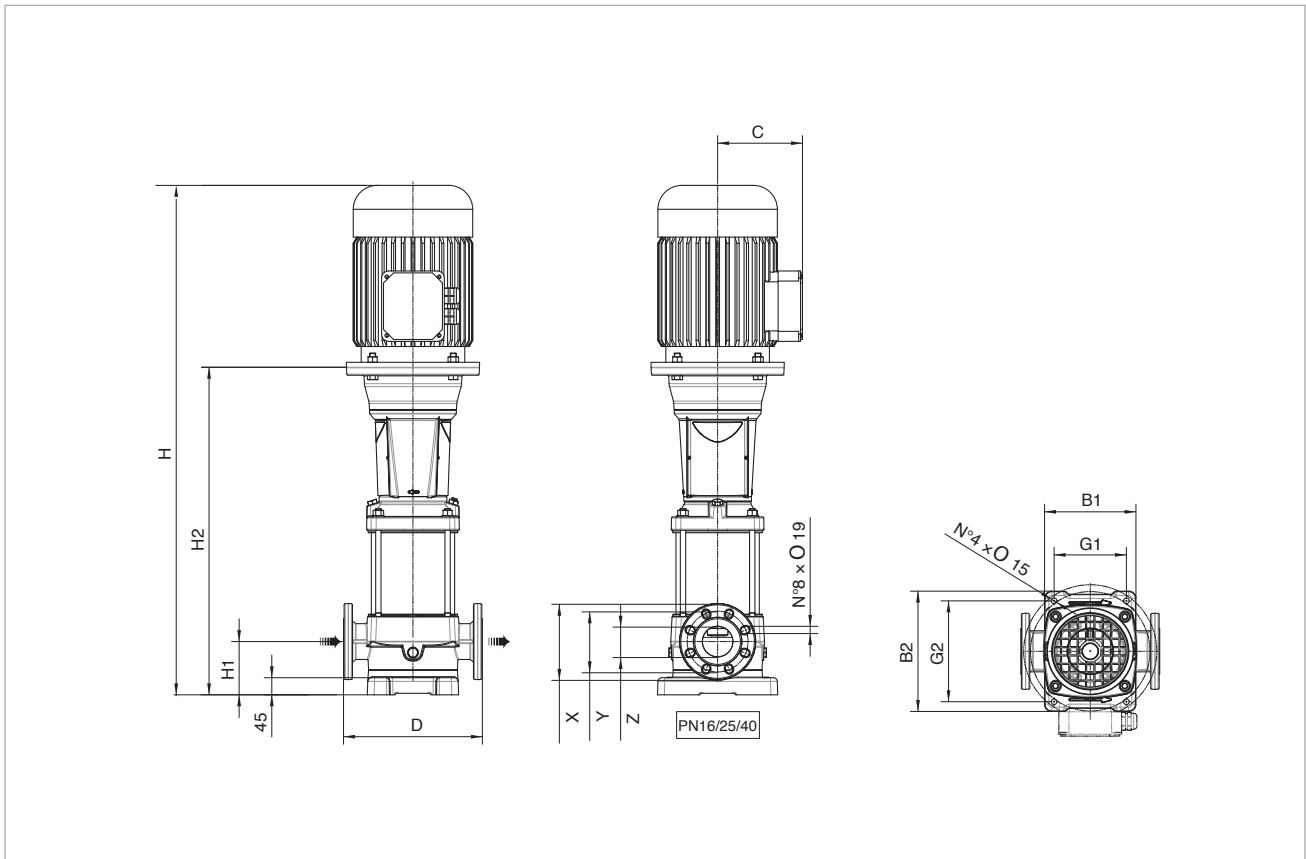

Version F: The pump is supplied without counter flanges (optional accessories, including joints and bolts).

MODEL	STAGE N°	B1	B2	G1	G2	C	D	H	H1	H2	DNA = DNM (DN 80)			PACKING DIMENSIONS			WEIGHT Kg
											X	Y	Z	L/A	L/B	H	
NKV 45/2-2 T IE3	2	240	316	190	265	161	365	1149	140	759	200	160	80	1820	500	630	146
NKV 45/2 T IE3	2	240	316	190	265	188	365	1196	140	759	200	160	80	1820	500	630	127
NKV 45/3-2 T IE3	3	240	316	190	265	242	365	1298	140	861	200	160	80	1820	500	630	205
NKV 45/3 T IE3	3	240	316	190	265	242	365	1298	140	861	200	160	80	1820	500	630	205
NKV 45/4-2 T IE3	4	240	316	190	265	242	365	1448	140	943	200	160	80	1820	500	630	216
NKV 45/4 T IE3	4	240	316	190	265	242	365	1448	140	943	200	160	80	1820	500	630	216
NKV 45/5-2 T IE3	5	240	316	190	265	242	365	1574	140	1025	200	160	80	1820	500	630	241
NKV 45/5 T IE3	5	240	316	190	265	242	365	1574	140	1025	200	160	80	1820	500	630	241
NKV 45/6-2 T IE3	6	240	316	190	265	260	365	1687	140	1107	200	160	80	1820	500	630	276
NKV 45/6 T IE3	6	240	316	190	265	260	365	1687	140	1107	200	160	80	1820	500	630	276
NKV 45/7-2 T IE3	7	240	316	190	265	292	365	1864	140	1194	200	160	80	2550	500	750	356
NKV 45/7 T IE3	7	240	316	190	265	292	365	1864	140	1194	200	160	80	2550	500	750	356
NKV 45/8-2 T IE3	8	240	316	190	265	292	365	1946	140	1276	200	160	80	2550	500	750	360
NKV 45/8 T IE3	8	240	316	190	265	292	365	1946	140	1276	200	160	80	2550	500	750	360
NKV 45/9-2 T IE3	9	240	316	190	265	292	365	2028	140	1358	200	160	80	2550	500	750	384
NKV 45/9 T IE3	9	240	316	190	265	292	365	2028	140	1358	200	160	80	2550	500	750	384
NKV 45/10-2 T IE3	10	240	316	190	265	292	365	2110	140	1440	200	160	80	2550	500	750	388
NKV 45/10 T IE3	10	240	316	190	265	292	365	2110	140	1440	200	160	80	2550	500	750	388
NKV 45/11-2 T IE3	11	240	316	190	265	315	365	2232	140	1522	200	160	80	2550	500	750	449
NKV 45/11 T IE3	11	240	316	190	265	315	365	2232	140	1522	200	160	80	2550	500	750	449
NKV 45/12-2 T IE3	12	240	316	190	265	315	365	2314	140	1604	200	160	80	2550	500	750	453
NKV 45/12 T IE3	12	240	316	190	265	315	365	2314	140	1604	200	160	80	2550	500	750	453
NKV 45/13-2 T IE3	13	240	316	190	265	315	365	2396	140	1686	200	160	80	2550	500	750	457

# NKV 65 - MULTISTAGE CENTRIFUGAL ELECTRIC PUMPS WITH VERTICAL AXIS, FOR CIVIL AND INDUSTRIAL PRESSURIZATION UNITS

Liquid temperature range: from - 30°C to +120°C - Maximum working pressure: 25 bar (2500 kPa)

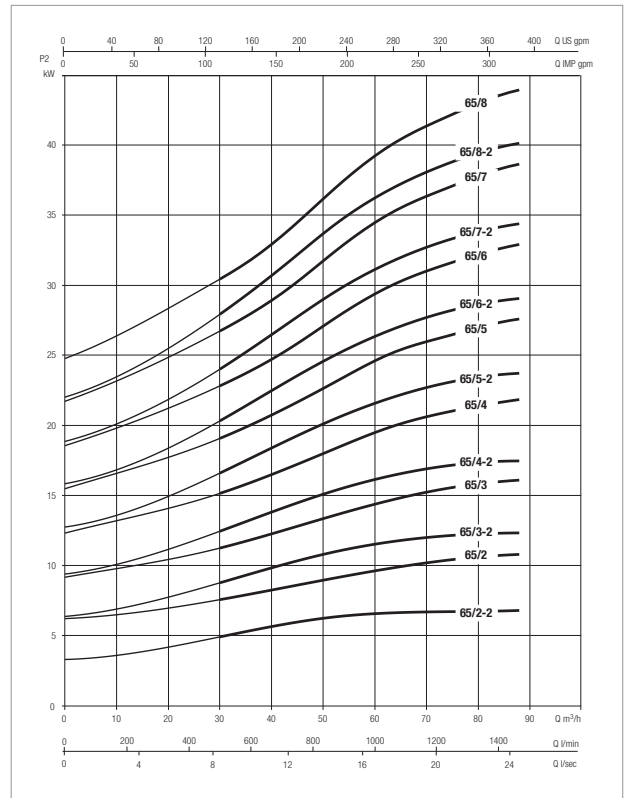
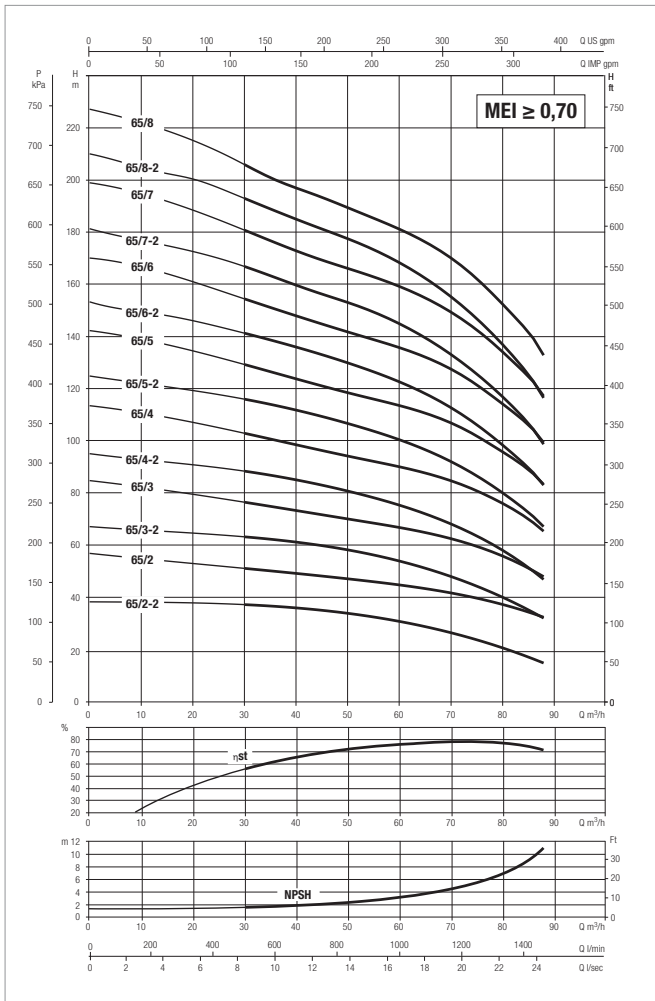

For hydraulic efficiency see pag. 35  
The performance curves are based on kinematic viscosity values = 1 mm<sup>2</sup>/s and density equivalent to 1000 kg/m<sup>3</sup>. Tolerance of curves to ISO 9906.

MODEL	VOLTAGE 50 Hz	P2 NOMINAL		In A	Ist A	Motor Frame	MEC Motor	1/min	η max Motor %	cos φ	RPM	
		kW	HP								max	min
NKV 65/2-2 T IE3	3 x 400 V Δ	7,50	10,00	14,4	152-169	B5	132S	2930	90,1	0,84	2980	2900
NKV 65/2 T IE3	3 x 400 V Δ	11,00	15,00	19,7	156-171	B5	160M	2950	91,2	0,89	2980	2930
NKV 65/3-2 T IE3	3 x 400 V Δ	15,00	20,00	26,7	185-106	B5	160M	2940	91,9	0,89	2980	2940
NKV 65/3 T IE3	3 x 400 V Δ	18,50	25,00	33	220-129	B5	160L	2950	92,4	0,88	2990	2940
NKV 65/4-2 T IE3	3 x 400 V Δ	18,50	25,00	33	220-129	B5	160L	2950	92,4	0,88	2990	2940
NKV 65/4 T IE3	3 x 400 V Δ	22,00	30,00	38,1	156-171	B5	180M	2955	92,7	0,9	2990	2960
NKV 65/5-2 T IE3	3 x 400 V Δ	30,00	40,00	52,1	185-106	B5	200L	2960	93,3	0,89	2990	2950
NKV 65/5 T IE3	3 x 400 V Δ	30,00	40,00	52,1	185-106	B5	200L	2960	93,3	0,89	2990	2950
NKV 65/6-2 T IE3	3 x 400 V Δ	30,00	40,00	52,1	185-106	B5	200L	2960	93,3	0,89	2990	2950
NKV 65/6 T IE3	3 x 400 V Δ	37,00	50,00	62,6	220-129	B5	200L	2960	93,7	0,91	2990	2960
NKV 65/7-2 T IE3	3 x 400 V Δ	37,00	50,00	62,6	220-129	B5	200L	2960	93,7	0,91	2990	2960
NKV 65/7 T IE3	3 x 400 V Δ	45,00	60,00	78,4	220-129	B5	225M	2965	94	0,88	2990	2960
NKV 65/8-2 T IE3	3 x 400 V Δ	45,00	60,00	78,4	220-129	B5	225M	2965	94	0,88	2990	2960
NKV 65/8 T IE3	3 x 400 V Δ	45,00	60,00	78,4	220-129	B5	225M	2965	94	0,88	2990	2960

# NKV 65 - MULTISTAGE CENTRIFUGAL ELECTRICPUMPS WITH VERTICAL AXIS, FOR CIVIL AND INDUSTRIAL PRESSURIZATION UNITS

Liquid temperature range: from - 30°C to +120°C - Maximum working pressure: 25 bar (2500 kPa)

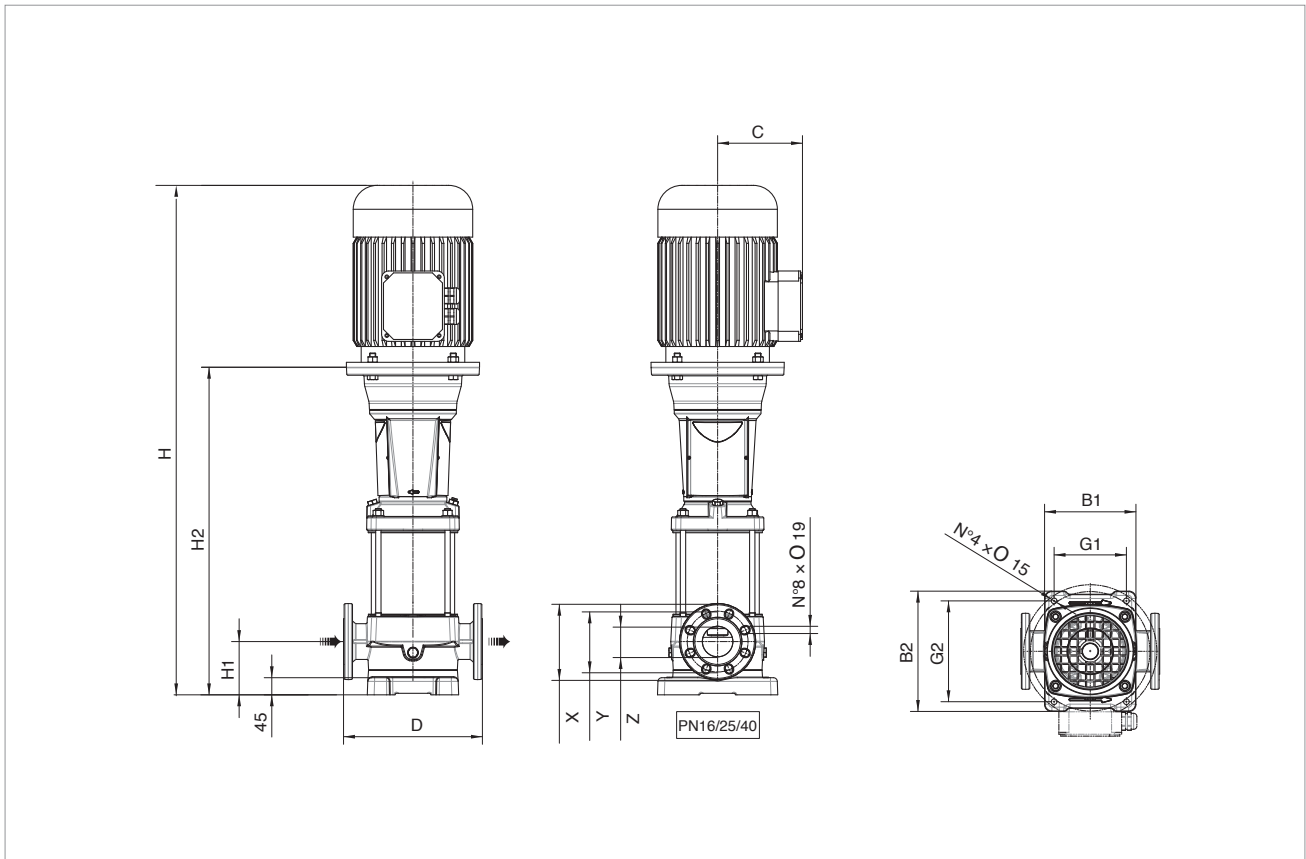

Version F: The pump is supplied without counter flanges (optional accessories, including joints and bolts).

MODEL	STAGE N°	B1	B2	G1	G2	C	D	H	H1	H2	DNA = DNM (DN 100)			PACKING DIMENSIONS			WEIGHT Kg
											X	Y	Z	L/A	L/B	H	
NKV 65/2-2 T IE3	2	240	316	190	265	161	365	1266,2	140	829,2	230	180	100	1820	500	630	84
NKV 65/2 T IE3	2	240	316	190	265	198	365	1354,2	140	849,2	230	180	100	1820	500	630	155
NKV 65/3-2 T IE3	3	240	316	190	265	198	365	1446,3	140	941,3	230	180	100	1820	500	630	171
NKV 65/3 T IE3	3	240	316	190	265	235	365	1490,3	140	941,3	230	180	100	1820	500	630	213
NKV 65/4-2 T IE3	4	240	316	190	265	235	365	1582,4	140	1033,4	230	180	100	1820	500	630	213
NKV 65/4 T IE3	4	240	316	190	265	238	365	1613,4	140	1033,4	230	180	100	1820	500	630	255
NKV 65/5-2 T IE3	5	240	316	190	265	300	365	1800,5	140	1130,5	230	180	100	2550	500	750	471
NKV 65/5 T IE3	5	240	316	190	265	300	365	1800,5	140	1130,5	230	180	100	2550	500	750	471
NKV 65/6-2 T IE3	6	240	316	190	265	300	365	1892,6	140	1222,6	230	180	100	2550	500	750	471
NKV 65/6 T IE3	6	240	316	190	265	300	365	1892,6	140	1222,6	230	180	100	2550	500	750	517
NKV 65/7-2 T IE3	7	240	316	190	265	300	365	1984,7	140	1314,7	230	180	100	2550	500	750	517
NKV 65/7 T IE3	7	240	316	190	265	335	365	2024,7	140	1314,7	230	180	100	2550	500	750	653
NKV 65/8-2 T IE3	8	240	316	190	265	335	365	2116,8	140	1406,8	230	180	100	2550	500	750	653
NKV 65/8 T IE3	8	240	316	190	265	335	365	2116,8	140	1406,8	230	180	100	2550	500	750	653

# NKV 95 - MULTISTAGE CENTRIFUGAL ELECTRIC PUMPS WITH VERTICAL AXIS, FOR CIVIL AND INDUSTRIAL PRESSURIZATION UNITS

Liquid temperature range: from - 30°C to +120°C - Maximum working pressure: 25 bar (2500 kPa)

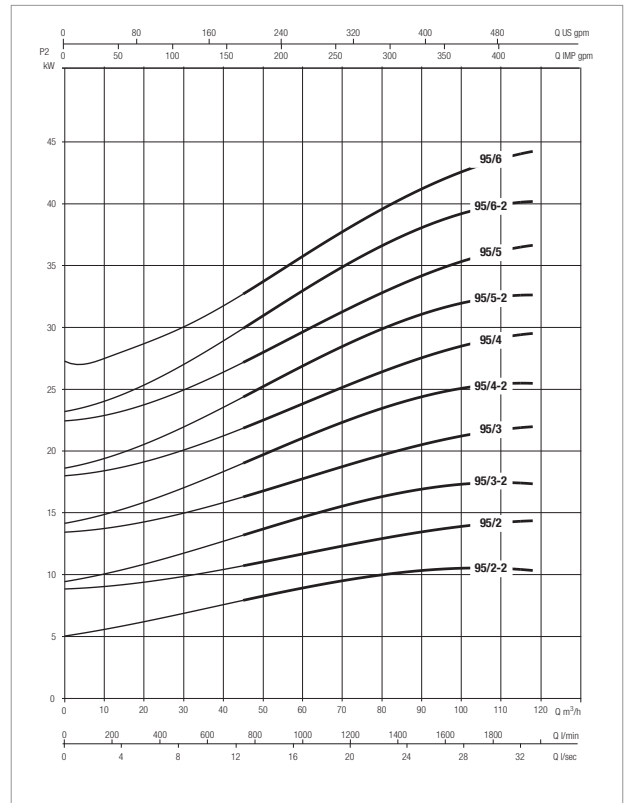
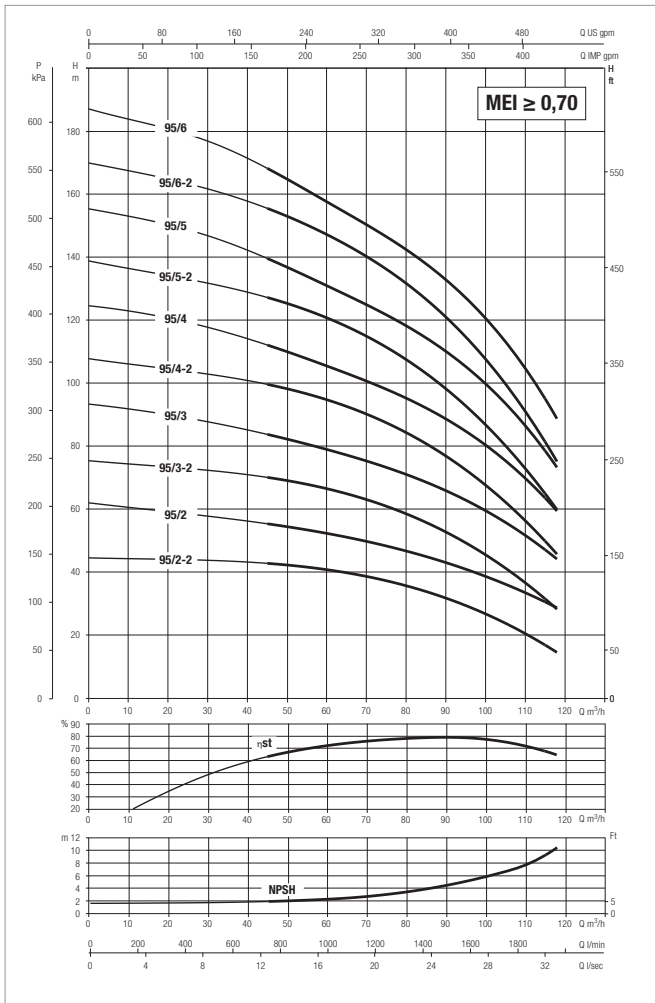

For hydraulic efficiency see pag. 35

The performance curves are based on kinematic viscosity values = 1 mm<sup>2</sup>/s and density equivalent to 1000 kg/m<sup>3</sup>. Tolerance of curves to ISO 9906.

MODEL	VOLTAGE 50 Hz	P2 NOMINAL		In A	Ist A	Motor Frame	MEC Motor	1/min	$\eta$ max Motor %	cos $\varphi$	RPM	
		kW	HP								max	min
NKV 95/2-2 T IE3	3 x 400 V $\Delta$	11,00	15,00	19,7	156-171	B5	160M	2950	91,2	0,89	2980	2930
NKV 95/2 T IE3	3 x 400 V $\Delta$	15,00	20,00	26,7	185-106	B5	160M	2940	91,9	0,89	2980	2940
NKV 95/3-2 T IE3	3 x 400 V $\Delta$	18,50	25,00	33	220-129	B5	160L	2950	92,4	0,88	2990	2940
NKV 95/3 T IE3	3 x 400 V $\Delta$	22,00	30,00	38,1	156-171	B5	180M	2955	92,7	0,9	2990	2960
NKV 95/4-2 T IE3	3 x 400 V $\Delta$	30,00	40,00	52,1	185-106	B5	200L	2960	93,3	0,89	2990	2950
NKV 95/4 T IE3	3 x 400 V $\Delta$	30,00	40,00	52,1	185-106	B5	200L	2960	93,3	0,89	2990	2950
NKV 95/5-2 T IE3	3 x 400 V $\Delta$	37,00	50,00	62,6	220-129	B5	200L	2960	93,7	0,91	2990	2960
NKV 95/5 T IE3	3 x 400 V $\Delta$	37,00	50,00	62,6	220-129	B5	200L	2960	93,7	0,91	2990	2960
NKV 95/6-2 T IE3	3 x 400 V $\Delta$	45,00	60,00	78,4	220-129	B5	225M	2965	94	0,88	2990	2960
NKV 95/6 T IE3	3 x 400 V $\Delta$	45,00	60,00	78,4	220-129	B5	225M	2965	94	0,88	2990	2960

# NKV 95 - MULTISTAGE CENTRIFUGAL ELECTRICPUMPS WITH VERTICAL AXIS, FOR CIVIL AND INDUSTRIAL PRESSURIZATION UNITS

Liquid temperature range: from - 30°C to +120°C - Maximum working pressure: 25 bar (2500 kPa)

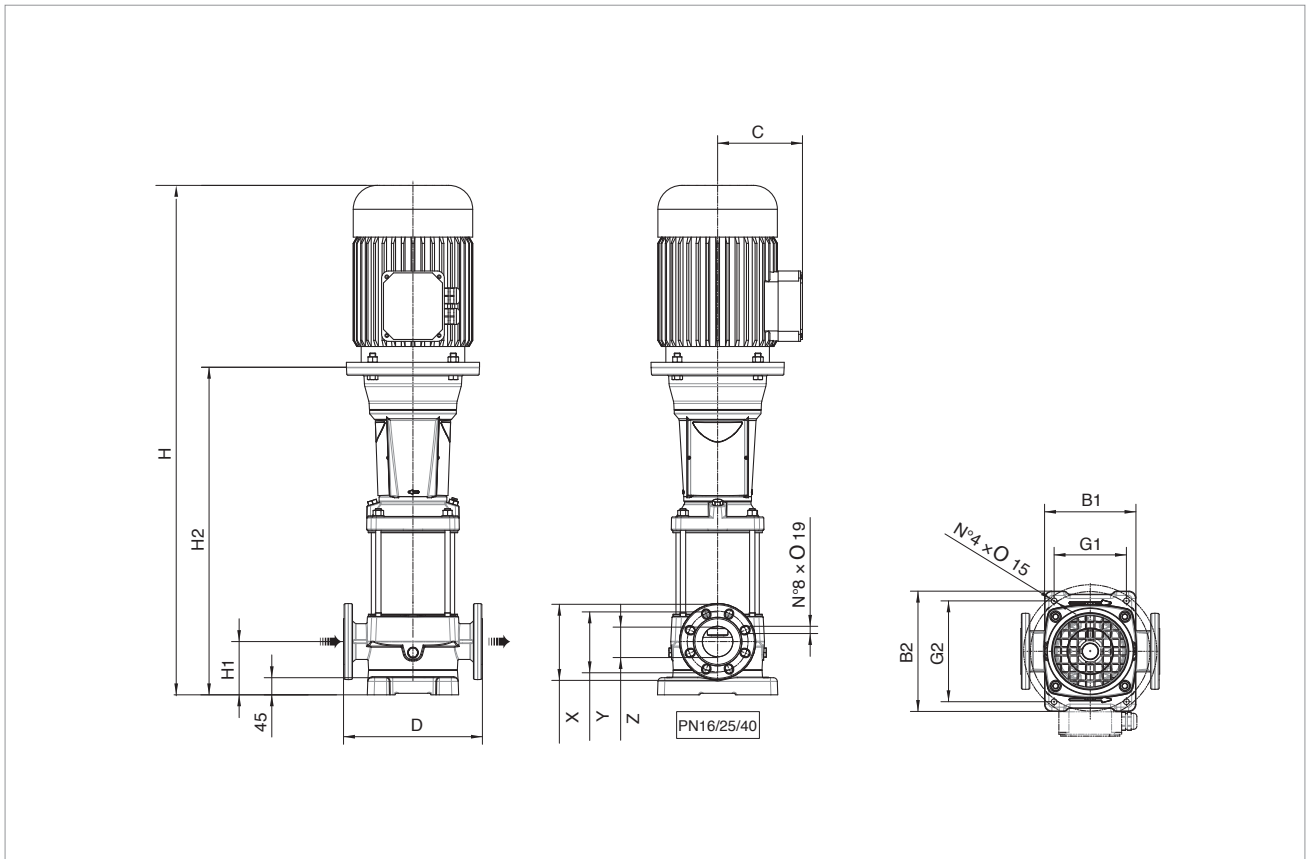

Version F: The pump is supplied without counter flanges (optional accessories, including joints and bolts).

MODEL	STAGE N°	B1	B2	G1	G2	C	D	H	H1	H2	DNA = DNM (DN 100)			PACKING DIMENSIONS			WEIGHT Kg
											X	Y	Z	L/A	L/B	H	
NKV 95/2-2 T IE3	2	260	341	199	280	198	380	1354,2	140	849,2	230	180	100	1820	500	630	186
NKV 95/2 T IE3	2	260	341	199	280	198	380	1354,2	140	849,2	230	180	100	1820	500	630	196
NKV 95/3-2 T IE3	3	260	341	199	280	235	380	1490,3	140	941,3	230	180	100	1820	500	630	217
NKV 95/3 T IE3	3	260	341	199	280	238	380	1521,3	140	941,3	230	180	100	1820	500	630	238
NKV 95/4-2 T IE3	4	260	341	199	280	300	380	1708,4	140	1038,4	230	180	100	1820	500	630	343
NKV 95/4 T IE3	4	260	341	199	280	300	380	1708,4	140	1038,4	230	180	100	1820	500	630	343
NKV 95/5-2 T IE3	5	260	341	199	280	300	380	1800,5	140	1130,5	230	180	100	2550	500	750	379
NKV 95/5 T IE3	5	260	341	199	280	300	380	1800,5	140	1130,5	230	180	100	2550	500	750	379
NKV 95/6-2 T IE3	6	260	341	199	280	335	380	1932,6	140	1222,6	230	180	100	2550	500	750	455
NKV 95/6 T IE3	6	260	341	199	280	335	380	1932,6	140	1222,6	230	180	100	2550	500	750	455

# HYDRAULIC EFFICIENCY

---

EU REGULATION 547/2012 – MEI

### GENERAL INFORMATION

With the aim of defining a comparable performance threshold value among all water pumps present on the market, an index has been created which considers the size of the pump and its specific rotation speed: the MEI (Minimum Efficiency Index).

The regulation applies to centrifugal pumps for pumping clean water included in these product categories:

- END SUCTION OWN BEARING PUMPS (ESOB)
- END SUCTION CLOSE COUPLED PUMPS (ESCC)
- END SUCTION CLOSE COUPLED INLINE PUMPS (ESCCI)
- VERTICAL MULTISTAGE PUMPS (MS-V)
- SUBMERSIBLE MULTISTAGE PUMPS (MSS)

MEI represents a dimensionless indicator for hydraulic performance and is a measurement of the sizing of the pump with respect to its performance. The higher the MEI value, the better the sizing of the pump with respect to its performance and the lower the yearly energy consumption due to use of the pump. The upper limit of the MEI values is theoretically open, and depends only on physical and technological limits.

**The minimum efficiency index (MEI) is based on the maximum diameter of the impeller. Multistage vertical pumps must undergo tests in a version with 3 stages.**

The reference value for the most efficient water pumps is  $MEI \geq 0.70$ .

The efficiency of a pump with a trimmed impeller is usually lower than that of a pump with the full impeller diameter. The trimming of the impeller adapts the pump to a fixed work point, with a consequent lower energy consumption.

The operation of this water pump with variable operating points may be more efficient and economic if controlled, for example, by means of a variable speed motor which adapts pump operation to the system.

You can find information on reference efficiency at the address: [www.dabpumps.com](http://www.dabpumps.com) or contact our sales network.

The efficiency graphs for  $MEI=0.7$  and  $MEI=0.4$  for the different types of pumps are available on the site: [www.europump.org/efficiencycharts](http://www.europump.org/efficiencycharts)

PUMP MODEL	N° STAGES	MEI	$\eta_{PL}$	$\eta_{BEP}$	$\eta_{OL}$
NKV 1/2 T IE3	2	$\geq 0,70$	44,78	47,27	46,72
NKV 1/3 T IE3	3		44,78	47,27	46,72
NKV 1/4 T IE3	4		44,78	47,27	46,72
NKV 1/5 T IE3	5		44,78	47,27	46,72
NKV 1/6 T IE3	6		44,78	47,27	46,72
NKV 1/7 T IE3	7		44,78	47,27	46,72
NKV 1/8 T IE3	8		44,78	47,27	46,72
NKV 1/9 T IE3	9		44,78	47,27	46,72
NKV 1/10 T IE3	10		44,78	47,27	46,72
NKV 1/11 T IE3	11		44,78	47,27	46,72
NKV 1/12 T IE3	12		44,78	47,27	46,72
NKV 1/13 T IE3	13		44,78	47,27	46,72
NKV 1/14 T IE3	14		44,78	47,27	46,72
NKV 1/15 T IE3	15		44,78	47,27	46,72
NKV 1/17 T IE3	17		44,78	47,27	46,72
NKV 1/19 T IE3	19		44,78	47,27	46,72
NKV 1/22 T IE3	22		44,78	47,27	46,72

# HYDRAULIC EFFICIENCY

EU REGULATION 547/2012 – MEI

PUMP MODEL	N° STAGES	MEI	$\eta_{PL}$	$\eta_{BEP}$	$\eta_{OL}$
NKV 1/23 T IE3	23	$\geq 0,70$	44,78	47,27	46,72
NKV 1/25 T IE3	25		44,78	47,27	46,72
NKV 1/27 T IE3	27		44,78	47,27	46,72
NKV 1/30 T IE3	30		44,78	47,27	46,72
NKV 1/32 T IE3	32		44,78	47,27	46,72
NKV 1/34 T IE3	34		44,78	47,27	46,72
NKV 1/37 T IE3	37		44,78	47,27	46,72

PUMP MODEL	N° STAGES	MEI	$\eta_{PL}$	$\eta_{BEP}$	$\eta_{OL}$
NKV 3/2 T IE3	2	$\geq 0,70$	50,8	53,44	52,79
NKV 3/3 T IE3	3		50,8	53,44	52,79
NKV 3/4 T IE3	4		50,8	53,44	52,79
NKV 3/5 T IE3	5		50,8	53,44	52,79
NKV 3/6 T IE3	6		50,8	53,44	52,79
NKV 3/7 T IE3	7		50,8	53,44	52,79
NKV 3/8 T IE3	8		50,8	53,44	52,79
NKV 3/9 T IE3	9		50,8	53,44	52,79
NKV 3/10 T IE3	10		50,8	53,44	52,79
NKV 3/11 T IE3	11		50,8	53,44	52,79
NKV 3/12 T IE3	12		50,8	53,44	52,79
NKV 3/13 T IE3	13		50,8	53,44	52,79
NKV 3/14 T IE3	14		50,8	53,44	52,79
NKV 3/15 T IE3	15		50,8	53,44	52,79
NKV 3/16 T IE3	16		50,8	53,44	52,79
NKV 3/17 T IE3	17		50,8	53,44	52,79
NKV 3/18 T IE3	18		50,8	53,44	52,79
NKV 3/19 T IE3	19		50,8	53,44	52,79
NKV 3/21 T IE3	21		50,8	53,44	52,79
NKV 3/23 T IE3	23		50,8	53,44	52,79
NKV 3/25 T IE3	25		50,8	53,44	52,79
NKV 3/27 T IE3	27		50,8	53,44	52,79
NKV 3/29 T IE3	29		50,8	53,44	52,79
NKV 3/31 T IE3	31	50,8	53,44	52,79	
NKV 3/33 T IE3	33	50,8	53,44	52,79	

# HYDRAULIC EFFICIENCY

EU REGULATION 547/2012 – MEI

PUMP MODEL	N° STAGES	MEI	$\eta_{PL}$	$\eta_{BEP}$	$\eta_{OL}$
NKV 6/2 T IE3	2	$\geq 0,70$	60,47	64,55	62,87
NKV 6/3 T IE3	3		60,47	64,55	62,87
NKV 6/4 T IE3	4		60,47	64,55	62,87
NKV 6/5 T IE3	5		60,47	64,55	62,87
NKV 6/6 T IE3	6		60,47	64,55	62,87
NKV 6/7 T IE3	7		60,47	64,55	62,87
NKV 6/8 T IE3	8		60,47	64,55	62,87
NKV 6/9 T IE3	9		60,47	64,55	62,87
NKV 6/10 T IE3	10		60,47	64,55	62,87
NKV 6/11 T IE3	11		60,47	64,55	62,87
NKV 6/12 T IE3	12		60,47	64,55	62,87
NKV 6/13 T IE3	13		60,47	64,55	62,87
NKV 6/14 T IE3	14		60,47	64,55	62,87
NKV 6/15 T IE3	15		60,47	64,55	62,87
NKV 6/16 T IE3	16		60,47	64,55	62,87
NKV 6/17 T IE3	17		60,47	64,55	62,87
NKV 6/18 T IE3	18		60,47	64,55	62,87
NKV 6/19 T IE3	19		60,47	64,55	62,87
NKV 6/20 T IE3	20		60,47	64,55	62,87
NKV 6/21 T IE3	21		60,47	64,55	62,87
NKV 6/23 T IE3	23		60,47	64,55	62,87
NKV 6/25 T IE3	25		62,5	66,2	64,98
NKV 6/28 T IE3	28		62,5	66,2	64,98
NKV 6/30 T IE3	30		62,5	66,2	64,98
NKV 6/33 T IE3	33		62,5	66,2	64,98
NKV 6/36 T IE3	36		62,5	66,2	64,98

PUMP MODEL	N° STAGES	MEI	$\eta_{PL}$	$\eta_{BEP}$	$\eta_{OL}$
NKV 10/2 T IE3	2	$\geq 0,70$	64,72	67,58	66,82
NKV 10/3 T IE3	3		64,72	67,58	66,82
NKV 10/4 T IE3	4		64,72	67,58	66,82
NKV 10/5 T IE3	5		64,72	67,58	66,82
NKV 10/6 T IE3	6		64,72	67,58	66,82
NKV 10/7 T IE3	7		64,72	67,58	66,82

# HYDRAULIC EFFICIENCY

EU REGULATION 547/2012 – MEI

PUMP MODEL	N° STAGES	MEI	$\eta_{PL}$	$\eta_{BEP}$	$\eta_{OL}$
NKV 10/8 T IE3	8	$\geq 0,70$	64,72	67,58	66,82
NKV 10/9 T IE3	9		64,72	67,58	66,82
NKV 10/10 T IE3	10		64,72	67,58	66,82
NKV 10/11 T IE3	11		64,72	67,58	66,82
NKV 10/12 T IE3	12		64,72	67,58	66,82
NKV 10/13 T IE3	13		64,72	67,58	66,82
NKV 10/15 T IE3	15		64,72	67,58	66,82
NKV 10/17 T IE3	17		64,72	67,58	66,82
NKV 10/19 T IE3	19		64,72	67,58	66,82
NKV 10/21 T IE3	21		64,72	67,58	66,82
NKV 10/23 T IE3	23		64,72	67,58	66,82
NKV 10/24 T IE3	24		64,72	67,58	66,82

PUMP MODEL	N° STAGES	MEI	$\eta_{PL}$	$\eta_{BEP}$	$\eta_{OL}$
NKV 15/1 T IE3	1	$\geq 0,70$	61,59	65,63	64,65
NKV 15/2 T IE3	2		61,59	65,63	64,65
NKV 15/3 T IE3	3		61,59	65,63	64,65
NKV 15/4 T IE3	4		61,59	65,63	64,65
NKV 15/5 T IE3	5		61,59	65,63	64,65
NKV 15/6 T IE3	6		64,68	69,13	68,28
NKV 15/7 T IE3	7		64,68	69,13	68,28
NKV 15/8 T IE3	8		64,68	69,13	68,28
NKV 15/9 T IE3	9		64,68	69,13	68,28
NKV 15/10 T IE3	10		64,68	69,13	68,28
NKV 15/11 T IE3	11		64,68	69,13	68,28
NKV 15/12 T IE3	12		64,68	69,13	68,28
NKV 15/13 T IE3	13		64,68	69,13	68,28
NKV 15/14 T IE3	14		64,68	69,13	68,28
NKV 15/15 T IE3	15		64,68	69,13	68,28
NKV 15/16 T IE3	16		64,68	69,13	68,28
NKV 15/17 T IE3	17		64,68	69,13	68,28

# HYDRAULIC EFFICIENCY

EU REGULATION 547/2012 – MEI

PUMP MODEL	N° STAGES	MEI	$\eta_{PL}$	$\eta_{BEP}$	$\eta_{OL}$
NKV 20/1 T IE3	1	$\geq 0,70$	61,78	66,22	65,64
NKV 20/2 T IE3	2		61,78	66,22	65,64
NKV 20/3 T IE3	3		61,78	66,22	65,64
NKV 20/4 T IE3	4		61,78	66,22	65,64
NKV 20/5 T IE3	5		61,78	66,22	65,64
NKV 20/6 T IE3	6		64,59	69,58	68,67
NKV 20/7 T IE3	7		64,59	69,58	68,67
NKV 20/8 T IE3	8		64,59	69,58	68,67
NKV 20/9 T IE3	9		64,59	69,58	68,67
NKV 20/10 T IE3	10		64,59	69,58	68,67
NKV 20/11 T IE3	11		64,59	69,58	68,67
NKV 20/12 T IE3	12		64,59	69,58	68,67
NKV 20/13 T IE3	13		64,59	69,58	68,67
NKV 20/14 T IE3	14		64,59	69,58	68,67
NKV 20/15 T IE3	15		64,59	69,58	68,67
NKV 20/16 T IE3	16		64,59	69,58	68,67
NKV 20/17 T IE3	17		64,59	69,58	68,67

MODELLO POMPA	NUMERO STADI	MEI	$\eta_{PL}$	$\eta_{BEP}$	$\eta_{OL}$
NKV 32/3	3	$\geq 0,70$	70,08	74,12	73,16
NKV 32/2-2	2		65,89	69,98	69,26
NKV 32/2	2		70,08	74,12	73,16
NKV 32/3-2	3		67,38	71,10	70,20
NKV 32/4-2	4		68,05	71,78	70,92
NKV 32/4	4		70,08	74,12	73,16
NKV 32/5-2	5		68,40	72,20	71,44
NKV 32/5	5		70,08	74,12	73,16
NKV 32/6-2	6		68,62	72,49	71,81
NKV 32/6	6		70,08	74,12	73,16
NKV 32/7-2	7		68,82	72,70	72,04
NKV 32/7	7		70,08	74,12	73,16
NKV 32/8-2	8		68,96	72,86	72,22
NKV 32/8	8		70,08	74,12	73,16
NKV 32/9-2	9		69,06	72,98	72,37

# HYDRAULIC EFFICIENCY

EU REGULATION 547/2012 – MEI

PUMP MODEL	N° STAGES	MEI	$\eta_{PL}$	$\eta_{BEP}$	$\eta_{OL}$
NKV 32/9	9	$\geq 0,70$	70,08	74,12	73,16
NKV 32/10-2	10		69,15	73,09	72,47
NKV 32/10	10		70,08	74,12	73,16
NKV 32/11-2	11		69,24	73,17	72,55
NKV 32/11	11		70,08	74,12	73,16
NKV 32/12-2	12		69,29	73,25	72,63
NKV 32/12	12		70,08	74,12	73,16
NKV 32/13-2	13		69,37	73,31	72,66
NKV 32/13	13		70,08	74,12	73,16

PUMP MODEL	N° STAGES	MEI	$\eta_{PL}$	$\eta_{BEP}$	$\eta_{OL}$
NKV 45/3	3	$\geq 0,70$	73,47	76,37	75,25
NKV 45/2-2	2		69,13	71,65	70,46
NKV 45/2	2		73,47	76,37	75,25
NKV 45/3-2	3		69,79	73,42	72,55
NKV 45/4-2	4		70,11	74,21	73,56
NKV 45/4	4		73,47	76,37	75,25
NKV 45/5-2	5		70,36	74,67	74,14
NKV 45/5	5		73,47	76,37	75,25
NKV 45/6-2	6		70,50	74,96	74,52
NKV 45/6	6		73,47	76,37	75,25
NKV 45/7-2	7		70,56	75,16	74,80
NKV 45/7	7		73,47	76,37	75,25
NKV 45/8-2	8		70,67	75,32	75,00
NKV 45/8	8		73,47	76,37	75,25
NKV 45/9-2	9		70,70	75,43	75,16
NKV 45/9	9		73,47	76,37	75,25
NKV 45/10-2	10		70,73	75,52	75,28
NKV 45/10	10		73,47	76,37	75,25
NKV 45/11-2	11		70,82	75,60	75,38
NKV 45/11	11		73,47	76,37	75,25
NKV 45/12-2	12	70,84	75,66	75,46	
NKV 45/12	12	73,47	76,37	75,25	
NKV 45/13-2	13	70,85	75,71	75,54	

# HYDRAULIC EFFICIENCY

EU REGULATION 547/2012 – MEI

PUMP MODEL	N° STAGES	MEI	$\eta_{PL}$	$\eta_{BEP}$	$\eta_{OL}$
NKV 65/3	3	$\geq 0,70$	73,71	78,96	77,11
NKV 65/2-2	2		70,92	77,97	77,08
NKV 65/2	2		73,71	78,96	77,11
NKV 65/3-2	3		72,27	77,22	76,17
NKV 65/4-2	4		72,52	77,33	76,58
NKV 65/4	4		73,71	78,96	77,11
NKV 65/5-2	5		73,15	77,48	76,31
NKV 65/5	5		73,71	78,96	77,11
NKV 65/6-2	6		73,78	77,69	75,76
NKV 65/6	6		73,71	78,96	77,11
NKV 65/7-2	7		73,84	77,87	75,86
NKV 65/7	7		73,71	78,96	77,11
NKV 65/8-2	8		73,87	78,00	75,94
NKV 65/8	8		73,71	78,96	77,11

PUMP MODEL	N° STAGES	MEI	$\eta_{PL}$	$\eta_{BEP}$	$\eta_{OL}$
NKV 95/3	3	$\geq 0,70$	74,38	79,43	77,94
NKV 95/2-2	2		72,37	78,87	77,79
NKV 95/2	2		74,38	79,43	77,94
NKV 95/3-2	3		73,03	78,58	77,65
NKV 95/4-2	4		73,56	78,64	77,44
NKV 95/4	4		74,38	79,43	77,94
NKV 95/5-2	5		73,82	78,74	77,41
NKV 95/5	5		74,38	79,43	77,94
NKV 95/6-2	6		73,90	78,83	77,51
NKV 95/6	6		74,38	79,43	77,94



# DAB

PUMPS SELECTOR

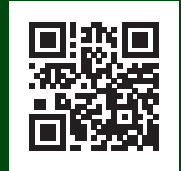

## On-line selection tool



**DAB PUMPS LTD.**

Unit 6 Gilberd Court  
Newcomen Way, Severalls Park  
CO4 9WN  
Colchester  
ordersuk@dwtgroup.com  
Tel. +44 0333 777 5010



**DAB PUMPS IBERICA S.L.**

Calle Verano 18-20-22  
28850 - Torrejón de Ardoz - Madrid  
Spain  
Info.spain@dwtgroup.com  
Tel. +34 91 6569545



**DAB PUMPS DE MÉXICO, S.A. DE C.V.**

Av Amsterdam 101 Local 4  
Col. Hipódromo Condesa,  
Del. Cuauhtémoc CP 06170  
Ciudad de México  
Tel. +52 55 6719 0493



**DAB PUMPS BV**

"Hofveld 6 C1  
1702 Groot Bijgaarden - Belgium  
info.belgium@dwtgroup.com  
Tel. +32 2 4668353



**DAB PUMPS HUNGARY KFT.**

H-8800  
Nagykanizsa, Buda Ernő u.5  
Hungary  
Tel. +36 93501700



**DAB PUMPS SOUTH AFRICA (PTY) LTD**

Twenty One industrial Estate,  
16 Purlin Street, Unit B, Warehouse 4  
Olifantsfontein - 1667 - South Africa  
info.sa@dwtgroup.com  
Tel. +27 12 361 3997



**DAB PUMPS B.V.**

Statenlaan, 4  
5223 LA, 's-Hertogenbosch  
Nederland  
info.nl@dabpumps.com  
Tel. +31 416 387280



**DAB PUMPS POLAND Sp. z o.o.**

Ul. Janka Muzykanta 60  
02188 Warszawa - Poland  
sprzedaz@dabpumps.com.pl



**DAB PUMPS (QINGDAO) CO. LTD.**

No.10 Xindong Road  
Jiulong Town,  
Jiaozhou City  
266319 Qingdao (Shandong) - China  
sales.cn@dwtgroup.com  
Tel. +86 400 186 8280



**DAB PUMPS FRANCE SAS**

Tour Ariane, Paris la Défense 9  
5, Place de la Pyramide  
92800 Puteaux - France  
info.fr@dabpumps.com  
Tel. +33 (0)6 79 63 05 46  
+33 (0)7 89 01 53 35



**DAB PUMPS INC.**

3226 Benchmark Drive  
Ladson, SC 29456 - USA  
info.usa@dwtgroup.com  
Tel. 1 - 843-797-5002  
Fax 1-843-797-3366



**DAB PUMPS OCEANIA PTY LTD**

426 South Gippsland Highway,  
Dandenong South VIC 3175 - Australia  
info.oceania@dwtgroup.com  
Tel. +61 1300 378 677



**DAB PUMPS GMBH**

Am Nordpark 3  
D - 41069 Mönchengladbach - Germany  
info.germany@dwtgroup.com  
Tel. +49 2161 47388-0  
Fax +49 2161 47388-36



**DAB PUMPS CANADA INC.**

333 Bay Street, Suite 4600, Toronto,  
Ontario, M5H 2S5, - Canada  
orders@dwtgroup.ca  
Tel. 1-833-322-7867



**PT DAB PUMPS INDONESIA**

Satrio Tower lantai 26  
unit C-D, Jl. Prof. Dr. Satrio Kav. C4,  
Kel. Kuningan Timur, Kec. Setiabudi, Kota Adm.  
Jakarta Selatan, Prov. DKI Jakarta. - Indonesia  
Tel. +62 2129222850