

CME /CM-GE / DCME / DCM-GE

ELECTRONIC IN-LINE PUMPS FOR CIRCULATION SYSTEMS



TECHNICAL DATA

Flow rate: 1.2 to 360 m³/h

Head: up to 34 m

Type of pumped liquid: clean, free of solid or abrasive substances, non-viscous, non-aggressive, non-crystallised and chemically neutral.

Glycol percentage (maximum): 30%

Liquid temperature range: from -10°C to +140°C

Maximum ambient temperature: +40°C

Maximum working pressure: 16 bar / 1600 kPa

Flanging or threading: flange from DN 65 to DN 150 PN 16

Protection degree: IP55

Insulation class: F

Impeller material: cast iron

Single phase power input: 230 V 50 Hz

Three phase power input: 3x230 V 50 Hz / 3x400 V 50 Hz

Installation: fixed horizontal or vertical as long as the motor is positioned above the pump

Electronic in-line pumps for water circulation in air conditioning and heating systems, water recirculation in the presence of solar thermal panels (solar collectors) and for circulation of drinkable hot water in commercial building service. Twin version are the one with the D letter. Possibility of remote control thanks to the DConnect service (DConnect Box supplied separately).

CONSTRUCTION FEATURES OF THE PUMP

Suction and delivery ports are flanged with threaded connectors for control gauges. Pump body and motor support in cast iron, impeller in cast iron or technopolymer depending on the model. Standardized mechanical seal according to DIN 24960 in carbon-silicon carbide with EPDM OR rings. Counter flanges on request: DN 65, DN 80, DN 100, DN 125, DN 150 with PN 16.

CONSTRUCTION FEATURES OF THE MOTOR

Air-cooled four-pole asynchronous motor with AISI 304 stainless steel motor shaft.

CONSTRUCTION FEATURES OF THE ELECTRONIC

MCE-C variable frequency drive installed as standard for greater pump operating efficiency. It is equipped with a display for configuration and control. MEC-C is settable in pressure regulation mode, differentiates constant, constant curve, constant curve with external analogue signal, with the proportional differential pressure. The variable frequency drive guarantees energy savings and protection against water hammer. It must be mounted on the motor fan cover to take advantage of the cooling. It is possible to connect two MCE-C variable frequency drive together (through a special connection cable, supplied separately) for the creation of twin units. Compatibility with the DConnect service (DConnect Box supplied separately).

CME /CM-GE / DCME / DCM-GE

ELECTRONIC IN-LINE PUMPS FOR CIRCULATION SYSTEMS

MATERIALS

N.	PARTS	MATERIALS
1	PUMP BODY	CAST IRON 250 UNI ISO 185
3	SUPPORT	CAST IRON 250 UNI ISO 185
4	IMPELLER	CAST IRON 250 UNI ISO 185
7	SHAFT WITH ROTOR	AISI 303 STAINLESS STEEL X5 CrNiS 1809 UNI 6900/71
16	MECHANICAL SEAL	CARBON/GRAPHITE
28	OR RING	EPDM RUBBER

* In contact with the liquid

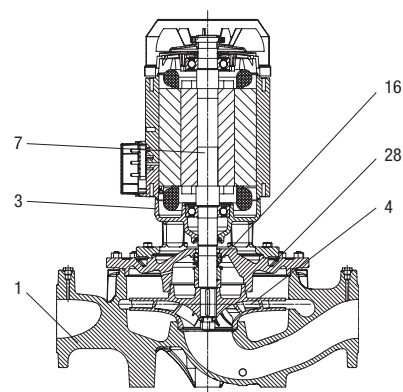

- Legend: (example)

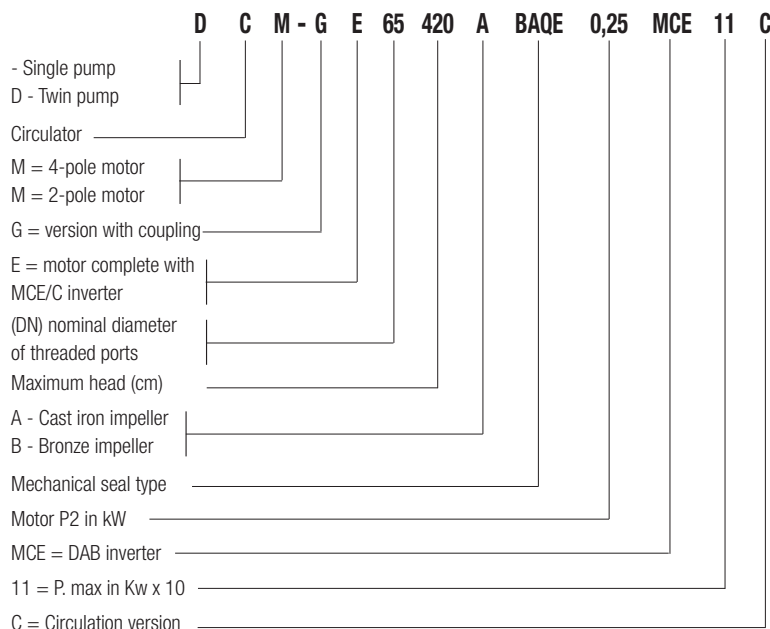

Installation: horizontal or vertical position, provided that the motor is always above the pump.

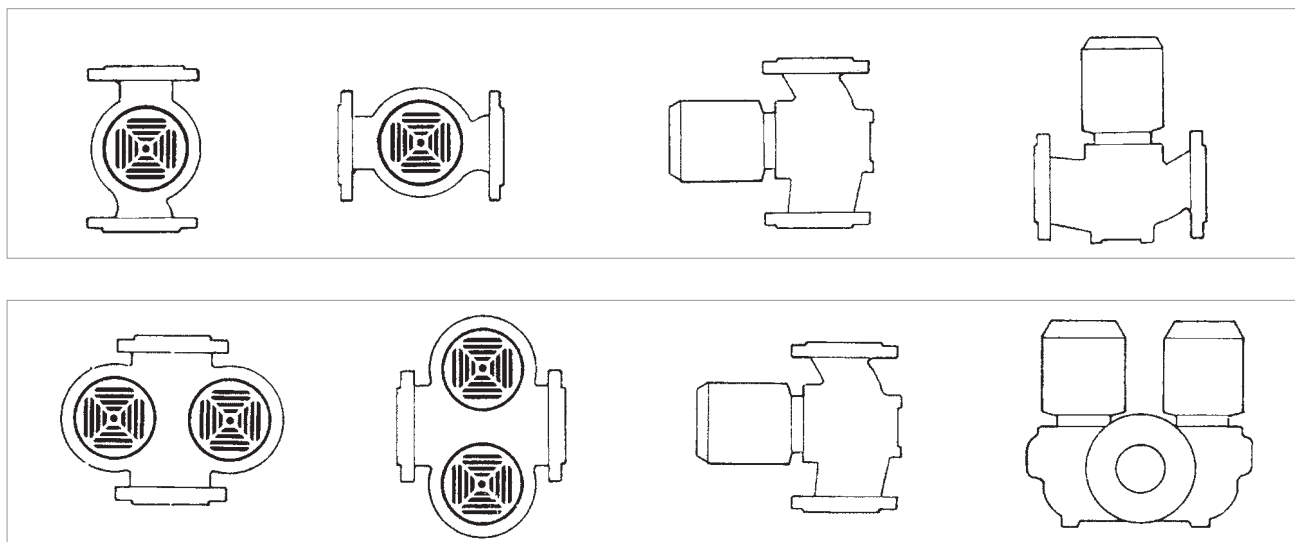

MCE/C INVERTER

MODES OF OPERATION

All the functions listed below can be consulted by the users (including less experienced ones) by simply scrolling through the MCE/C menu. The calibration and the modification of the parameters are protected, and can only be completed by expert users.

1 - ΔP -c constant differential pressure adjustment mode

The ΔP -c adjustment mode keeps the differential pressure of the system constantly at the H (setp) value set, even in case of variation of the flow rate. This is the standard adjustment used. It can be set directly from the MCE/C control panel. The inverter keeps the differential pressure (H setp) constant even in case of flow variation.

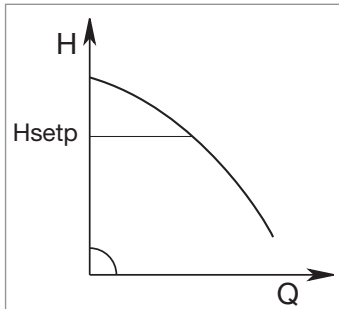

This adjustment is particularly indicated for the following systems:

- a. two-pipe heating systems with thermostat valves
- b. underfloor heating systems with thermostat valves
- c. single-pipe heating systems with thermostat valves and calibration valves
- d. systems with primary circuit pumps

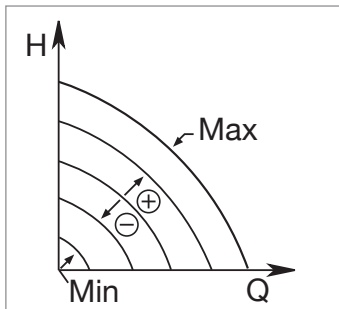

2 - Constant curve adjustment modes

2.1 - Constant curve adjustment

The rotation speed is kept at a constant number of revolutions. This rotation speed can be set between a minimum value and the nominal frequency of the circulation pump (e.g. between 15 Hz and 50 Hz). This mode can be set using the control panel on the MCE cover.

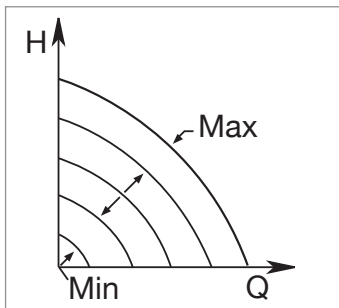

2.2 - Adjustment of the constant curve with external analogue signal

The rotation speed is kept at a constant number of revolution in proportion with the voltage of the external analogue signal.

The rotation speed changes in a linear way, between the nominal frequency of the pump when $V_{in} = 10$ V, and the minimum frequency when $V_{in} = 0$ V.

This mode can be set using the control panel on the MCE cover.

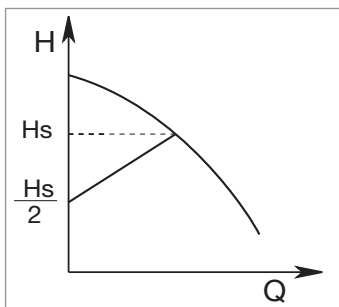

3 - ΔP -v * proportional differential pressure adjustment mode

With ΔP -v adjustment mode, with the variation of the flow rate, the value of the delivery of the head also varies in a linear manner, from Hsetp to Hsetp/2.

* in order to know the availability of the function on specific models contact our customer service.

For more information refer to the technical appendix.

ELECTRIC IN-LINE PUMPS

ELECTRONIC IN-LINE PUMPS FOR CIRCULATION SYSTEMS

PERFORMANCE RANGE

The performance curves are based on kinematic viscosity values = 1 mm²/s and density equal to 1000 kg/m³. Curve tolerance according to ISO 9906.

GRAPHIC SELECTION TABLE

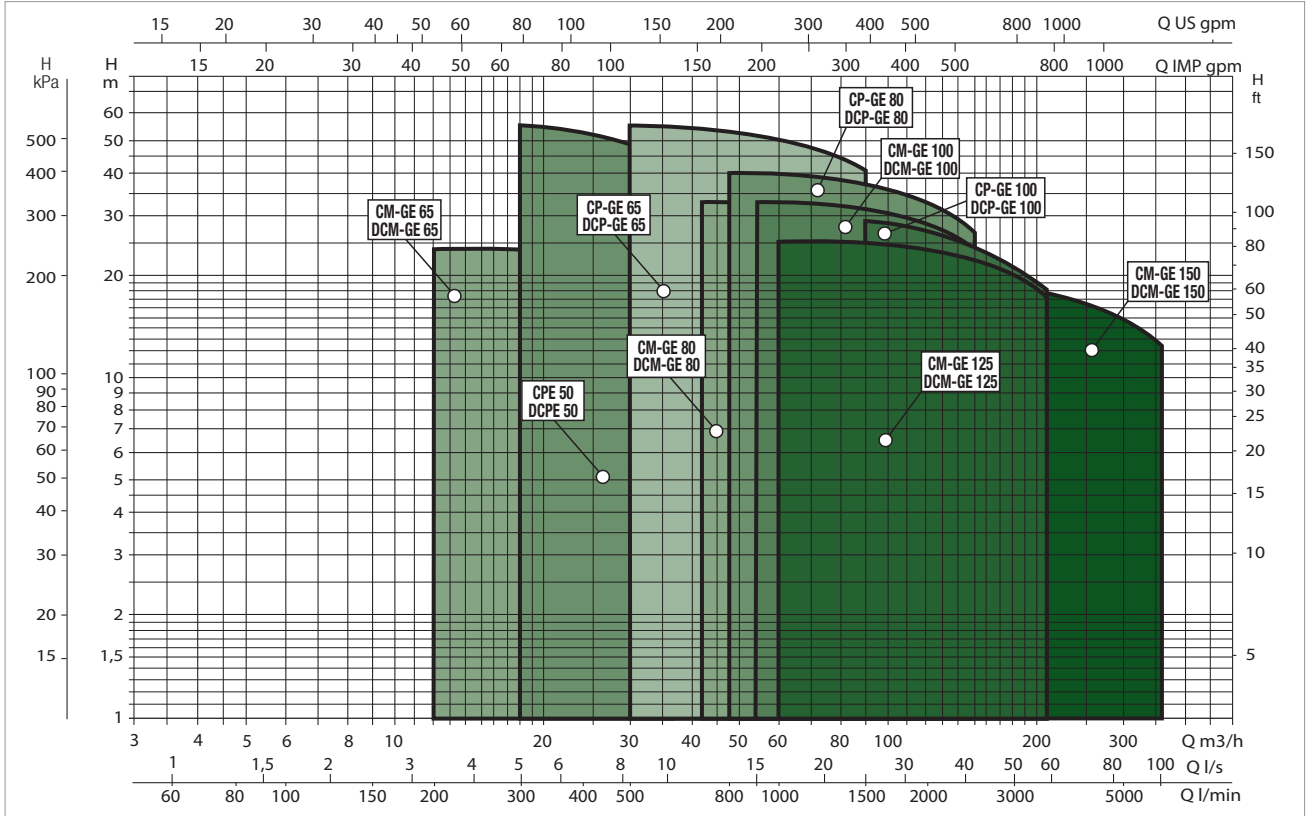

SELECTION TABLE - CME / CM-GE - 4 POLES

MODEL	P2 NOMINAL		Q= m ³ /h Q= l/min	0	1,2	2,4	3	3,6	4,5	4,8	6	12	18	24	30	36	42	48	54	
	kW	HP		0	20	40	50	60	75	80	100	200	300	400	500	600	700	800	900	
CM-GE 65-660	0,55	0,75	H (m)	6,6							6,5	6,2	5,7	4,8						
CM-GE 65-920	0,75	1		9,2								9,2	9	8,4	7,4	5,7				
CM-GE 65-1200	1,5	2		12									12	11,9	11,5	10,8	10,1	8,9		
CM-GE 65-1680	3	4		16,8									16,8	16,5	16,1	15,5	14,6	13,6	12,4	10,9
CM-GE 65-2380	4	5,5		23,8									24	23,8	23,4	22,7	21,6	20,4	19	17,1

CME /CM-GE / DCME / DCM-GE

ELECTRONIC IN-LINE PUMPS FOR CIRCULATION SYSTEMS

SELECTION TABLE - CME / CM-GE - 4 POLES

MODEL	P2 NOMINAL		Q= m³/h Q= l/min	0	12	18	24	30	36	42	48	54	60	66	72	78	84	90	102	114	
	kW	HP		0	200	300	400	500	600	700	800	900	1000	1100	1200	1300	1400	1500	1700	1900	
CM-GE 80-650	0,75	1	H (m)	6,5	6,3	6,1	5,8	5,5	5	4,5	3,9										
CM-GE 80-890	1,5	2		8,9		8,8	8,7	8,6	8,3	8	7,6	7,2	6,6	6							
CM-GE 80-1530	3	4		15,3			15,4	15,3	15	14,6	14,1	13,5	12,9	12,2	11,3						
CM-GE 80-1700	4	5,5		17			17,2	17,2	17,1	16,8	16,5	16,2	15,7	15,1	14,3	13,6	12,6				
CM-GE 80-2410	5,5	7,5		24,1			23,8	23,6	23,3	22,8	22,3	21,5	20,8	19,7	18,6	17,3					
CM-GE 80-2700	7,5	10		27						26	25,5	25	24,5	23,6	22,7	21,5	20,2	19			
CM-GE 80-3420	11	15		34,2							33,2	33	32,5	32	31,5	30,7	29,8	29	28	25	21,7

MODEL	P2 NOMINAL		Q= m³/h Q= l/min	0	12	18	24	30	36	42	48	54	60	66	72	78	84	90	102	114	120	150	180	210	240	250	270	330	360	
	kW	HP		0	200	300	400	500	600	700	800	900	1000	1100	1200	1300	1400	1500	1700	1900	2000	2500	3000	3500	4000	4167	4500	5500	6000	
CM-GE 100-510	0,75	1	H (m)	5,1	4,9	4,8	4,7	4,7	4,4	4,2	3,8	3,4	3																	
CM-GE 100-865	1,5	2		8,6				8,3	8,2	8,1	7,9	7,7	7,5	7,3	7,1	6,8	6,5	6,2	5,6	4,8										
CM-GE 100-1020	3	4		10,2				10,2	10,1	10	9,9	9,8	9,7	9,5	9,3	9	8,8	8,6	7,9	7,2	6,7									
CM-GE 100-1320	4	5,5		13,2					13,2	13,2	13,1	12,9	12,7	12,4	12	11,7	11,3	10,4	9,3	8,7										
CM-GE 100-1650	5,5	7,5		16,5					16,6	16,5	16,4	16,2	16,1	16	15,7	15,4	15	14,3	13,3	12,7										
CM-GE 100-2050	7,5	10		20,5					21	21	21	20,7	20,5	20	19,8	19,5	19	18	16,7	16										
CM-GE 100-2550	11	15		25,5					25,5	25,5	25,5	25,1	25	25	24,6	24,2	24	23	21,5	21										
CM-GE 100-3290	15	20		32,9							33,1	33	32,9	32,8	32,4	32	31,6	30,5	29,5	28,9	24									
CM-GE 125-1075	4	5,5		10,8								10,1	10,1	10	9,9	9,7	9,5	9,1	8,5	8,3	7	5,4								
CM-GE 125-1270	5,5	7,5		12,7								12,6	12,6	12,5	12,5	12,4	12,3	12	11,5	11,4	10,1	8,5								
CM-GE 125-1560	7,5	10		15,6								15,4	15,4	15,3	15,2	15,1	15	14,7	14,5	14,3	13,3	11,6	9,8							
CM-GE 125-2100	11	15		21								21,5	21,5	21,5	21,4	21,2	21	20,9	20	19,8	18	16								
CM-GE 125-2550	15	20		25,5								25,5	25,5	25,5	25,3	25,1	25,1	25	24,5	24	22,5	20,5	17,5							
CM-GE 150-955	5,5	7,5		9,6														9,6	9,5	9,4	9,3	8,7	7,8	6,7	5,9	5,5				
CM-GE 150-1322	7,5	10		13,2														13	12,8	12,6	12,5	11,9	11,1	10,1	8,9	8,5				
CM-GE 150-1600	11	15		16															15,5	15,5	15,4	14,8	14	13	11,8	11	10,5	9,2		
CM-GE 150-1950	15	20		19,5																19,5	19,4	19,3	19,2	18,7	17,8	16,8	16	15,5	14,1	12,5

CME /CM-GE / DCME / DCM-GE

ELECTRONIC IN-LINE PUMPS FOR CIRCULATION SYSTEMS

SELECTION TABLE - DCME / DCM-GE - 4 POLES

MODEL	P2 NOMINAL		Q= m³/h	0	3	4,5	6	12	18	24	30	36	42	48	54	60	66	72	78	84	90	102	114	120	150		
	kW	HP		Q= l/min	0	50	75	100	200	300	400	500	600	700	800	900	1000	1100	1200	1300	1400	1500	1700	1900	2000	2500	
DCM-GE 65-660	0,55	0,75	H (m)	6,5			6,4	5,9	4,4	3,1																	
DCM-GE 65-920	0,75	1		9,1			9,1	8,8	7,4	5,8	3,5																
DCM-GE 65-1200	1,5	2		12				11,9	11,6	11	10	9	7,6														
DCM-GE 65-1680	3	4		16,8				16,7	16,3	15,7	14,9	13,7	12,4	11	9,3												
DCM-GE 65-2380	4	5,5		23,8				23,9	23,5	22,8	21,8	20,3	18,6	16,8	14,5												
DCM-GE 80-650	0,75	1		6,5				6,2	5,8	5,2	4,5	3,7	2,9	2,1													
DCM-GE 80-890	1,5	2		8,5						8,3	8	7,5	6,8	6,1	5,3	4,4	3,5										
DCM-GE 80-1530	3	4		14,4						14,1	13,7	13	12,2	11,3	10,2	9,2	8	6,8									
DCM-GE 80-1700	4	5,5		16						15,7	15,5	15,3	14,6	14	13,2	12,3	11,2	10	8,9	7,7							
DCM-GE 80-2410	5,5	7,5		24,1								23,3	22,7	22	21,1	20,2	18,9	17,6	16,2								
DCM-GE 80-2700	7,5	10		27								26,1	26,1	25,5	24,9	24,2	23,2	22,1	20,7	19,3	17,9						
DCM-GE 80-3420	11	15		34,2								33,3	33,3	32,9	32,3	31,8	30,9	29,9	29	27,8	24,4	22	20,8				
DCM-GE 100-510	0,75	1		4,9				4,8	4,7	4,6	4,5	4	3,7	3,2	2,6	2,1											
DCM-GE 100-865	1,5	2		8,6							8,4	8,3	8,1	7,9	7,6	7,4	7,1	6,8	6,4	6	5,6	4,7	3,5				
DCM-GE 100-1020	3	4		10,2							10,2	10	9,8	9,6	9,5	9,3	8,9	8,5	8	7,5	7,1	5,9	4,7	4			
DCM-GE 100-1320	4	5,5		13,2									13,2	13,1	13	12,8	12,4	11,9	11,3	10,8	10,2	8,8	7,4	6,6			
DCM-GE 100-1650	5,5	7,5		16,5									16,5	16,4	16,3	16	15,8	15,5	14,9	14,4	13,7	12,4	10,8	10			
DCM-GE 100-2050	7,5	10		19,3												19,2	18,8	18,5	17,9	17,6	17,2	16,6	15,5	14,1	13,3		
DCM-GE 100-2550	11	15		24													23,3	22,8	22,6	22,4	21,9	21,4	21	19,8	18,1	17,5	
DCM-GE 100-3290	15	20		30,9														30,5	30,3	30,1	29,9	29,4	28,8	28,3	27	25,8	25,1

SELECTION TABLE - DCM-GE - 4 POLES

MODEL	P2 NOMINAL		Q= m³/h	0	60	66	72	78	84	90	102	114	120	150	180	210	240	250	270	330	360				
	kW	HP		Q= l/min	0	1000	1100	1200	1300	1400	1500	1700	1900	2000	2500	3000	3500	4000	4167	4500	5500	6000			
DCM-GE 125-1075	4	5,5	H (m)	10	9,5	9,4	9,2	9	8,7	8,4	7,7	6,8	6,5	4,4	2,4										
DCM-GE 125-1270	5,5	7,5		11,7	11,8	11,7	11,5	11,4	11,1	10,8	10,2	9,2	8,9	6,4	3,8										
DCM-GE 125-1560	7,5	10		14,4	14,6	14,6	14,4	14,2	14	13,8	13,2	12,7	12,3	10,2	7,5	4,9									
DCM-GE 125-2100	11	15		20,1						19,9	19,6	19,3	18,2	17,8	15,4	12,7									
DCM-GE 125-2550	15	20		24,5						23,8	23,7	23,4	22,7	22,1	20	17,4	13,9								
DCM-GE 150-955	5,5	7,5		9,6										8,1	7	6,2	4,9	3,5	2,8						
DCM-GE 150-1322	7,5	10		11,8							11,5	11,5	11,4	11	10	8,5	7,2	6	5,5						
DCM-GE 150-1600	11	15		14,8								14,2	14,2	14	13,4	12,5	11,4	10,1	9,4	8,8					
DCM-GE 150-1950	15	20		18,1									17,9	17,8	17,7	17,5	16,9	15,9	14,8	14	13,5	10,5	8,9		

CM-GE 65 4 POLES - ELECTRONIC IN-LINE PUMPS FOR CIRCULATION SYSTEMS

Pumped liquid temperature range: from -10 °C to +140°C - Maximum ambient temperature: +40°C

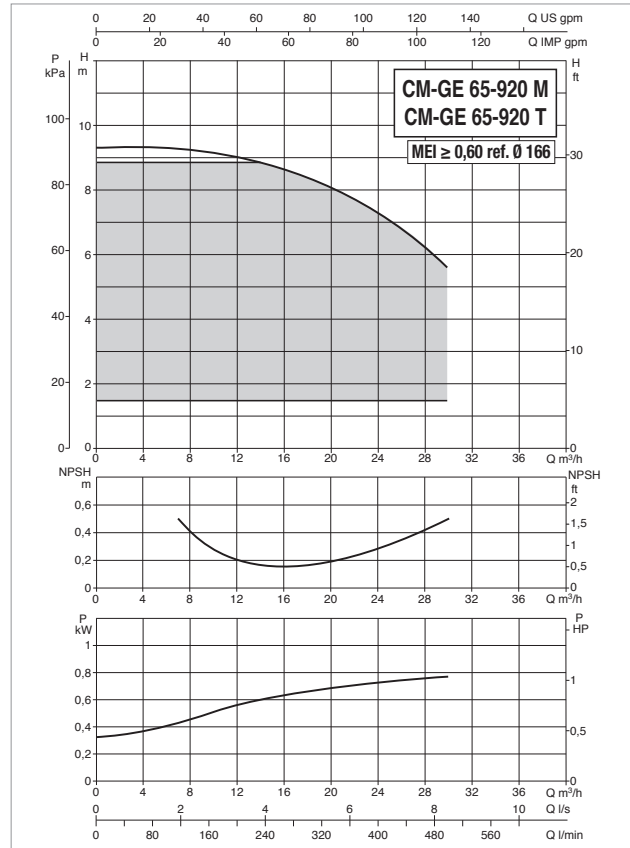
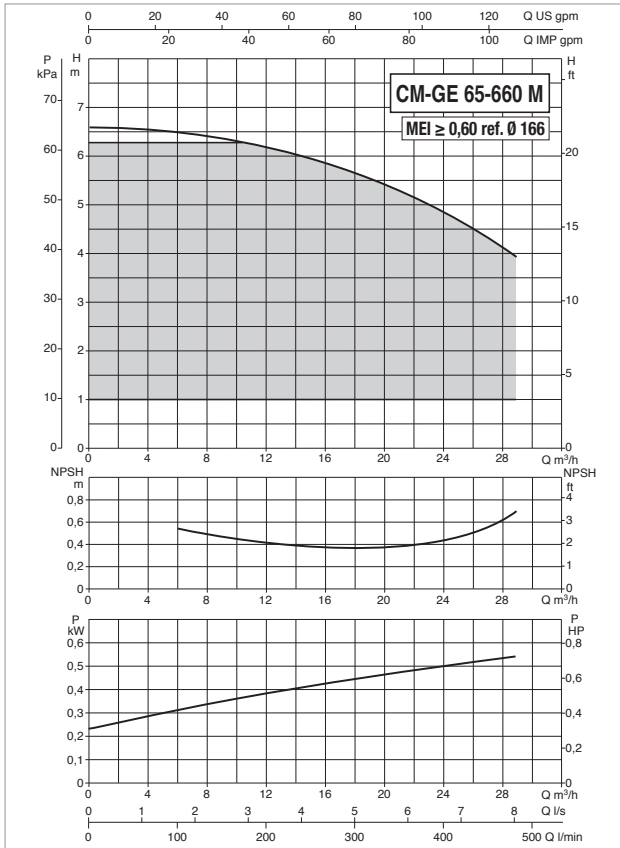

The MEI values for inverter controlled pumps refer to similar versions without electronics.

The performance curves are based on kinematic viscosity values = 1 mm²/s and density equal to 1000 kg/m³. Curve tolerance according to ISO 9906.

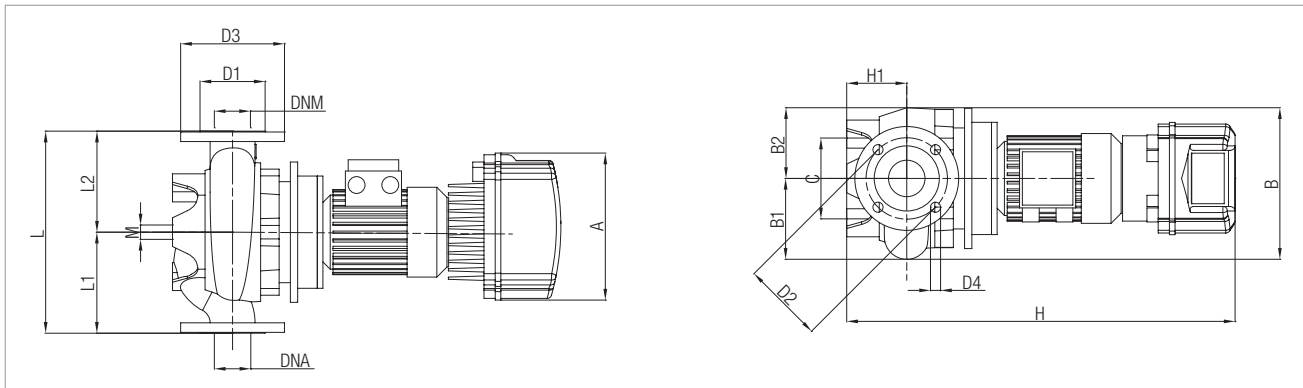

MODEL	ELECTRICAL DATA						
	POWER INPUT 50-60 Hz	POLES	n r.p.m.	P1 MAX kW	P2 NOMINAL		In A
					kW	HP	
CM-GE 65-660/A/BAQE/0,55 M MCE 11/C*	1 x 230v ~	4	1400	0,84	0,55	0,75	7,3
CM-GE 65-920/A/BAQE/0,75 M MCE 11/C*	1 x 230v ~	4	1430	1,23	0,75	1	9,8
CM-GE 65-920/A/BAQE/0,75 T MCE 30/C*	3 x 400 V ~	4	1430	1,23	0,75	1	1,8

* ΔP-v proportional differential pressure adjustment mode also available.

MODEL	A	B	B1	B2	B MAX	C	D	D1	D2	D3	D4	H	H1	H2	L	L1	L2	M	N	Y	DNA	DNM	PACKING DIMENSIONS			VOL. (m ³)	WEIGHT Kg
																							L/A	L/B	H		
CM-GE 65-660/A/BAQE/0,55 M MCE 11/C	262	270	144	126	-	144	-	122	145	185	4x18	713	105	-	360	180	180	16	-	-	65	65	650	400	945	0,25	62
CM-GE 65-920/A/BAQE/0,75 M MCE 11/C	262	270	144	126	-	144	-	122	145	185	4x18	713	105	-	360	180	180	16	-	-	65	65	650	400	945	0,25	64
CM-GE 65-920/A/BAQE/0,75 T MCE 30/C	262	270	144	126	-	144	-	122	145	185	4x18	713	105	-	360	180	180	16	-	-	65	65	650	400	945	0,25	64

CM-GE 65 4 POLES - ELECTRONIC IN-LINE PUMPS FOR CIRCULATION SYSTEMS

Pumped liquid temperature range: from -10 °C to +140°C - Maximum ambient temperature: +40°C

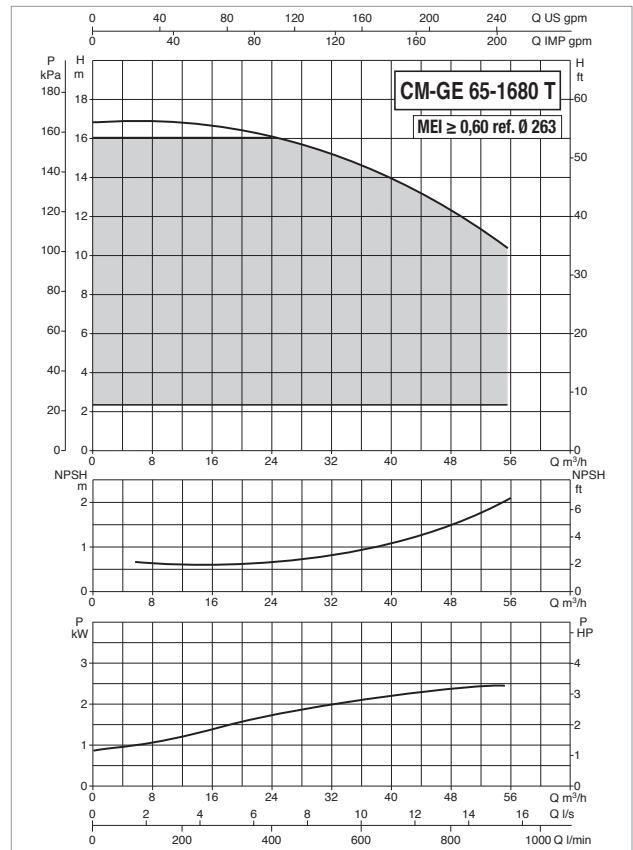
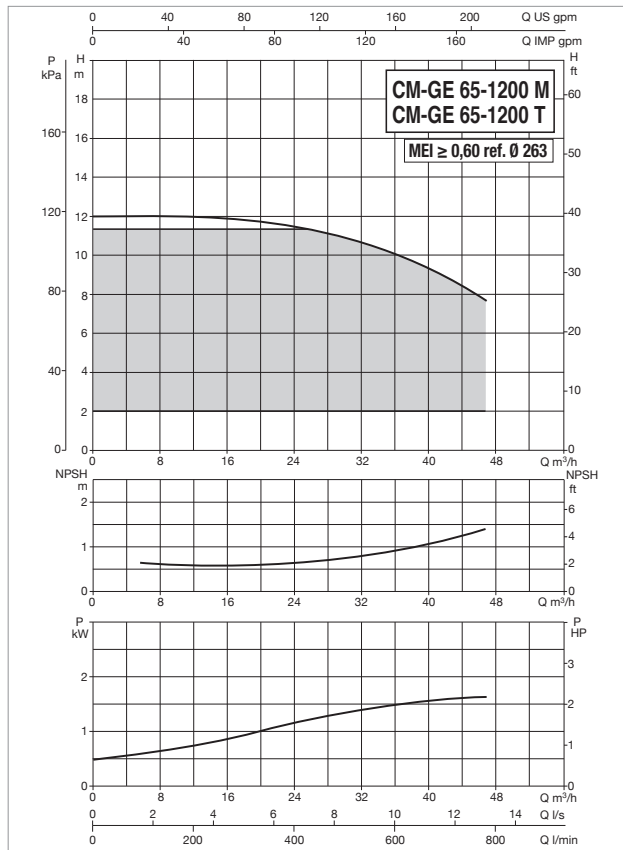

The MEI values for inverter controlled pumps refer to similar versions without electronics.

The performance curves are based on kinematic viscosity values = 1 mm²/s and density equal to 1000 kg/m³. Curve tolerance according to ISO 9906.

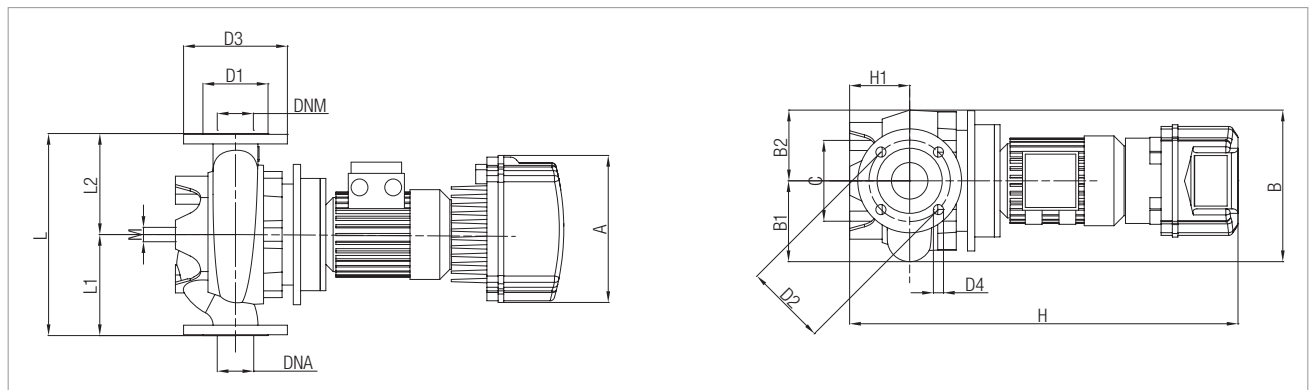

MODEL	ELECTRICAL DATA						
	POWER INPUT 50-60 Hz	POLES	n r.p.m.	P1 MAX kW	P2 NOMINAL		In A
					kW	HP	
CM-GE 65-1200/A/BAQE/1,5 T MCE 30/C*	3 x 400 V ~	4	1430	2,1	1,5	2	3,6
CM-GE 65-1200/A/BAQE/1,5 M MCE 11/C*	1 x 230 V ~	4	1430	1,87	1,5	2	13,9
CM-GE 65-1680/A/BAQE/3 T MCE 30/C*	3 x 400 V ~	4	1448	2,83	3	4	6,8

* ΔP-v proportional differential pressure adjustment mode also available.

MODEL	A	B	B1	B2	B MAX	C	D	D1	D2	D3	D4	H	H1	H2	L	L1	L2	M	N	Y	DNA	DNM	PACKING DIMENSIONS			VOL. (m ³)	WEIGHT Kg
	L/A	L/B	H																								
CM-GE 65-1200/A/BAQE/1,5 T MCE 30/C	262	344	180	164	-	144	-	122	145	185	4x18	764	125	-	475	237,5	237,5	16	-	-	65	65	650	400	945	0,25	91
CM-GE 65-1200/A/BAQE/1,5 M MCE 11/C	262	344	180	164	-	144	-	122	145	185	4x18	764	125	-	475	237,5	237,5	16	-	-	65	65	650	400	945	0,25	91
CM-GE 65-1680/A/BAQE/3 T MCE 30/C	353	344	180	164	-	144	-	122	145	185	4x18	821	125	-	475	237,5	237,5	16	-	-	65	65	650	400	945	0,25	101

CM-GE 65 4 POLES - ELECTRONIC IN-LINE PUMPS FOR CIRCULATION SYSTEMS

Pumped liquid temperature range: from -10 °C to +140°C - Maximum ambient temperature: +40°C

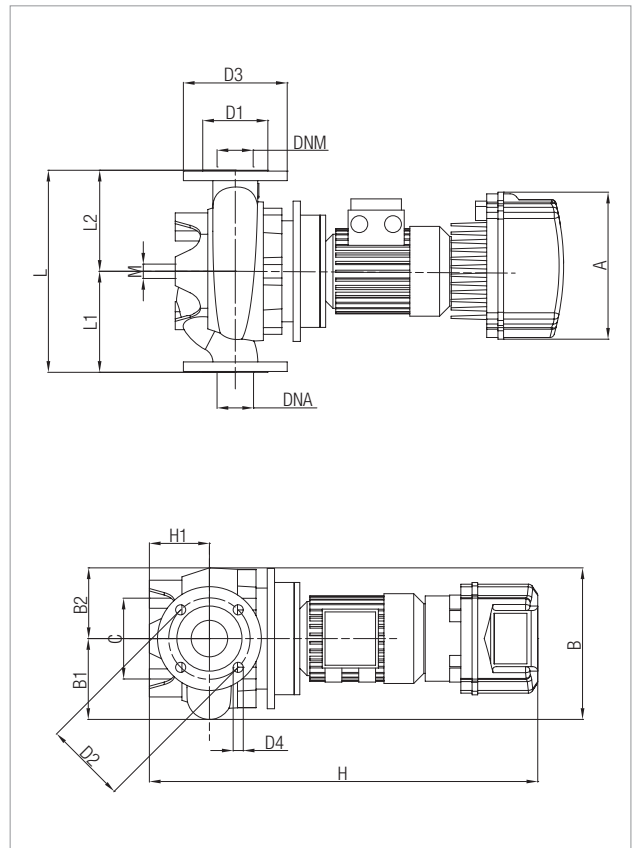
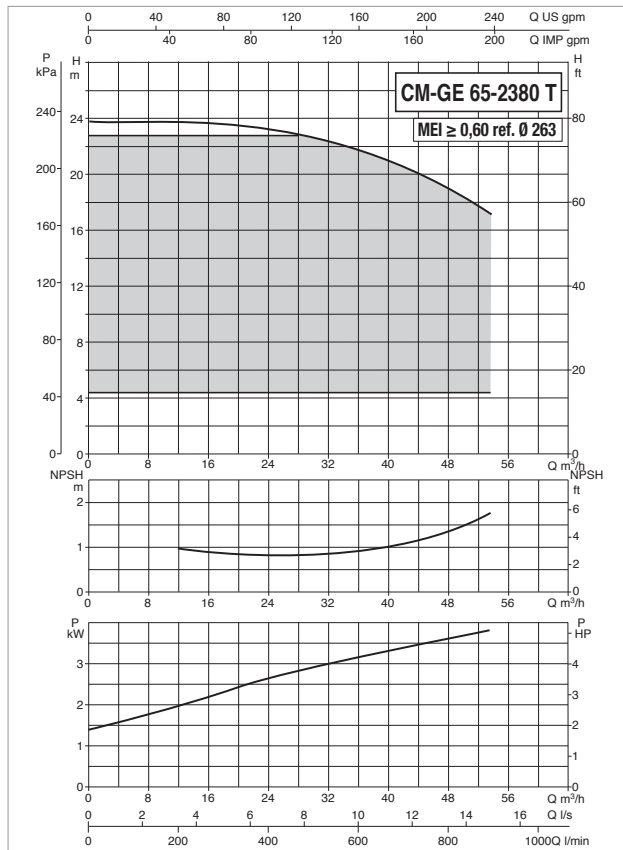

The MEI values for inverter controlled pumps refer to similar versions without electronics.

The performance curves are based on kinematic viscosity values = 1 mm²/s and density equal to 1000 kg/m³. Curve tolerance according to ISO 9906.

MODEL	ELECTRICAL DATA						
	POWER INPUT 50-60 Hz	POLES	n r.p.m.	P1 MAX kW	P2 NOMINAL		In A
					kW	HP	
CM-GE 65-2380/A/BAQE/4 T MCE 55/C*	3 x 400 V ~	4	1449	4,47	4	5,5	8,2

* ΔP-v proportional differential pressure adjustment mode also available.

MODEL	A	B	B1	B2	B MAX	C	D	D1	D2	D3	D4	H	H1	H2	L	L1	L2	M	N	Y	DNA	DNM	PACKING DIMENSIONS			VOL. (m ³)	WEIGHT Kg
	L/A	L/B	H																								
CM-GE 65-2380/A/BAQE/4 T MCE 55/C	353	344	180	164	-	144	-	122	145	185	4x18	821	125	-	475	237,5	237,5	16	-	-	65	65	650	400	945	0,25	115

CM-GE 80 4 POLES - ELECTRONIC IN-LINE PUMPS FOR CIRCULATION SYSTEMS

Pumped liquid temperature range: from -10 °C to +140°C - Maximum ambient temperature: +40°C

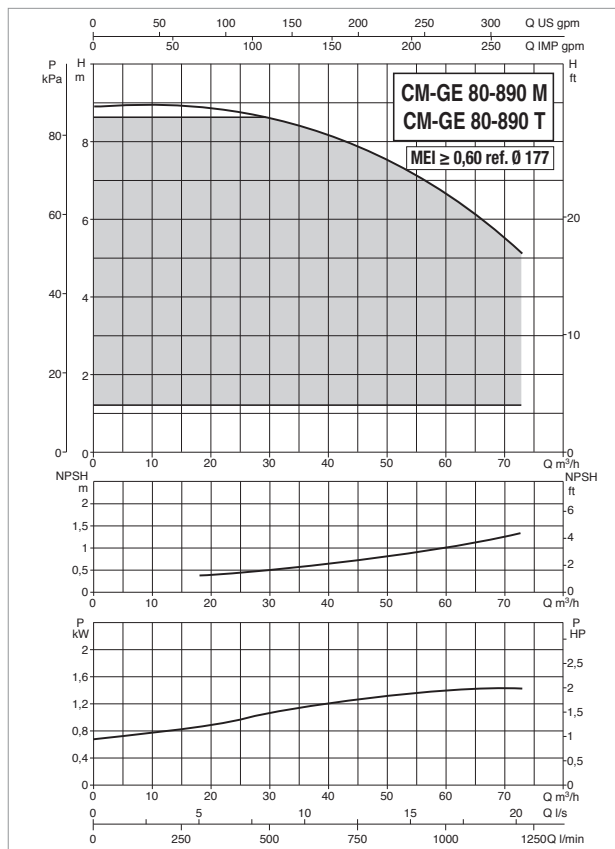
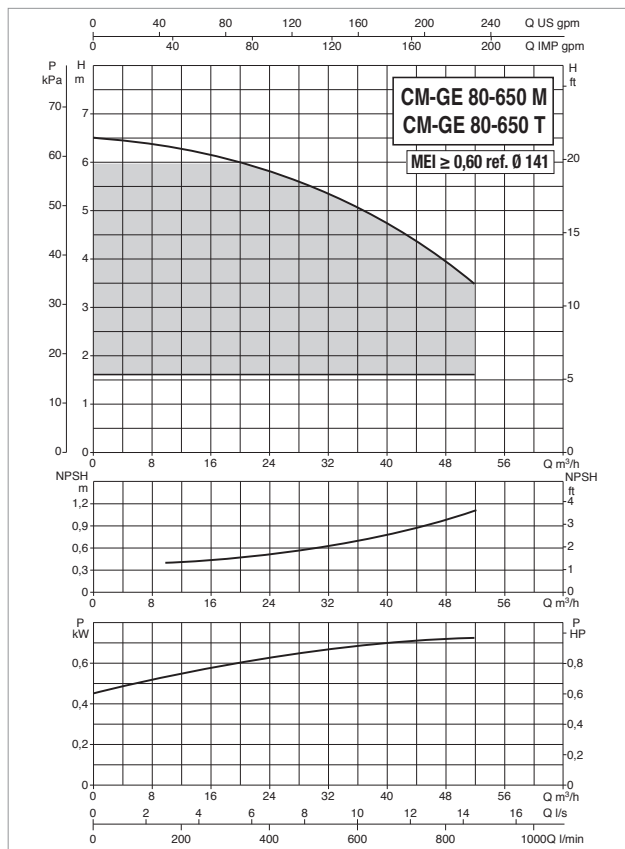

The MEI values for inverter controlled pumps refer to similar versions without electronics.

The performance curves are based on kinematic viscosity values = 1 mm²/s and density equal to 1000 kg/m³. Curve tolerance according to ISO 9906.

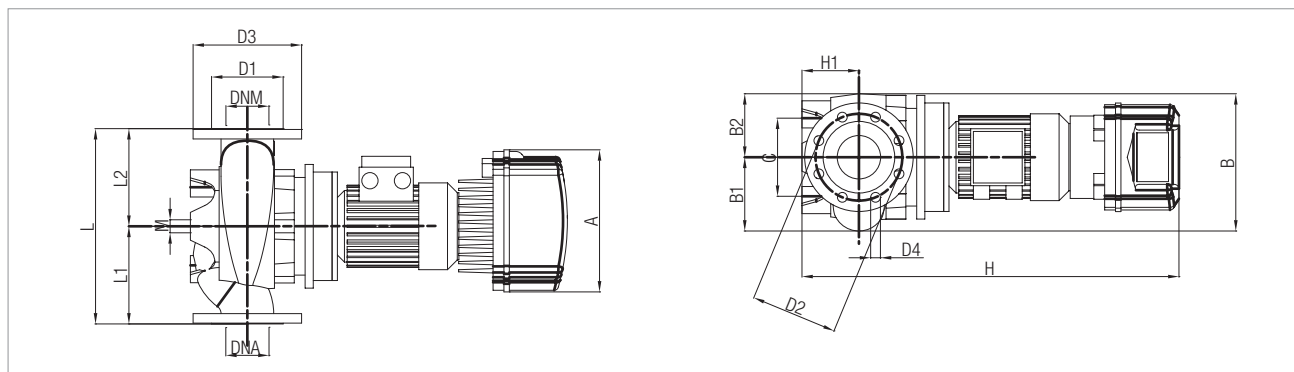

MODEL	ELECTRICAL DATA						
	POWER INPUT 50-60 Hz	POLES	n r.p.m.	P1 MAX kW	P2 NOMINAL		In A
					kW	HP	
CM-GE 80-650/A/BAQE/0,75 M MCE 11/C*	1 x 230 V ~	4	1430	1,24	0,75	1	9,8
CM-GE 80-650/A/BAQE/0,75 T MCE 30/C	3 x 400 V ~	4	1430	1,24	0,75	1	1,8
CM-GE 80-890/A/BAQE/1,5 T MCE 30/C*	3 x 400 V ~	4	1430	2,07	1,5	2	3,6
CM-GE 80-890/A/BAQE/1,5 M MCE 11/C*	1 x 230 V ~	4	1430	1,87	1,5	2	13,9

* ΔP-v proportional differential pressure adjustment mode also available.

MODEL	A	B	B1	B2	B MAX	C	D	D1	D2	D3	D4	H	H1	H2	L	L1	L2	M	N	Y	DNA	DNM	PACKING DIMENSIONS			VOL. (m ³)	WEIGHT Kg
																							L/A	L/B	H		
CM-GE 80-650/A/BAQE/0,75 M MCE 11/C	262	252	135	117	-	144	-	138	160	200	8x18	716	105	-	360	180	180	16	-	-	80	80	650	400	945	0,25	67
CM-GE 80-650/A/BAQE/0,75 T MCE 30/C	262	252	135	117	-	144	-	138	160	200	8x18	716	105	-	360	180	180	16	-	-	80	80	650	400	945	0,25	69,6
CM-GE 80-890/A/BAQE/1,5 T MCE 30/C	262	324	178	146	-	144	-	138	160	200	8x18	765	115	-	440	220	220	16	-	-	80	80	650	400	945	0,25	98
CM-GE 80-890/A/BAQE/1,5 M MCE 11/C	262	324	178	146	-	144	-	138	160	200	8x18	765	115	-	440	220	220	16	-	-	80	80	650	400	945	0,25	98

CM-GE 80 4 POLES - ELECTRONIC IN-LINE PUMPS FOR CIRCULATION SYSTEMS

Pumped liquid temperature range: from -10 °C to +140°C - Maximum ambient temperature: +40°C

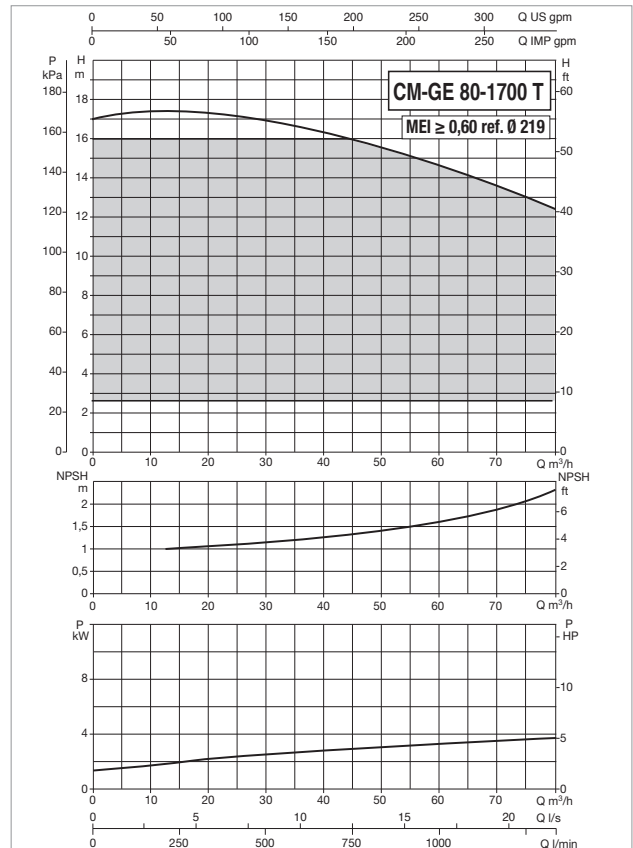
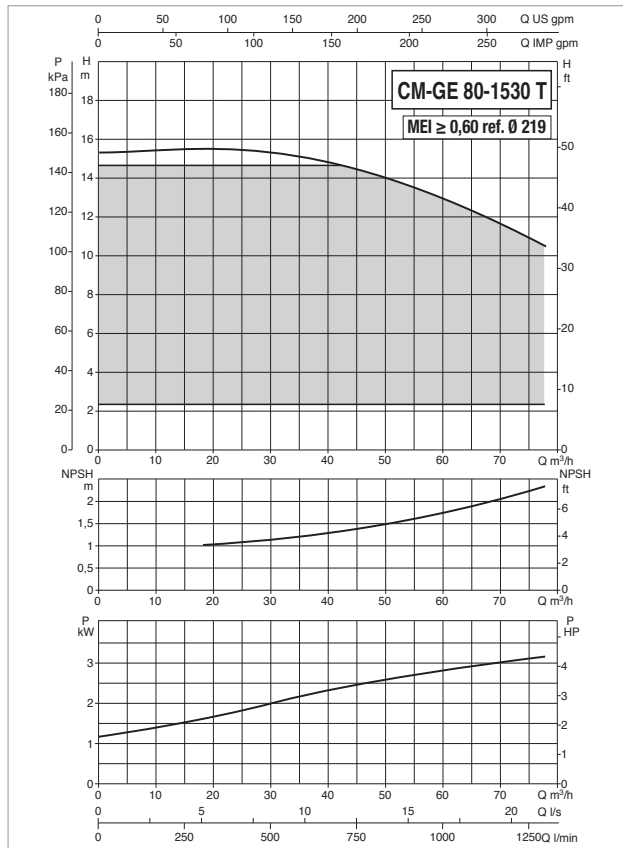

The MEI values for inverter controlled pumps refer to similar versions without electronics.

The performance curves are based on kinematic viscosity values = 1 mm²/s and density equal to 1000 kg/m³. Curve tolerance according to ISO 9906.

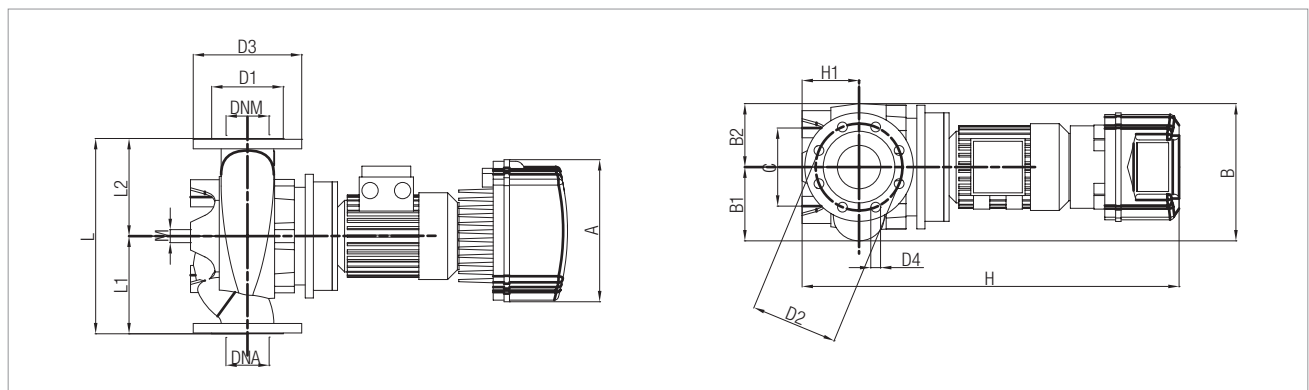

MODEL	ELECTRICAL DATA						
	POWER INPUT 50-60 Hz	POLES	n r.p.m.	P1 MAX kW	P2 NOMINAL		In A
					kW	HP	
CM-GE 80-1530/A/BAQE/3 T MCE 30/C*	3 x 400 V ~	4	1441	3,74	3	4	6,8
CM-GE 80-1700/A/BAQE/4 T MCE 55/C*	3 x 400 V ~	4	1452	4,13	4	5,5	8,2

* ΔP-v proportional differential pressure adjustment mode also available.

MODEL	A	B	B1	B2	B MAX	C	D	D1	D2	D3	D4	H	H1	H2	L	L1	L2	M	N	Y	DNA	DNM	PACKING DIMENSIONS			VOL. (m ³)	WEIGHT Kg
	L/A	L/B	H	L/A	L/B	H	L/A	L/B	H																		
CM-GE 80-1530/A/BAQE/3 T MCE 30/C	353	354	190	164	-	144	-	138	160	200	8x18	822	115	-	500	250	250	16	-	-	80	80	650	400	945	0,25	134
CM-GE 80-1700/A/BAQE/4 T MCE 55/C	353	354	190	164	-	144	-	138	160	200	8x18	822	115	-	500	250	250	16	-	-	80	80	650	400	945	0,25	147

CM-GE 80 4 POLES - ELECTRONIC IN-LINE PUMPS FOR CIRCULATION SYSTEMS

Pumped liquid temperature range: from -10 °C to +140°C - Maximum ambient temperature: +40°C

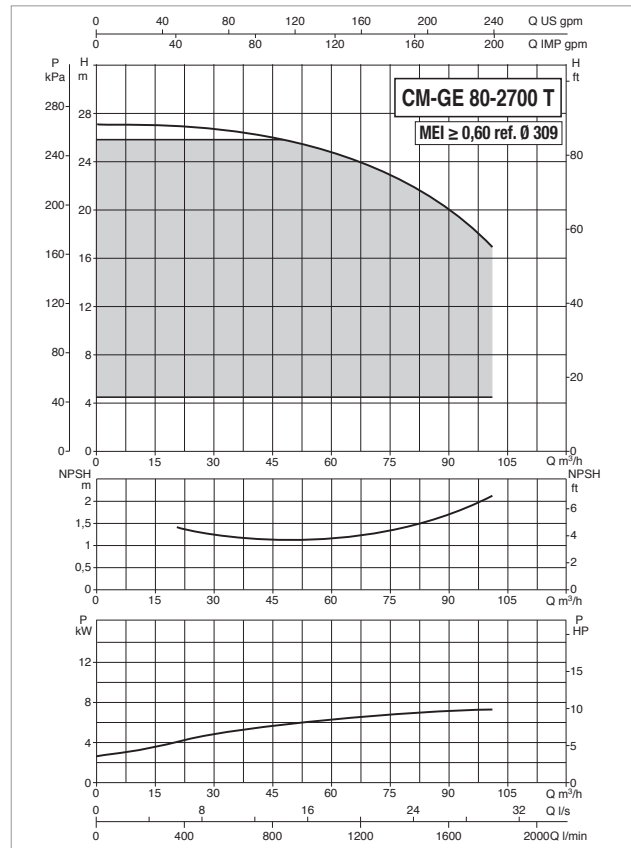
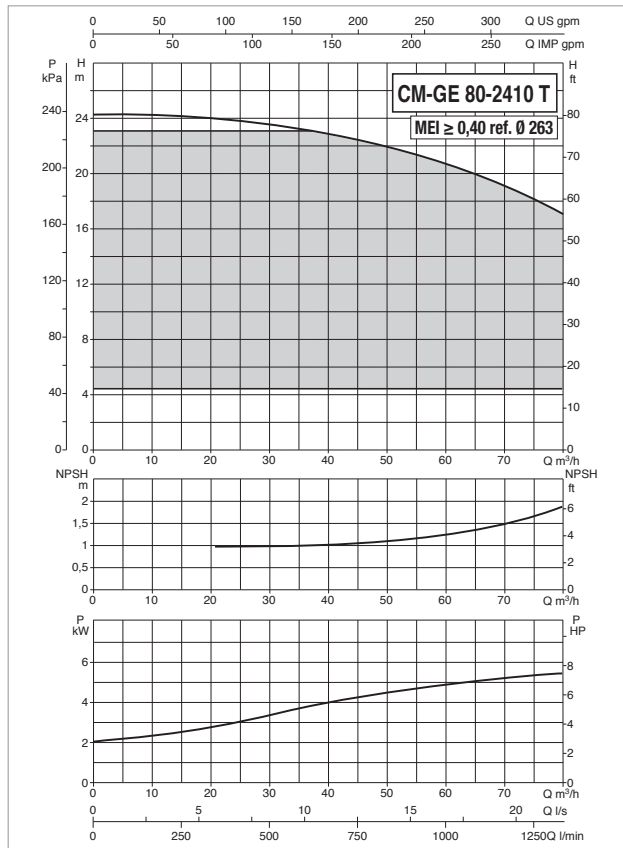

The MEI values for inverter controlled pumps refer to similar versions without electronics.

The performance curves are based on kinematic viscosity values = 1 mm²/s and density equal to 1000 kg/m³. Curve tolerance according to ISO 9906.

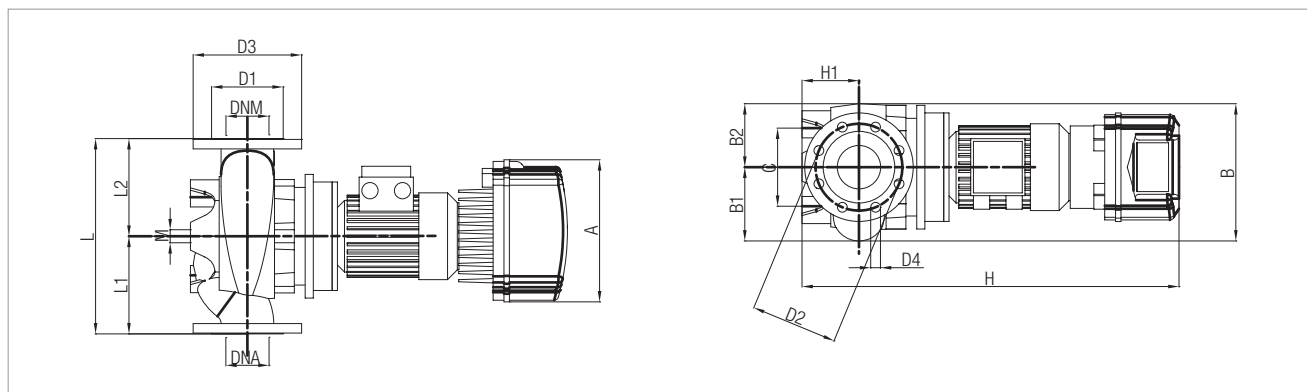

MODEL	ELECTRICAL DATA						
	POWER INPUT 50-60 Hz	POLES	n r.p.m.	P1 MAX kW	P2 NOMINAL		In A
					kW	HP	
CM-GE 80-2410/A/BAQE/5,5 T MCE 55/C*	3 x 400 V ~	4	1461	6,8	5,5	7,5	10,6
CM-GE 80-2700/A/BAQE/7,5 T MCE 110/C	3 x 400 V ~	4	1463	9,15	7,5	10	14,4

* ΔP-v proportional differential pressure adjustment mode also available.

MODEL	A	B	B1	B2	B MAX	C	D	D1	D2	D3	D4	H	H1	H2	L	L1	L2	M	N	Y	DNA	DNM	PACKING DIMENSIONS			VOL. (m ³)	WEIGHT Kg
	L/A	L/B	H	L/A	L/B	H																					
CM-GE 80-2410/A/BAQE/5,5 T MCE 55/C	353	469	245	224	-	230	-	138	160	200	8x18	1067	140	-	620	310	310	16	-	-	80	80	700	600	600	0,25	175
CM-GE 80-2700/A/BAQE/7,5 T MCE 110/C	426	469	245	224	-	230	-	138	160	200	8x18	1115	140	-	620	310	310	16	-	-	80	80	700	600	1220	0,51	205

CM-GE 80 4 POLES - ELECTRONIC IN-LINE PUMPS FOR CIRCULATION SYSTEMS

Pumped liquid temperature range: from -10 °C to +140°C - Maximum ambient temperature: +40°C

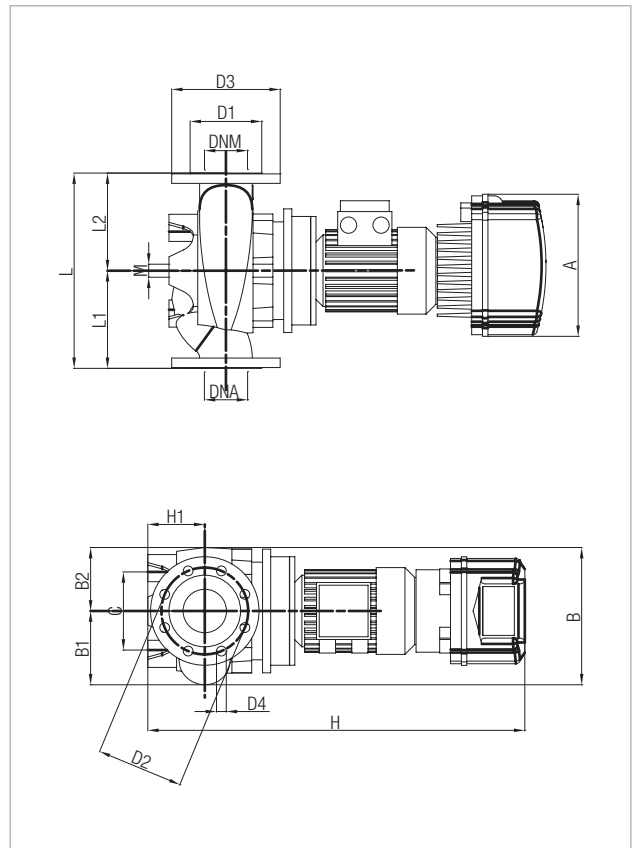
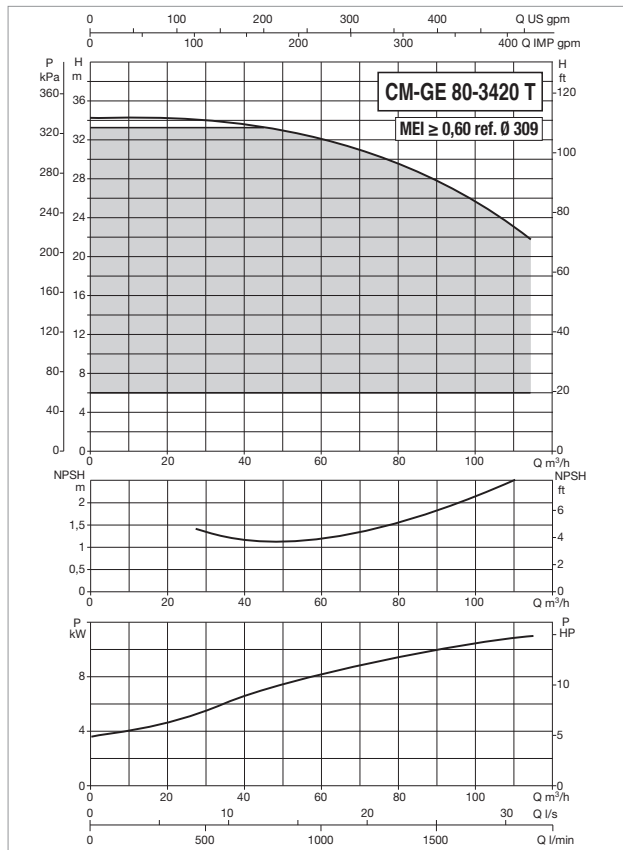

The MEI values for inverter controlled pumps refer to similar versions without electronics.

The performance curves are based on kinematic viscosity values = 1 mm²/s and density equal to 1000 kg/m³. Curve tolerance according to ISO 9906.

MODEL	ELECTRICAL DATA						
	POWER INPUT 50-60 Hz	POLES	n r.p.m.	P1 MAX kW	P2 NOMINAL		In A
					kW	HP	
CM-GE 80-3420/A/BAQE/11 T MCE 110/C*	3 x 400 V ~	4	1472	13,36	11	15	22,4

* ΔP-v proportional differential pressure adjustment mode also available.

MODEL	A	B	B1	B2	B MAX	C	D	D1	D2	D3	D4	H	H1	H2	L	L1	L2	M	N	Y	DNA	DNM	PACKING DIMENSIONS			VOL. (m ³)	WEIGHT Kg
	L/A	L/B	H																								
CM-GE 80-3420/A/BAQE/11 T MCE 110/C	426	469	245	224	-	230	-	138	160	200	8x18	1115	140	-	620	310	310	16	-	-	80	80	700	600	1220	0,51	222

CM-GE 100 4 POLES - ELECTRONIC IN-LINE PUMPS FOR CIRCULATION SYSTEMS

Pumped liquid temperature range: from -10 °C to +140°C - Maximum ambient temperature: +40°C

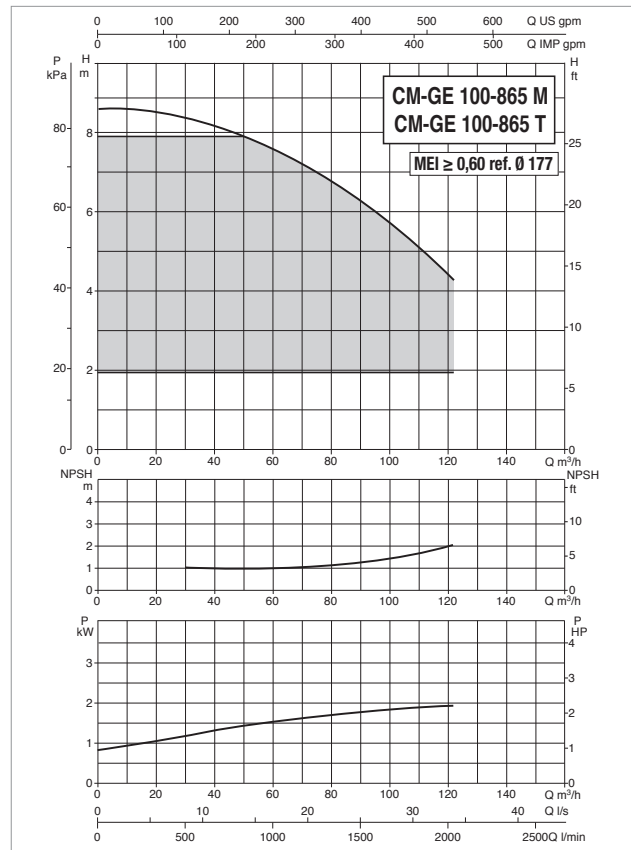
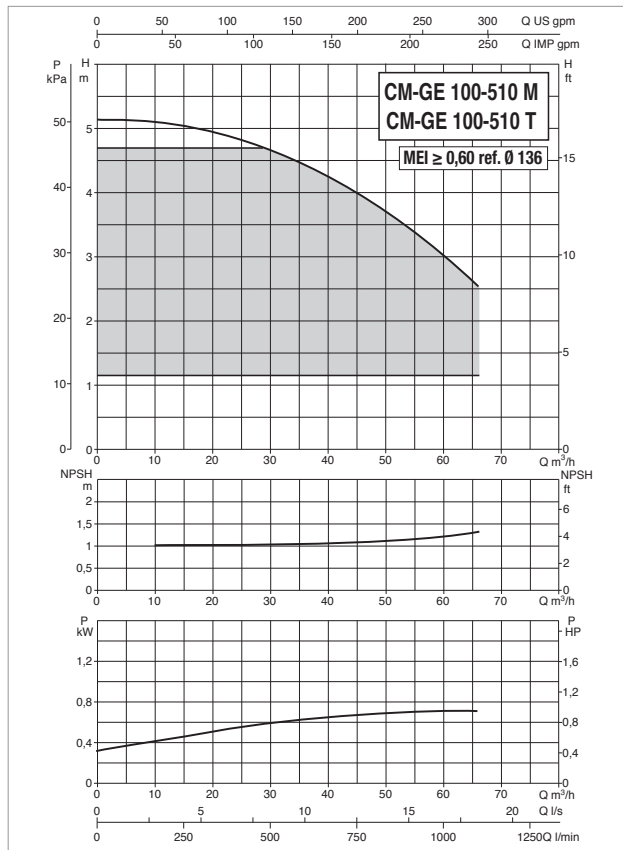

The MEI values for inverter controlled pumps refer to similar versions without electronics.

The performance curves are based on kinematic viscosity values = 1 mm²/s and density equal to 1000 kg/m³. Curve tolerance according to ISO 9906.

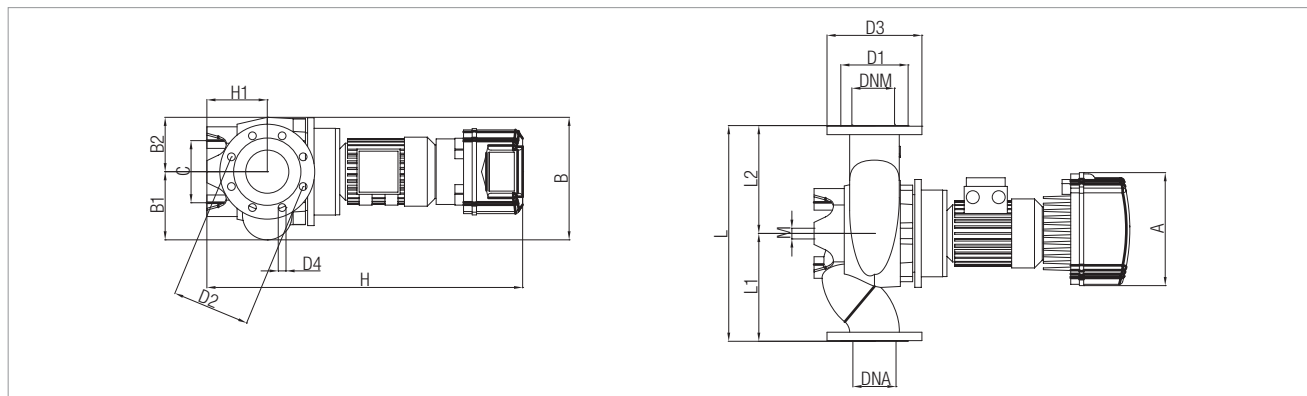

MODEL	ELECTRICAL DATA						
	POWER INPUT 50-60 Hz	POLES	n r.p.m.	P1 MAX kW	P2 NOMINAL		In A
					kW	HP	
CM-GE 100-510/A/BAQE/0,75 M MCE 11/C*	1 x 230 V ~	4	1430	1,21	0,75	1	9,7
CM-GE 100-510/A/BAQE/0,75 T MCE 30/C	3 x 400 V ~	4	1430	1,21	0,75	1	1,8
CM-GE 100-865/A/BAQE/1,5 M MCE 22/C*	1 x 230 V ~	4	1438	2,94	1,5	2	20,7
CM-GE 100-865/A/BAQE/2,2 T MCE 30/C*	3 x 400 V ~	4	1438	2,94	2,2	3	5,9

* ΔP-v proportional differential pressure adjustment mode also available.

MODEL	A	B	B1	B2	B MAX	C	D	D1	D2	D3	D4	H	H1	H2	L	L1	L2	M	N	Y	DNA	DNM	PACKING DIMENSIONS			VOL. (m ³)	WEIGHT Kg
																							L/A	L/B	H		
CM-GE 100-510/A/BAQE/0,75 M MCE 11/C	262	284	158	126	-	144	-	158	180	220	8x18	753	140	-	500	250	250	16	-	-	100	100	650	400	945	0,25	104
CM-GE 100-510/A/BAQE/0,75 T MCE 30/C	262	284	158	126	-	144	-	158	180	220	8x18	753	140	-	500	250	250	16	-	-	100	100	650	400	945	0,25	106,6
CM-GE 100-865/A/BAQE/2,2 M MCE 22/C	262	215	192	152	-	230	-	158	180	220	8x19	865	140	-	550	275	275	16	-	-	100	100	650	400	945	0,25	123
CM-GE 100-865/A/BAQE/2,2 T MCE 30/C	353	215	192	152	-	230	-	158	180	220	8x20	862	140	-	550	275	275	16	-	-	100	100	650	400	945	0,25	126

CM-GE 100 4 POLES - ELECTRONIC IN-LINE PUMPS FOR CIRCULATION SYSTEMS

Pumped liquid temperature range: from -10 °C to +140°C - Maximum ambient temperature: +40°C

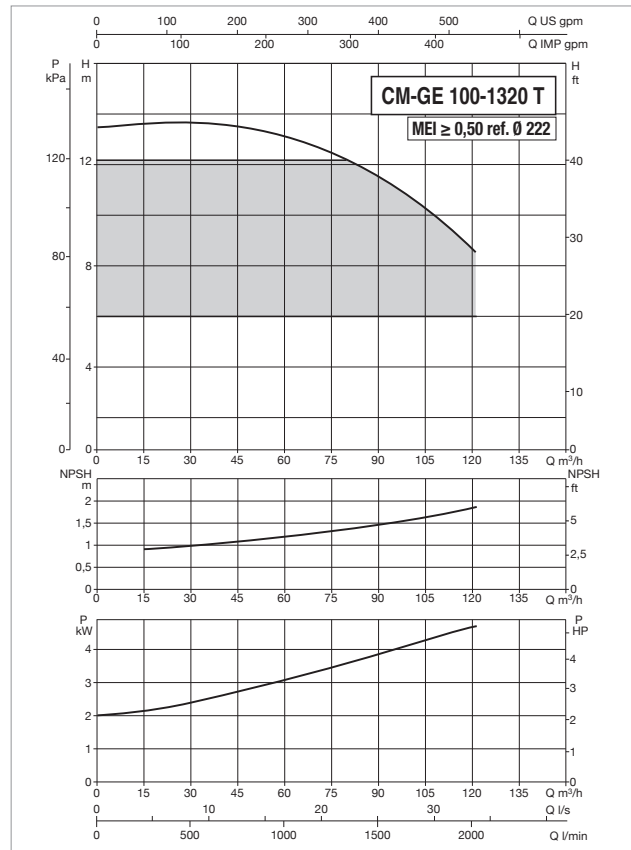
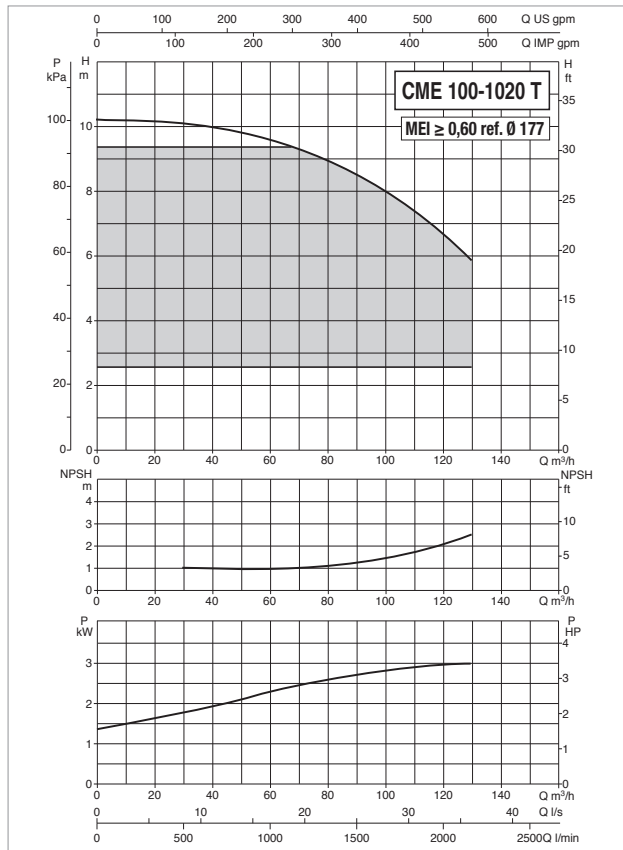

The MEI values for inverter controlled pumps refer to similar versions without electronics.

The performance curves are based on kinematic viscosity values = 1 mm²/s and density equal to 1000 kg/m³. Curve tolerance according to ISO 9906.

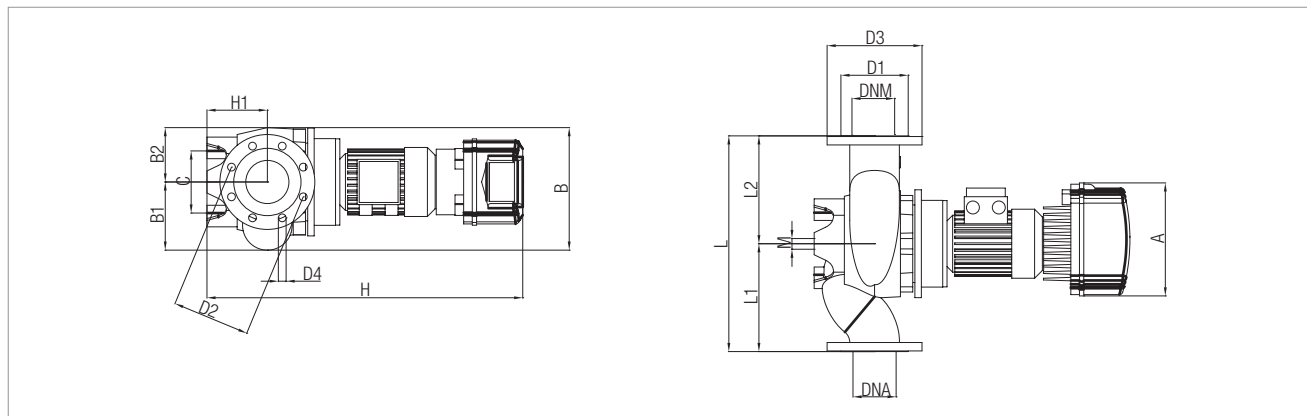

MODEL	ELECTRICAL DATA						
	POWER INPUT 50-60 Hz	POLES	n r.p.m.	P1 MAX kW	P2 NOMINAL		In A
					kW	HP	
CM-GE 100-1020/A/BAQE/3 T MCE 30/C*	3 x 400 V ~	4	1441	3,77	3	4	6,8
CM-GE 100-1320/A/BAQE/4 T MCE 55/C*	3 x 400 V ~	4	1450	4,81	4	5,5	8,2

* ΔP-v proportional differential pressure adjustment mode also available.

MODEL	A	B	B1	B2	B MAX	C	D	D1	D2	D3	D4	H	H1	H2	L	L1	L2	M	N	Y	DNA	DNM	PACKING DIMENSIONS			VOL. (m ³)	WEIGHT Kg
																							L/A	L/B	H		
																							CM-GE 100-1020/A/BAQE/3 T MCE 30/C	353	346		
CM-GE 100-1320/A/BAQE/4 T MCE 55/C	353	378	204	174	-	230	-	158	180	220	8x18	881	140	-	550	275	275	16	-	-	100	100	650	400	945	0,25	150

CM-GE 100 4 POLES - ELECTRONIC IN-LINE PUMPS FOR CIRCULATION SYSTEMS

Pumped liquid temperature range: from -10 °C to +140°C - Maximum ambient temperature: +40°C

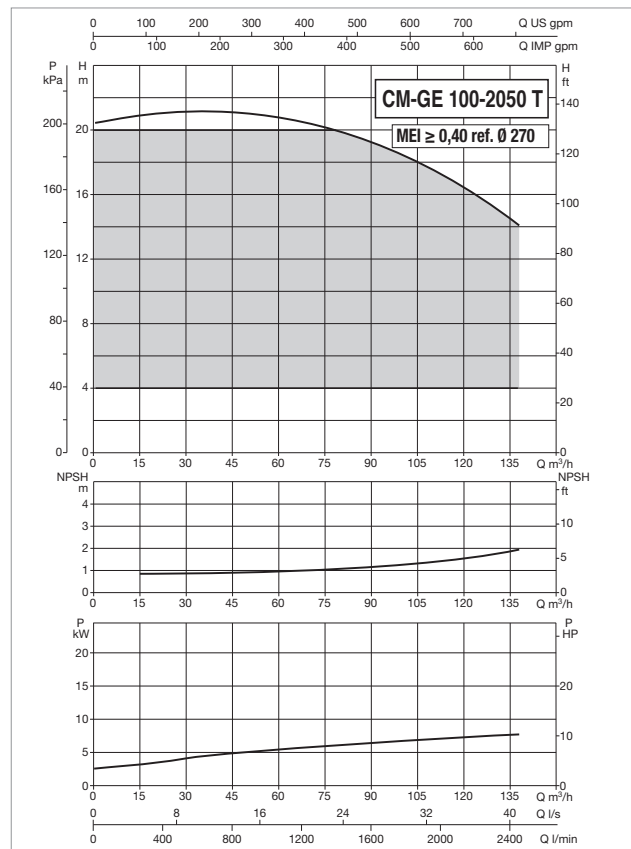
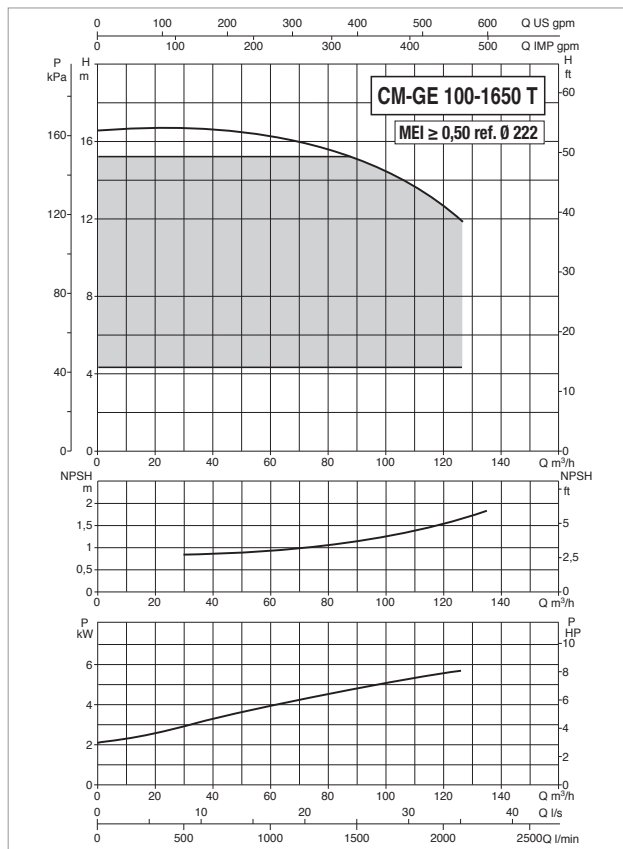

The MEI values for inverter controlled pumps refer to similar versions without electronics.

The performance curves are based on kinematic viscosity values = 1 mm²/s and density equal to 1000 kg/m³. Curve tolerance according to ISO 9906.

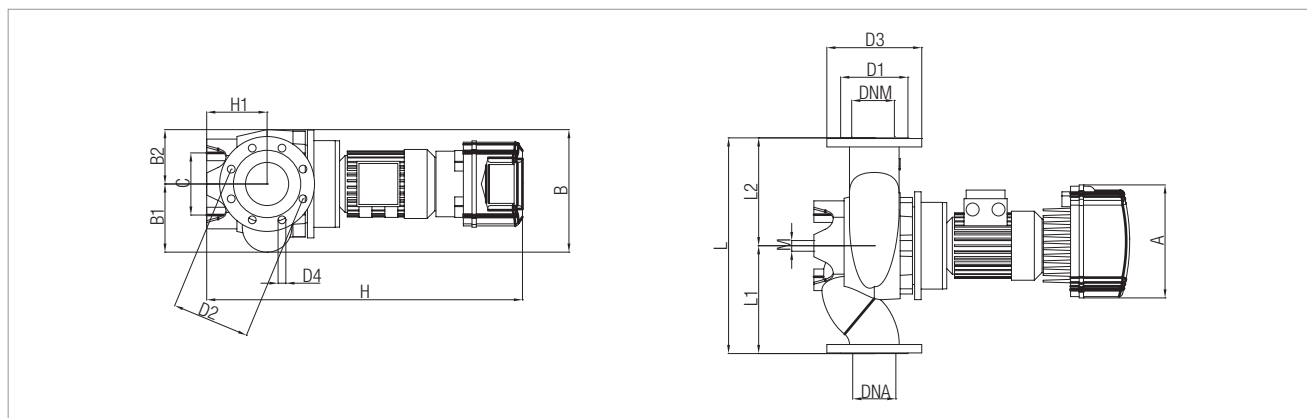

MODEL	ELECTRICAL DATA						
	POWER INPUT 50-60 Hz	POLES	n r.p.m.	P1 MAX kW	P2 NOMINAL		In A
					kW	HP	
CM-GE 100-1650/A/BAQE/5,5 T MCE 55/C*	3 x 400 V ~	4	1464	7,27	5,5	7,5	10,6
CM-GE 100-2050/A/BAQE/7,5 T MCE 110/C	3 x 400 V ~	4	1461	8,89	7,5	10	14,4

* ΔP-v proportional differential pressure adjustment mode also available.

MODEL	A	B	B1	B2	B MAX	C	D	D1	D2	D3	D4	H	H1	H2	L	L1	L2	M	N	Y	DNA	DNM	PACKING DIMENSIONS			VOL. (m ³)	WEIGHT Kg
																							L/A	L/B	H		
CM-GE 100-1650/A/BAQE/5,5 T MCE 55/C	353	378	204	174	-	230	-	158	180	220	8x18	1021	140	-	550	275	275	16	-	-	100	100	650	400	945	0,25	172
CM-GE 100-2050/A/BAQE/7,5 T MCE 110/C	426	545	293	252	-	230	-	158	180	220	8x18	1155	175	-	670	335	335	16	-	-	100	100	700	600	1220	0,51	252

CM-GE 100 4 POLES - ELECTRONIC IN-LINE PUMPS FOR CIRCULATION SYSTEMS

Pumped liquid temperature range: from -10 °C to +140°C - Maximum ambient temperature: +40°C

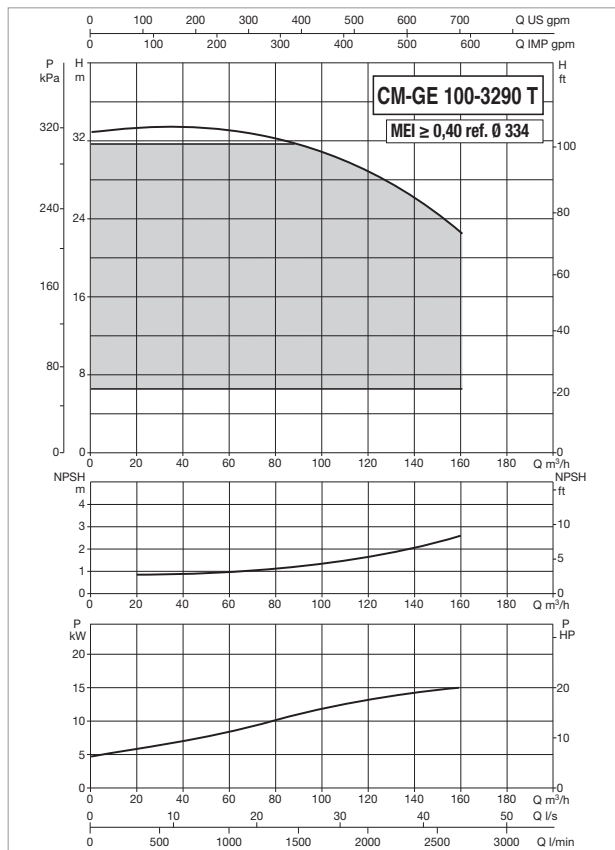
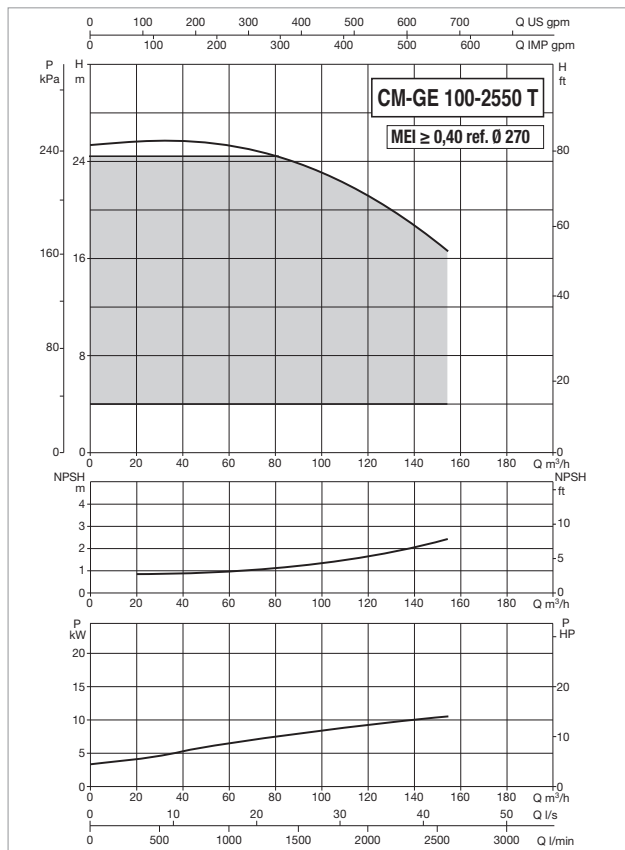

The MEI values for inverter controlled pumps refer to similar versions without electronics.

The performance curves are based on kinematic viscosity values = 1 mm²/s and density equal to 1000 kg/m³. Curve tolerance according to ISO 9906.

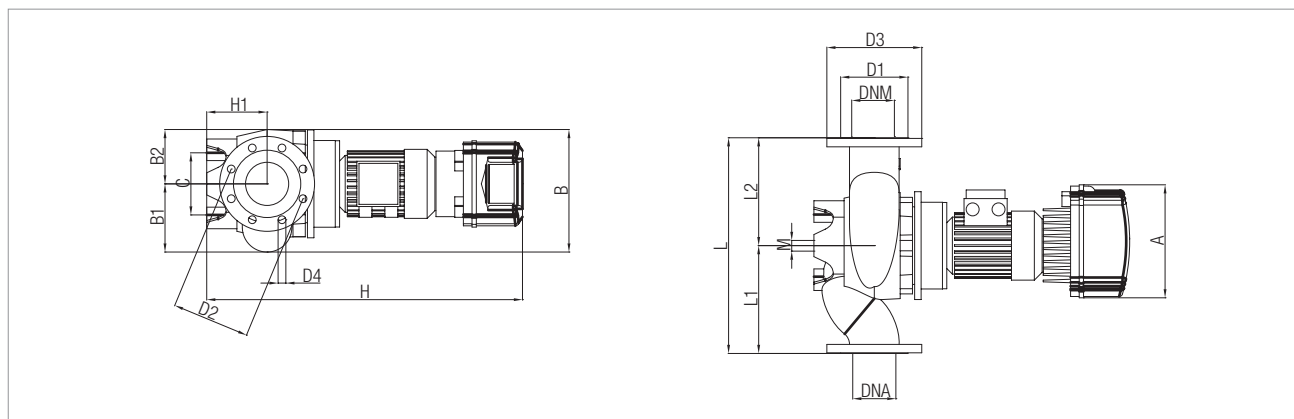

MODEL	ELECTRICAL DATA						
	POWER INPUT 50-60 Hz	POLES	n r.p.m.	P1 MAX kW	P2 NOMINAL		In A
					kW	HP	
CM-GE 100-2550/A/BAQE/11 T MCE 110/C*	3 x 400 V ~	4	1470	12,74	11	15	22,4
CM-GE 100-3290/A/BAQE/15 T MCE 150/C*	3 x 400 V ~	4	1471	17,91	15	20	30,5

* ΔP-v proportional differential pressure adjustment mode also available.

MODEL	A	B	B1	B2	B MAX	C	D	D1	D2	D3	D4	H	H1	H2	L	L1	L2	M	N	Y	DNA	DNM	PACKING DIMENSIONS			VOL. (m ³)	WEIGHT Kg
																							L/A	L/B	H		
CM-GE 100-2550/A/BAQE/11 T MCE 110/C	426	545	293	252	-	230	-	158	180	220	8x18	1155	175	-	670	335	335	16	-	-	100	100	700	600	1220	0,51	255
CM-GE 100-3290/A/BAQE/15 T MCE 150/C	426	545	293	252	-	230	-	158	180	220	8x18	1357	175	-	670	335	335	16	-	-	100	100	900	550	1200	0,59	350

CM-GE 125 4 POLES - ELECTRONIC IN-LINE PUMPS FOR CIRCULATION SYSTEMS

Pumped liquid temperature range: from -10 °C to +140°C - Maximum ambient temperature: +40°C

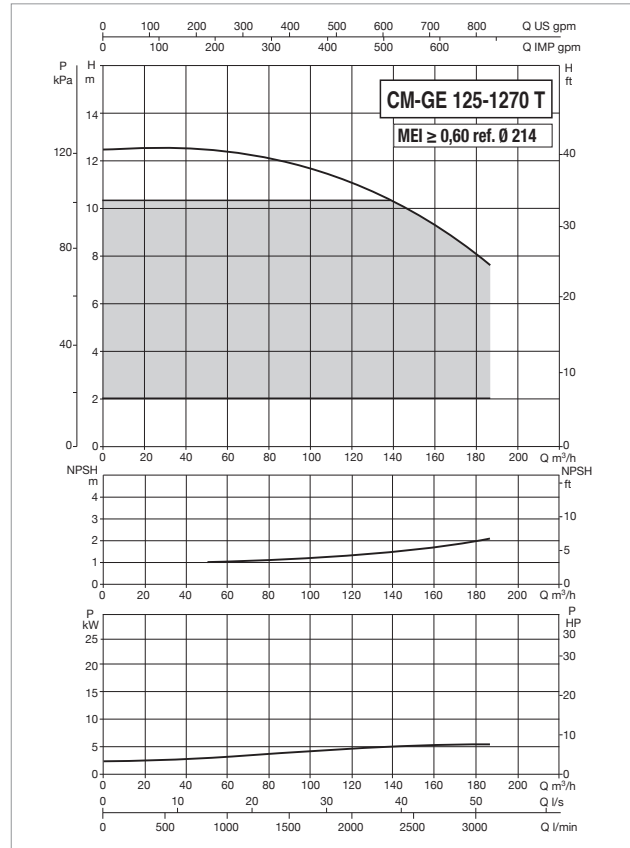
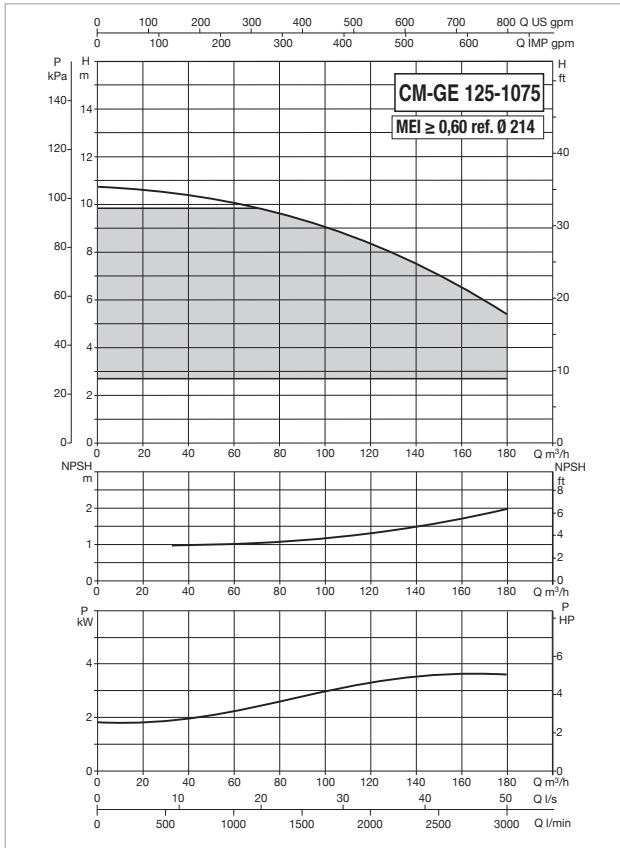

The MEI values for inverter controlled pumps refer to similar versions without electronics.

The performance curves are based on kinematic viscosity values = 1 mm²/s and density equal to 1000 kg/m³. Curve tolerance according to ISO 9906.

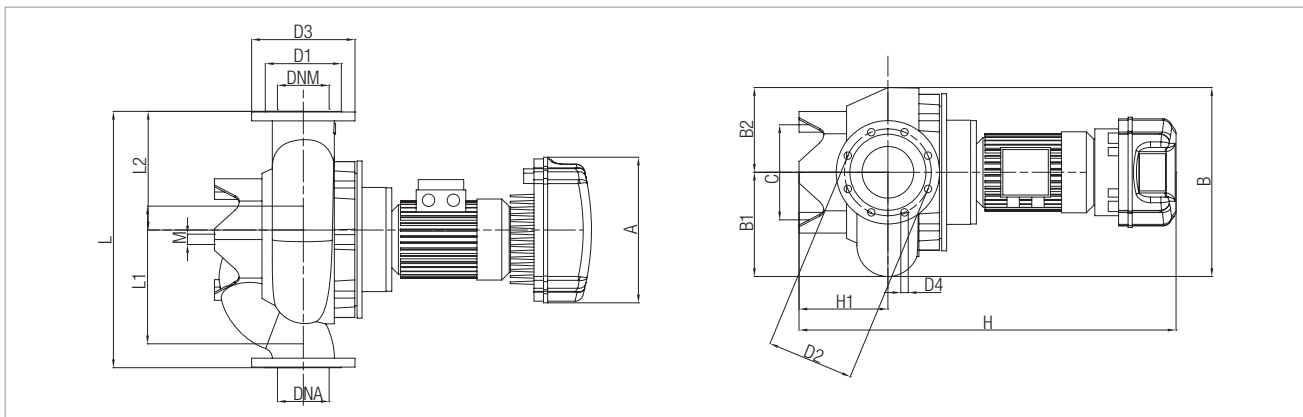

MODEL	ELECTRICAL DATA						
	POWER INPUT 50-60 Hz	POLES	n r.p.m.	P1 MAX kW	P2 NOMINAL		In A
					kW	HP	
CM-GE 125-1075/A/BAQE/4 T MCE 55/C*	3 x 400 V ~	4	1455	5,38	4	5,5	8,2
CM-GE 125-1270/A/BAQE/5,5 T MCE 55/C*	3 x 400 V ~	4	1465	7,55	5,5	7,5	10,6

* ΔP-v proportional differential pressure adjustment mode also available.

MODEL	A	B	B1	B2	B MAX	C	D	D1	D2	D3	D4	H	H1	H2	L	L1	L2	M	N	Y	DNA	DNM	PACKING DIMENSIONS			VOL. (m ³)	WEIGHT Kg
																							L/A	L/B	H		
CM-GE 125-1075/A/BAQE/4 T MCE 55/C	353	457	252	205	-	230	-	188	210	250	8x18	962	215	-	620	310	310	16	-	-	125	125	700	600	1220	0,51	207
CM-GE 125-1270/A/BAQE/5,5 T MCE 55/C	353	457	252	205	-	230	-	188	210	250	8x18	1101	215	-	620	310	310	16	-	-	125	125	700	600	1220	0,51	209

CM-GE 125 4 POLES - ELECTRONIC IN-LINE PUMPS FOR CIRCULATION SYSTEMS

Pumped liquid temperature range: from -10 °C to +140°C - Maximum ambient temperature: +40°C

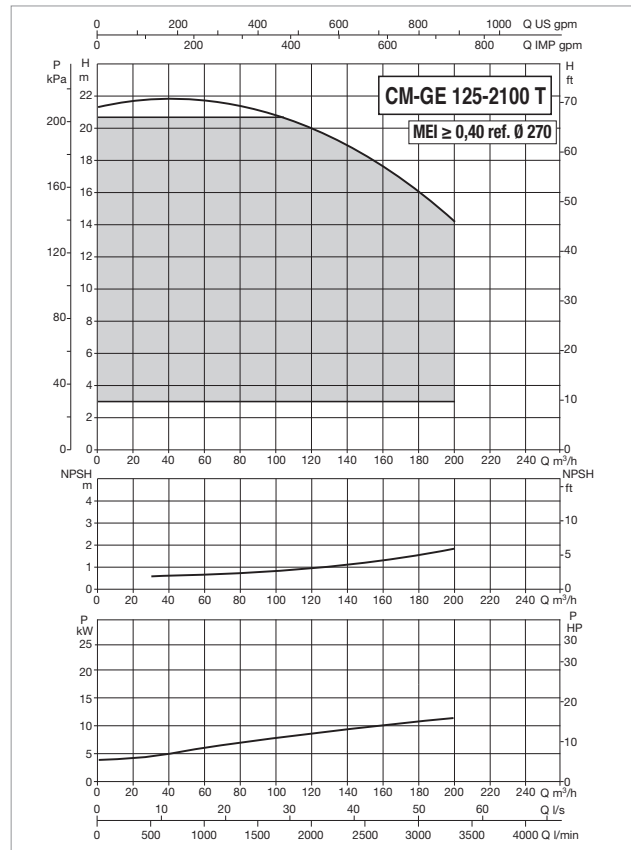
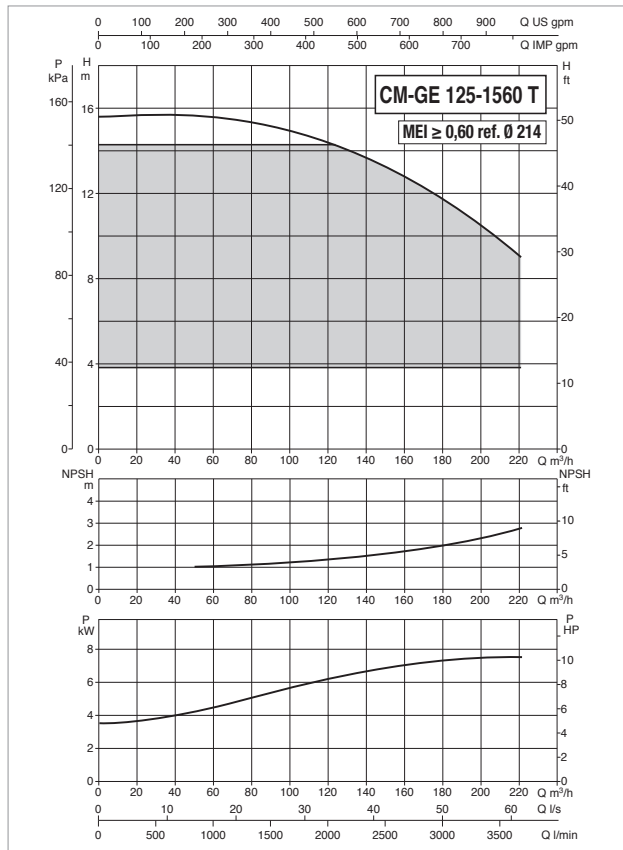

The MEI values for inverter controlled pumps refer to similar versions without electronics.

The performance curves are based on kinematic viscosity values = 1 mm²/s and density equal to 1000 kg/m³. Curve tolerance according to ISO 9906.

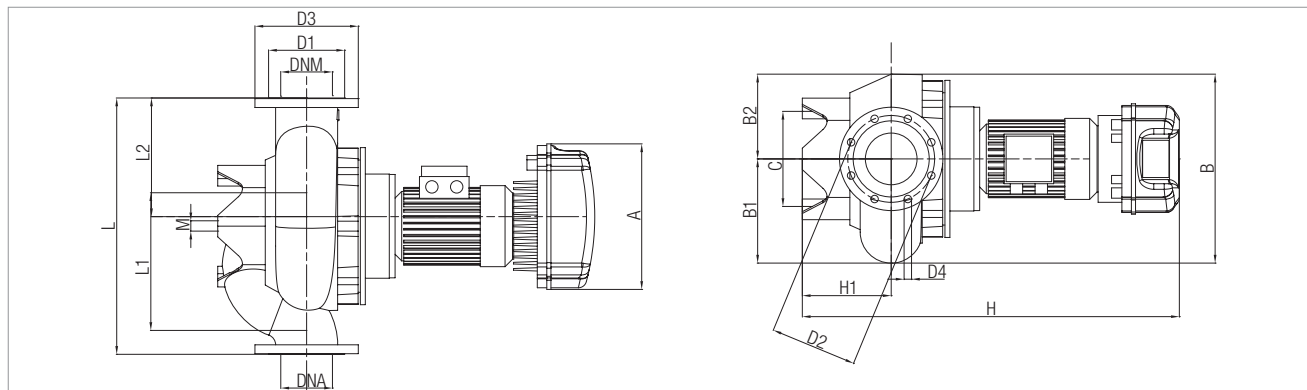

MODEL	ELECTRICAL DATA						
	POWER INPUT 50-60 Hz	POLES	n r.p.m.	P1 MAX kW	P2 NOMINAL		In A
					kW	HP	
CM-GE 125-1560/A/BAQE/7,5 T MCE 110/C*	3 x 400 V ~	4	1469	9,93	7,5	10	14,4
CM-GE 125-2100/A/BAQE/11 T MCE 110/C	3 x 400 V ~	4	1475	14,3	11	15	22,4

* ΔP-v proportional differential pressure adjustment mode also available.

MODEL	A	B	B1	B2	B MAX	C	D	D1	D2	D3	D4	H	H1	H2	L	L1	L2	M	N	Y	DNA	DNM	PACKING DIMENSIONS			VOL. (m ³)	WEIGHT Kg
																							L/A	L/B	H		
CM-GE 125-1560/A/BAQE/7,5 T MCE 110/C	426	457	252	205	-	230	-	188	210	250	8x18	1199	215	-	620	310	310	16	-	-	125	125	700	600	1220	0,51	228
CM-GE 125-2100/A/BAQE/11 T MCE 110/C	426	519	274	245	-	230	-	188	210	250	8x18	1267	215	-	800	400	400	16	-	-	125	125	900	550	1200	0,59	307

CM-GE 125 4 POLES - ELECTRONIC IN-LINE PUMPS FOR CIRCULATION SYSTEMS

Pumped liquid temperature range: from -10 °C to +140°C - Maximum ambient temperature: +40°C

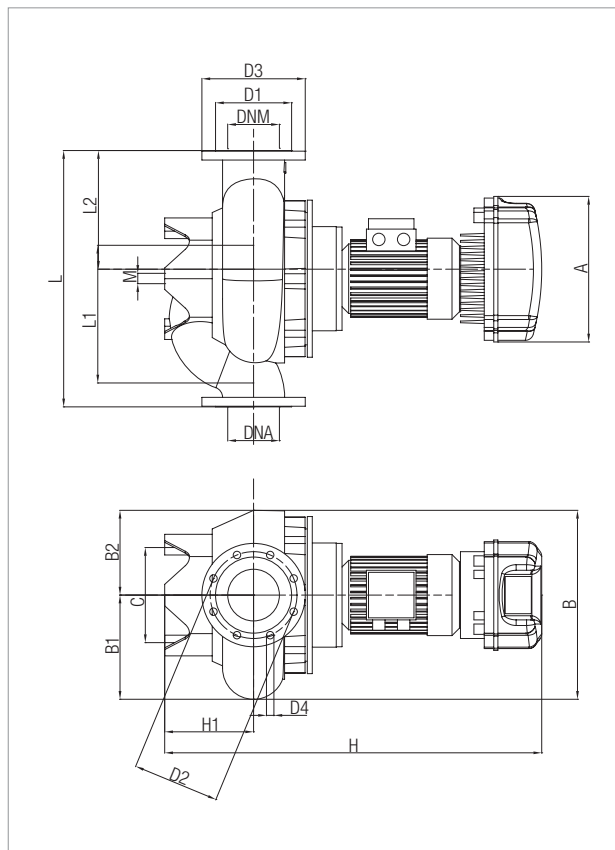
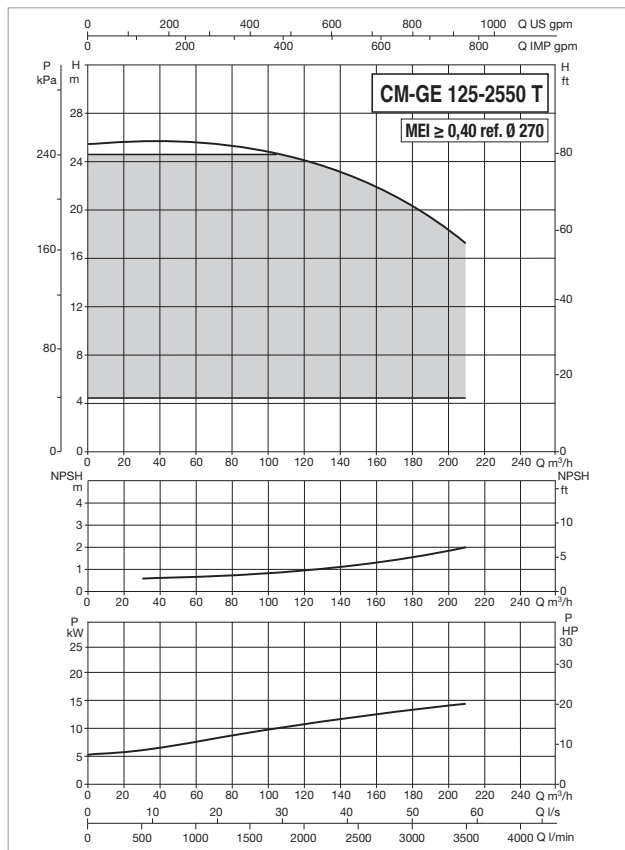

The MEI values for inverter controlled pumps refer to similar versions without electronics.

The performance curves are based on kinematic viscosity values = 1 mm²/s and density equal to 1000 kg/m³. Curve tolerance according to ISO 9906.

MODEL	ELECTRICAL DATA						
	POWER INPUT 50-60 Hz	POLES	n r.p.m.	P1 MAX kW	P2 NOMINAL		In A
					kW	HP	
CM-GE 125-2550/A/BAQE/15 T MCE 150/C*	3 x 400 V ~	4	1470	17,07	15	20	30,5

* ΔP-v proportional differential pressure adjustment mode also available.

MODEL	A	B	B1	B2	B MAX	C	D	D1	D2	D3	D4	H	H1	H2	L	L1	L2	M	N	Y	DNA	DNM	PACKING DIMENSIONS			VOL. (m ³)	WEIGHT Kg
	L/A	L/B	H																								
CM-GE 125-2550/A/BAQE/15 T MCE 150/C	426	519	274	245	-	230	-	188	210	250	8x18	1407	215	-	800	400	400	16	-	-	125	125	900	550	1200	0,59	363

CM-GE 150 4 POLES - ELECTRONIC IN-LINE PUMPS FOR CIRCULATION SYSTEMS

Pumped liquid temperature range: from -10 °C to +140°C - Maximum ambient temperature: +40°C

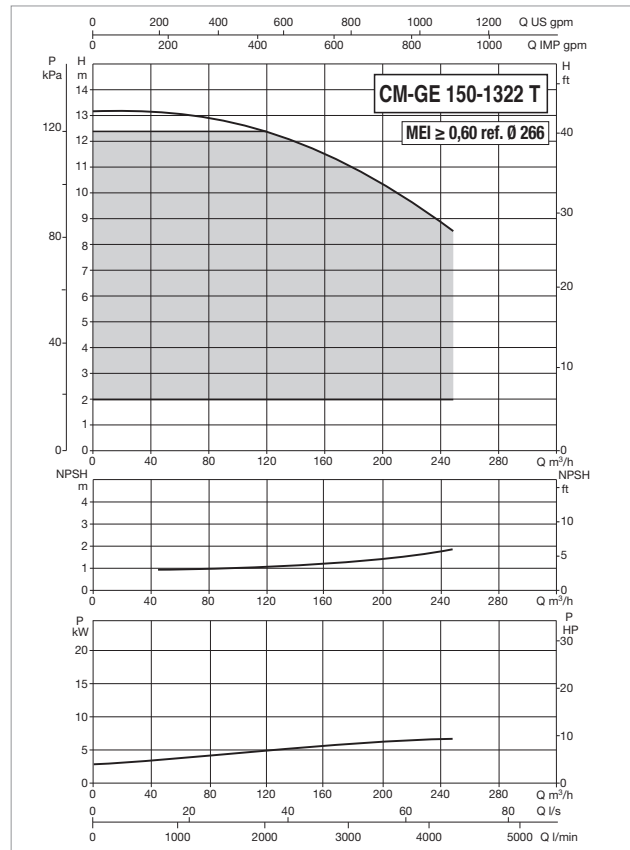
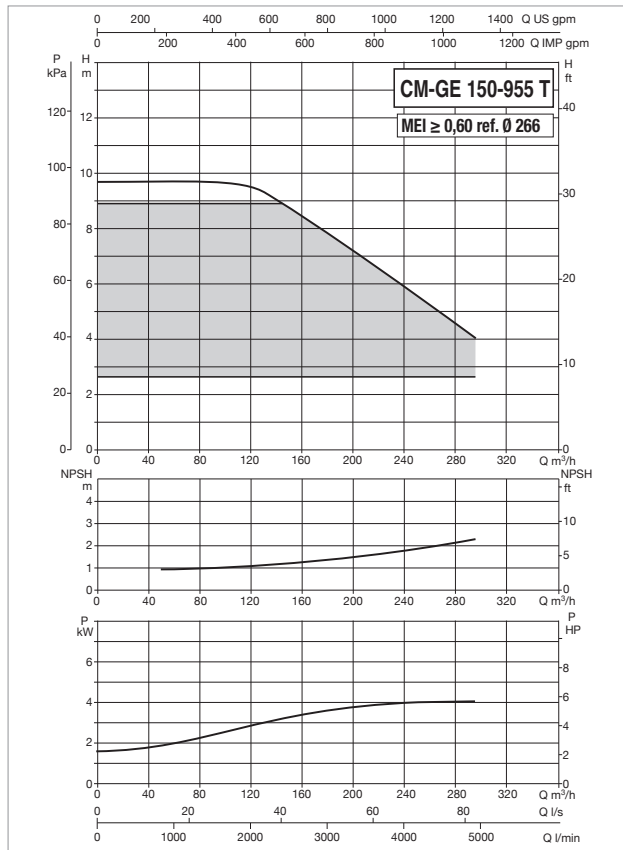

The MEI values for inverter controlled pumps refer to similar versions without electronics.

The performance curves are based on kinematic viscosity values = 1 mm²/s and density equal to 1000 kg/m³. Curve tolerance according to ISO 9906.

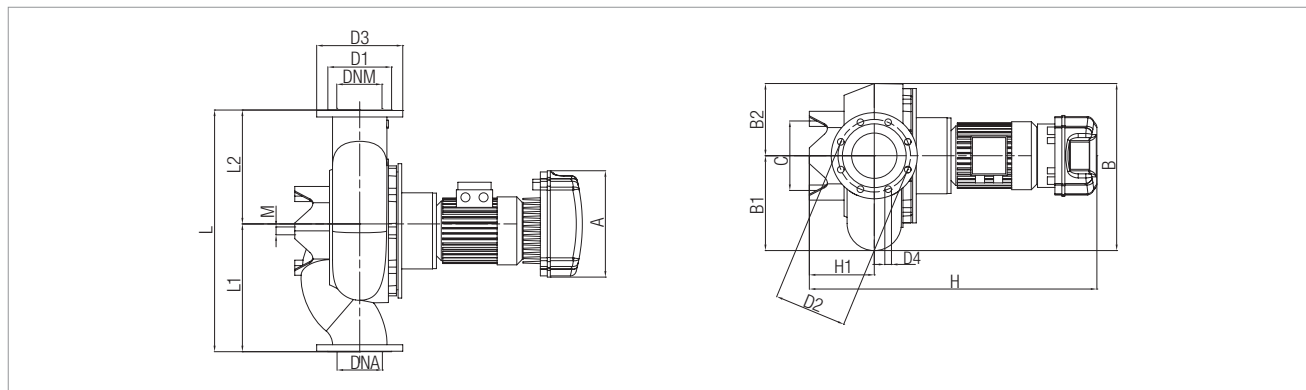

MODEL	ELECTRICAL DATA						
	POWER INPUT 50-60 Hz	POLES	n r.p.m.	P1 MAX kW	P2 NOMINAL		In A
					kW	HP	
CM-GE 150-955/A/BAQE/5,5 T MCE 55/C	3 x 400 V ~	4	1462	7,9	5,5	7,5	10,6
CM-GE 150-1322/A/BAQE/7,5 T MCE 110/C	3 x 400 V ~	4	1464	9,37	7,5	10	14,4

MODEL	A	B	B1	B2	B MAX	C	D	D1	D2	D3	D4	H	H1	H2	L	L1	L2	M	N	Y	DNA	DNM	PACKING DIMENSIONS			VOL. (m ³)	WEIGHT Kg
																							L/A	L/B	H		
CM-GE 150-955/A/BAQE/5,5 T MCE 55/C	353	538	299	239	-	230	-	212	240	285	8x22	1110	215	-	800	400	400	16	-	-	150	150	900	550	1200	0,59	274
CM-GE 150-1322/A/BAQE/7,5 T MCE 110/C	426	538	299	239	-	230	-	212	240	285	8x22	1208	215	-	800	400	400	16	-	-	150	150	900	550	1200	0,59	294

CM-GE 150 4 POLES - ELECTRONIC IN-LINE PUMPS FOR CIRCULATION SYSTEMS

Pumped liquid temperature range: from -10 °C to +140°C - Maximum ambient temperature: +40°C

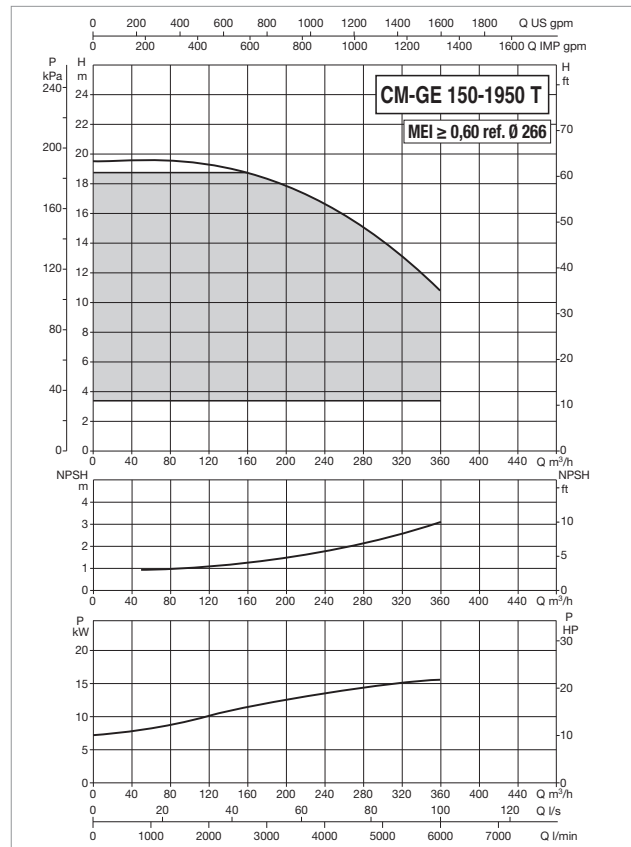
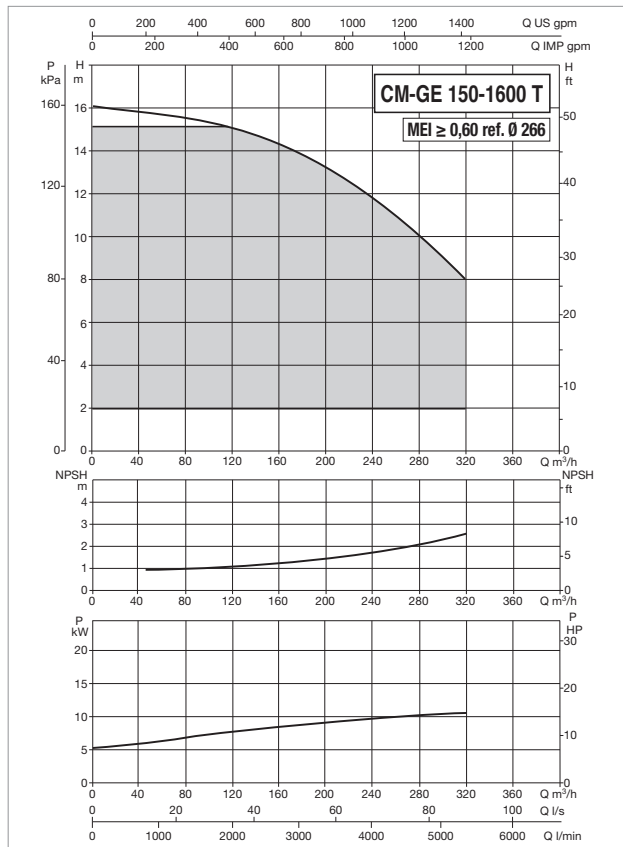

The MEI values for inverter controlled pumps refer to similar versions without electronics.

The performance curves are based on kinematic viscosity values = 1 mm²/s and density equal to 1000 kg/m³. Curve tolerance according to ISO 9906.

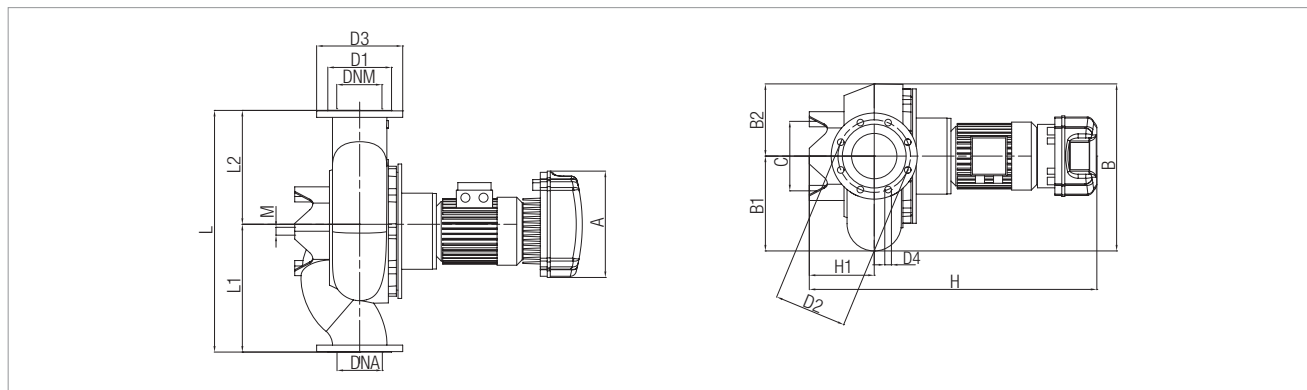

MODEL	ELECTRICAL DATA						
	POWER INPUT 50-60 Hz	POLES	n r.p.m.	P1 MAX kW	P2 NOMINAL		In A
					kW	HP	
CM-GE 150-1600/A/BAQE/11 T MCE 110/C*	3 x 400 V ~	4	1473	13,61	11	15	22,4
CM-GE 150-1950/A/BAQE/15 T MCE 150/C*	3 x 400 V ~	4	1472	18,39	15	20	30,5

* ΔP-v proportional differential pressure adjustment mode also available.

MODEL	A	B	B1	B2	B MAX	C	D	D1	D2	D3	D4	H	H1	H2	L	L1	L2	M	N	Y	DNA	DNM	PACKING DIMENSIONS			VOL. (m ³)	WEIGHT Kg
	L/A	L/B	H	L/A	L/B	H																					
CM-GE 150-1600/A/BAQE/11 T MCE 110/C	426	538	299	239	-	230	-	212	240	285	8x22	1270	215	-	800	400	400	16	-	-	150	150	900	550	1200	0,59	306
CM-GE 150-1950/A/BAQE/15 T MCE 150/C	426	538	299	239	-	230	-	212	240	285	8x22	1411	215	-	800	400	400	16	-	-	150	150	900	550	1500	0,74	356

DCM-GE 65 4 POLES - ELECTRONIC IN-LINE PUMPS FOR CIRCULATION SYSTEMS

Pumped liquid temperature range: from -10 °C to +140°C - Maximum ambient temperature: +40°C

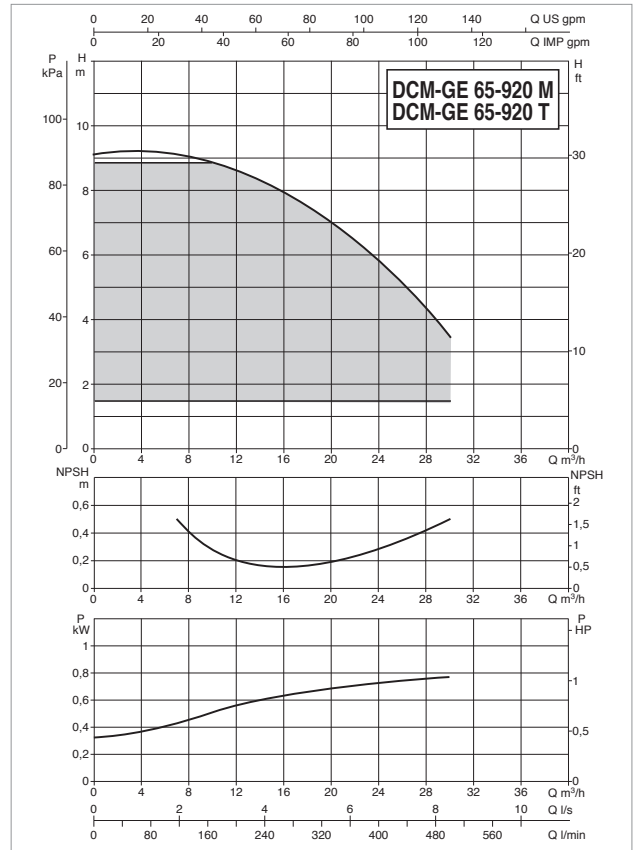
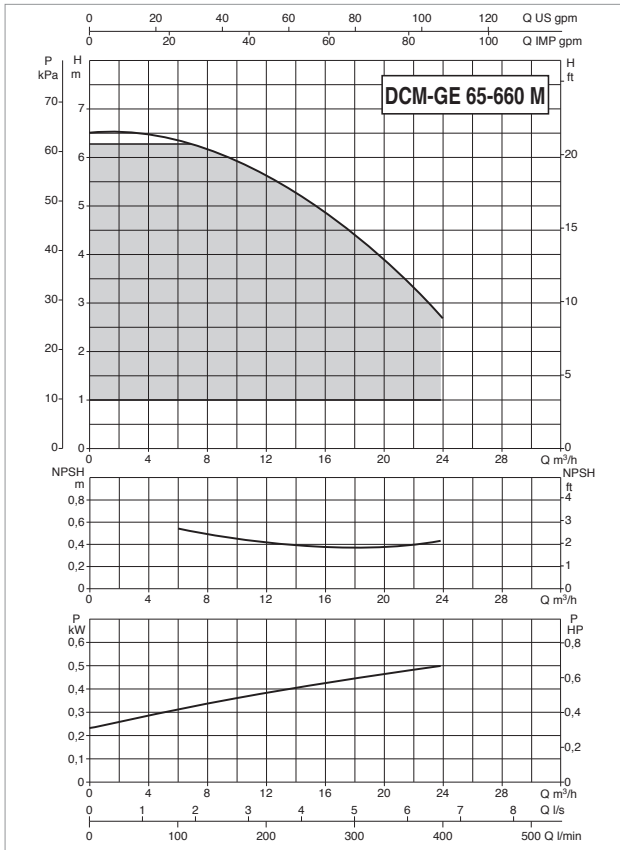

For the MEI index refer to the hydraulic data of the individual pump.

The performance curves are based on kinematic viscosity values = 1 mm²/s and density equal to 1000 kg/m³. Curve tolerance according to ISO 9906.

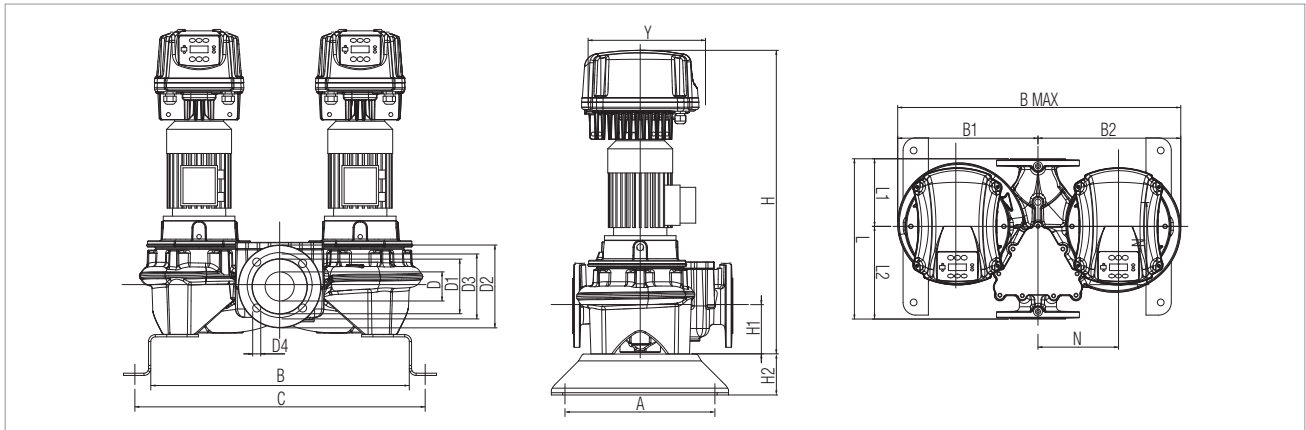

MODEL	ELECTRICAL DATA						
	POWER INPUT 50-60 Hz	POLES	n r.p.m.	P1 MAX kW	P2 NOMINAL		In A
					kW	HP	
DCM-GE 65-660/A/BAQE/0,55 M MCE 11/C*	1 x 230 V ~	4	1400	0,84	0,55	0,75	7,3
DCM-GE 65-920/A/BAQE/0,75 M MCE 11/C*	1 x 230 V ~	4	1430	1,23	0,75	1	9,8
DCM-GE 65-920/A/BAQE/0,75 T MCE 30/C*	3 x 400 V ~	4	1430	1,23	0,75	1	1,8

* ΔP-v proportional differential pressure adjustment mode also available.

MODEL	A	B	B1	B2	B MAX	C	D	D1	D2	D3	D4	H	H1	H2	L	L1	L2	M	N	Y	DNA	DNM	PACKING DIMENSIONS			VOL. (m ³)	WEIGHT Kg
																							L/A	L/B	H		
DCM-GE 65-660/A/BAQE/0,55 M MCE 11/C	330	569	315	320	635	639	-	122	185	145	4	733	107	100	358	151	207	M16	180	262	65	65	358	635	733	0,17	141
DCM-GE 65-920/A/BAQE/0,75 M MCE 11/C	330	569	315	320	635	639	-	122	185	145	HOLES Ø18	733	107	100	358	151	207	M16	180	262	65	65	358	635	733	0,17	144
DCM-GE 65-920/A/BAQE/0,75 T MCE 30/C	330	569	315	320	635	639	-	122	185	145	HOLES Ø18	730	107	100	358	151	207	M16	180	262	65	65	358	635	730	0,17	146

DCM-GE 65 4 POLES - ELECTRONIC IN-LINE PUMPS FOR CIRCULATION SYSTEMS

Pumped liquid temperature range: from -10 °C to +140°C - Maximum ambient temperature: +40°C

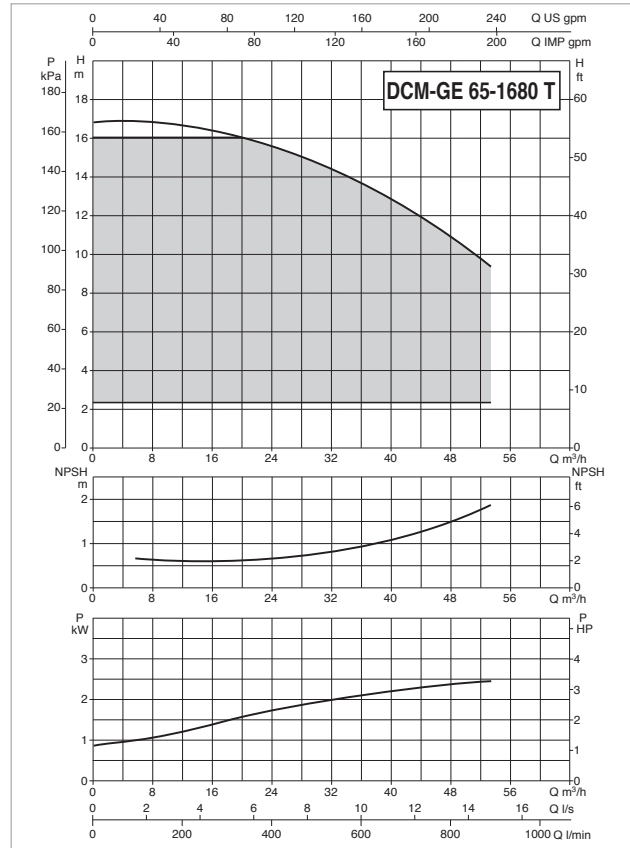
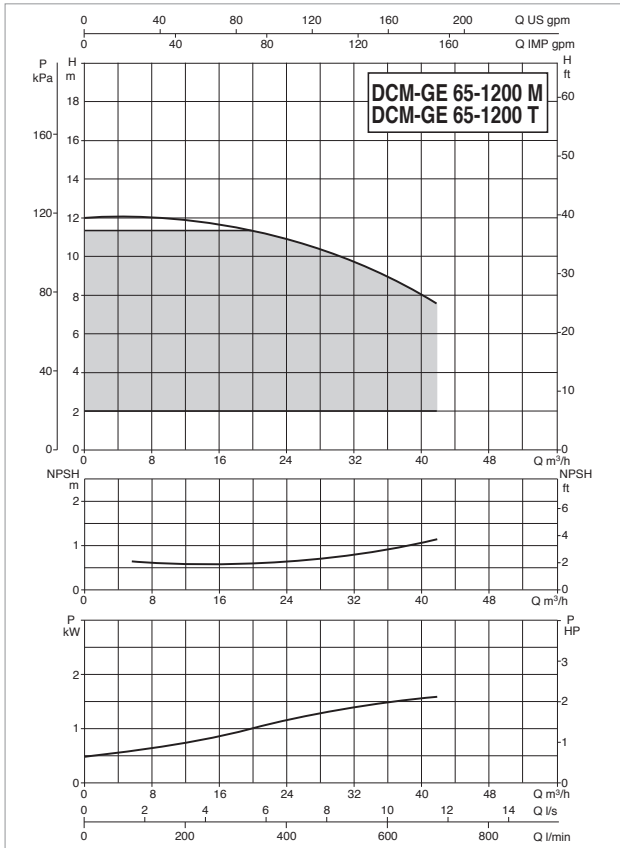

For the MEI index refer to the hydraulic data of the individual pump.

The performance curves are based on kinematic viscosity values = 1 mm²/s and density equal to 1000 kg/m³. Curve tolerance according to ISO 9906.

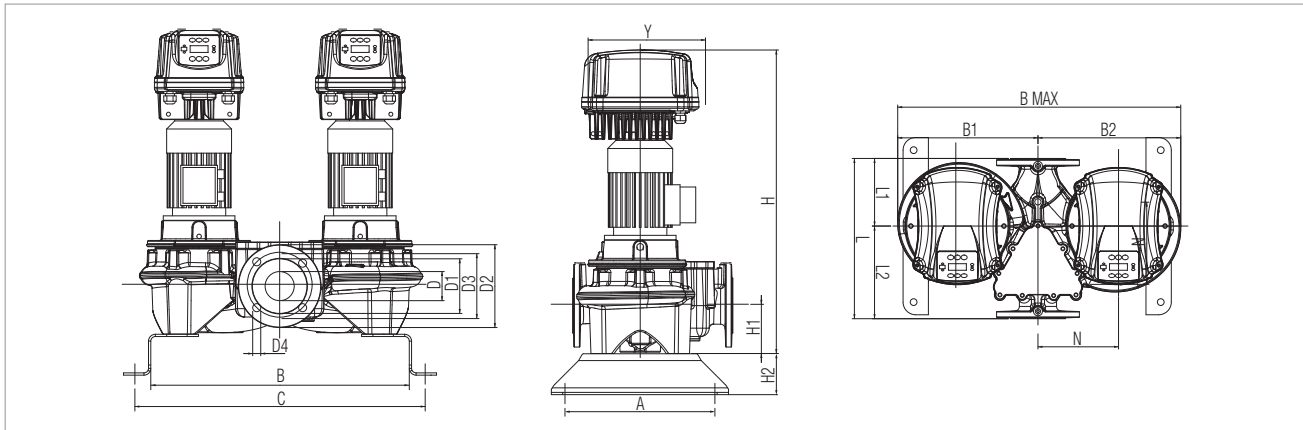

MODEL	ELECTRICAL DATA						
	POWER INPUT 50-60 Hz	POLES	n r.p.m.	P1 MAX kW	P2 NOMINAL		In A
					kW	HP	
DCM-GE 65-1200/A/BAQE/1,5 M MCE 11/C*	1 x 230 V ~	4	1430	2,1	1,5	2	15,4
DCM-GE 65-1200/A/BAQE/1,5 T MCE 30/C*	3 x 400 V ~	4	1430	2,1	1,5	2	3,6
DCM-GE 65-1680/A/BAQE/3 T MCE 30/C*	3 x 400 V ~	4	1448	2,83	3	4	6,8

* ΔP-v proportional differential pressure adjustment mode also available.

MODEL	A	B	B1	B2	B MAX	C	D	D1	D2	D3	D4	H	H1	H2	L	L1	L2	M	N	Y	DNA	DNM	PACKING DIMENSIONS			VOL. (m ³)	WEIGHT Kg
																							L/A	L/B	H		
DCM-GE 65-1200/A/BAQE/1,5 M MCE 11/C	330	649	387	395	782	719	-	122	185	145	4	821	125	100	475	177	298	M16	220	262	65	65	475	782	821	0,3	193
DCM-GE 65-1200/A/BAQE/1,5 T MCE 30/C	330	649	387	395	782	719	-	122	185	145	4	824	125	100	475	177	298	M16	220	262	65	65	475	782	824	0,31	195
DCM-GE 65-1680/A/BAQE/3 T MCE 30/C	330	649	387	395	782	719	-	122	185	145	4	840	125	100	475	177	298	M16	220	352	65	65	475	782	840	0,31	206



DCM-GE 65 4 POLES - ELECTRONIC IN-LINE PUMPS FOR CIRCULATION SYSTEMS

Pumped liquid temperature range: from -10 °C to +140°C - Maximum ambient temperature: +40°C

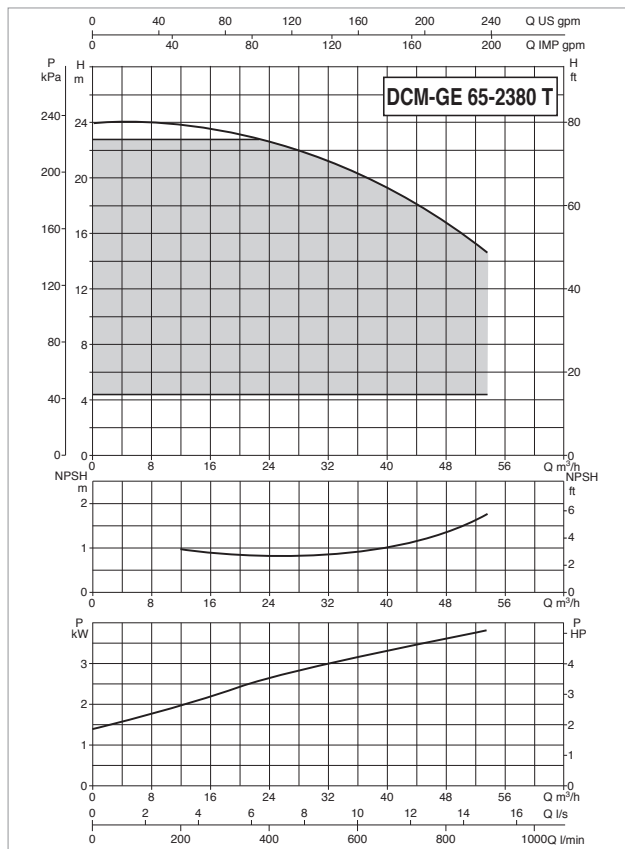

For the MEI index refer to the hydraulic data of the individual pump.

The performance curves are based on kinematic viscosity values = 1 mm²/s and density equal to 1000 kg/m³. Curve tolerance according to ISO 9906.

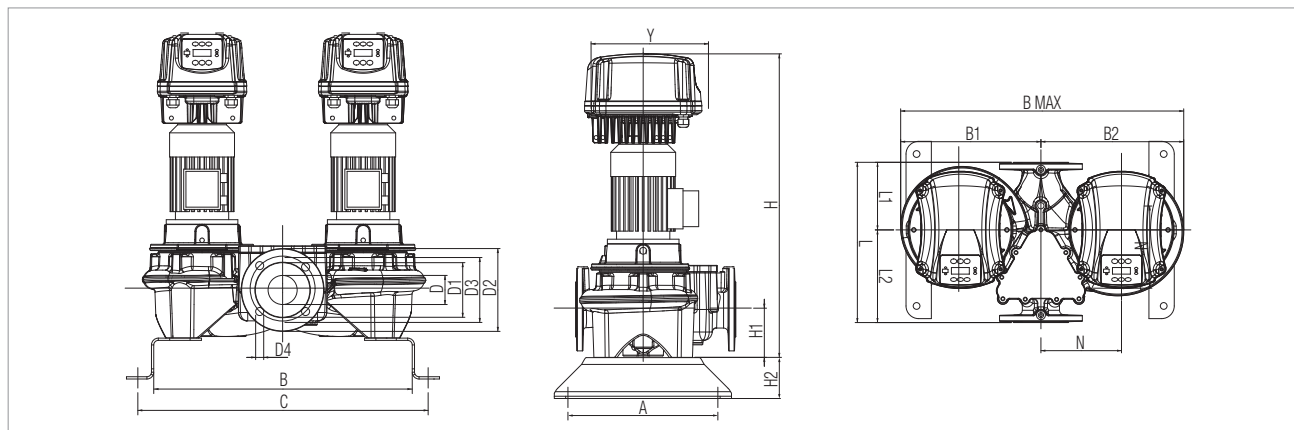

MODEL	ELECTRICAL DATA						
	POWER INPUT 50-60 Hz	POLES	n r.p.m.	P1 MAX kW	P2 NOMINAL		In A
					kW	HP	
DCM-GE 65-2380/A/BAQE/4 T MCE 30/C *	3 x 400 V ~	4	1449	4,47	4	5,5	8,2

* ΔP-v proportional differential pressure adjustment mode also available.

MODEL	A	B	B1	B2	B MAX	C	D	D1	D2	D3	D4	H	H1	H2	L	L1	L2	M	N	Y	DNA	DNM	PACKING DIMENSIONS			VOL. (m ³)	WEIGHT Kg
	L/A	L/B	L/B	H							4 HOLES Ø 18																
DCM-GE 65-2380/A/BAQE/4 T MCE 30/C	330	649	387	395	782	719	-	122	185	145	4 HOLES Ø 18	925	125	100	475	177	298	M16	220	352	65	65	475	782	925	0,34	233

DCM-GE 80 4 POLES - ELECTRONIC IN-LINE PUMPS FOR CIRCULATION SYSTEMS

Pumped liquid temperature range: from -10 °C to +140°C - Maximum ambient temperature: +40°C

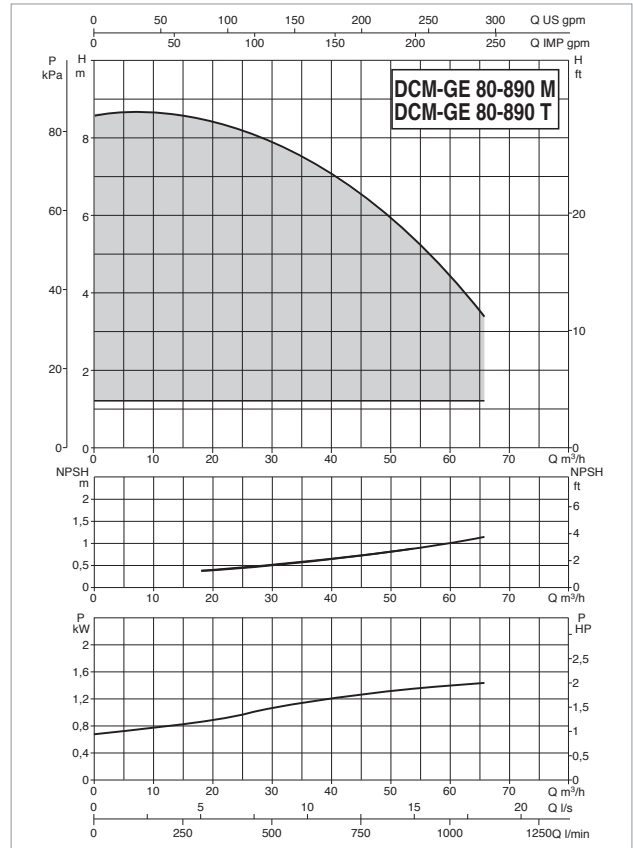
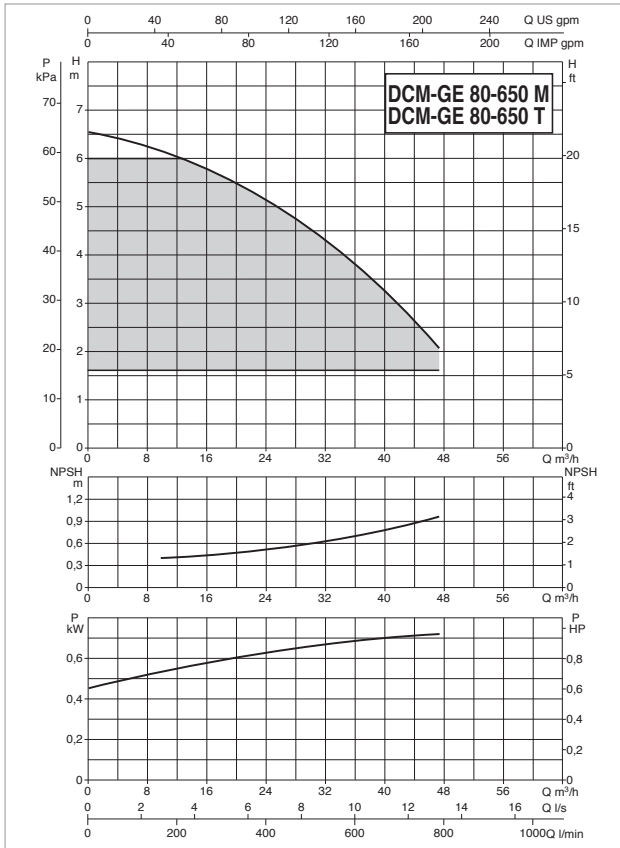

For the MEI index refer to the hydraulic data of the individual pump.

The performance curves are based on kinematic viscosity values = 1 mm²/s and density equal to 1000 kg/m³. Curve tolerance according to ISO 9906.

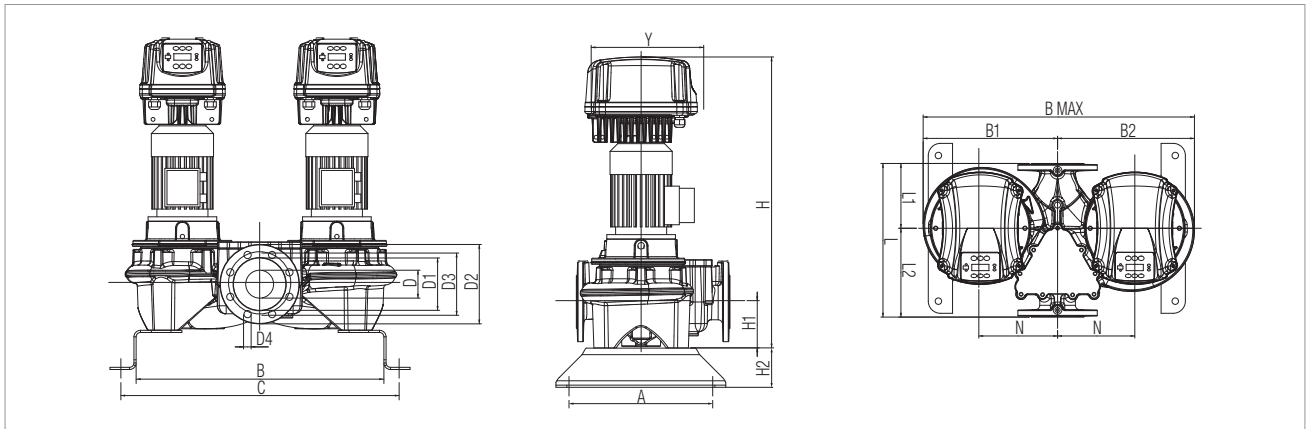

MODEL	ELECTRICAL DATA						
	POWER INPUT 50-60 Hz	POLES	n r.p.m.	P1 MAX kW	P2 NOMINAL		In A
					kW	HP	
DCM-GE 80-650/A/BAQE/0,75 M MCE 11/C*	1 x 230 V ~	4	1430	1,24	0,75	1	9,8
DCM-GE 80-650/A/BAQE/0,75 T MCE 30/C*	3 x 400 V ~	4	1430	1,24	0,75	1	1,8
DCM-GE 80-890/A/BAQE/1,5 T MCE 30/C*	3 x 400 V ~	4	1430	2,07	1,5	2	3,6
DCM-GE 80-890/A/BAQE/1,5 M MCE 11/C*	1 x 230 V ~	4	1430	1,87	1,5	2	13,9

* ΔP-v proportional differential pressure adjustment mode also available.

MODEL	A	B	B1	B2	B MAX	C	D	D1	D2	D3	D4	H	H1	H2	L	L1	L2	M	N	Y	DN	DNM	PACKING DIMENSIONS			VOL. (m ³)	WEIGHT Kg
																							L/A	L/B	H		
DCM-GE 80-650/A/BAQE/0,75 M MCE 11/C	330	580	305	310	615	650	-	137	200	160	8 HOLES Ø 18	745	115	100	360	165	195	M16	180	262	80	80	360	615	745	0,16	134
DCM-GE 80-650/A/BAQE/0,75 T MCE 30/C	330	580	305	310	615	650	-	137	200	160	8 HOLES Ø 18	742	115	100	360	165	195	M16	180	262	80	80	360	615	742	0,16	136
DCM-GE 80-890/A/BAQE/1,5 T MCE 30/C	620	620	355	365	720	690	-	137	200	160	8 HOLES Ø 18	822	115	100	440	180	260	M16	200	262	80	80	440	720	822	0,26	213
DCM-GE 80-890/A/BAQE/1,5 M MCE 11/C	620	620	355	365	720	690	-	137	200	160	8 HOLES Ø 18	825	115	100	440	180	260	M16	200	262	80	80	440	720	825	0,26	211

DCM-GE 80 4 POLES - ELECTRONIC IN-LINE PUMPS FOR CIRCULATION SYSTEMS

Pumped liquid temperature range: from -10 °C to +140°C - Maximum ambient temperature: +40°C

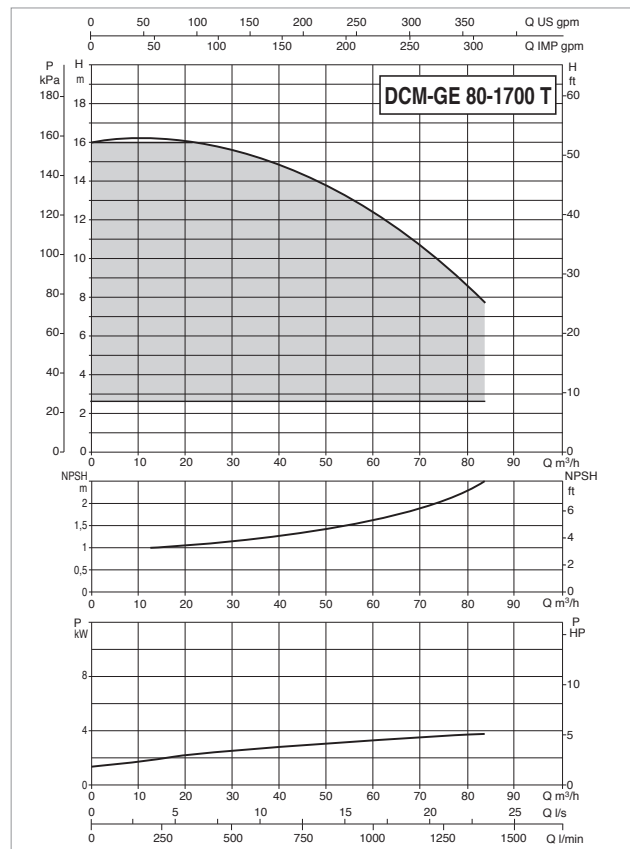
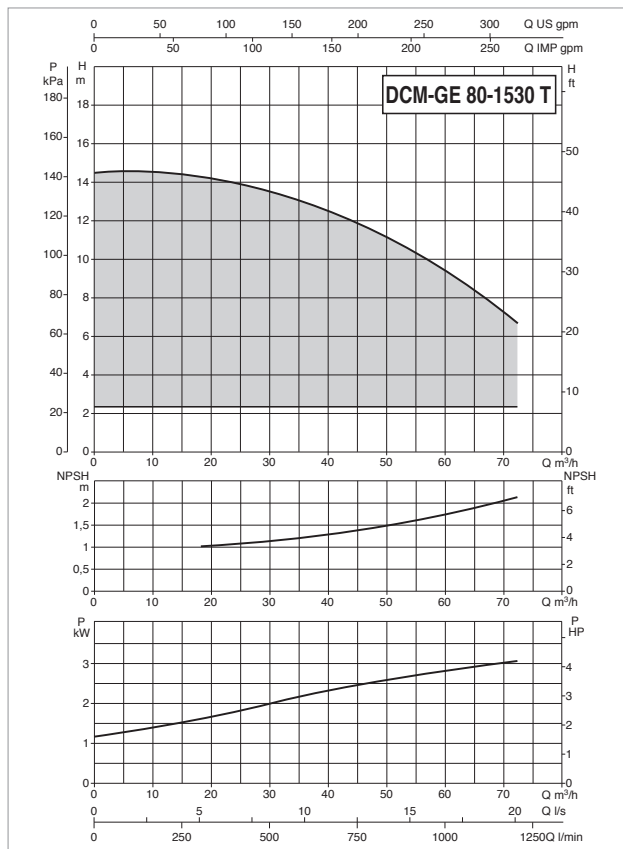

For the MEI index refer to the hydraulic data of the individual pump.

The performance curves are based on kinematic viscosity values = 1 mm²/s and density equal to 1000 kg/m³. Curve tolerance according to ISO 9906.

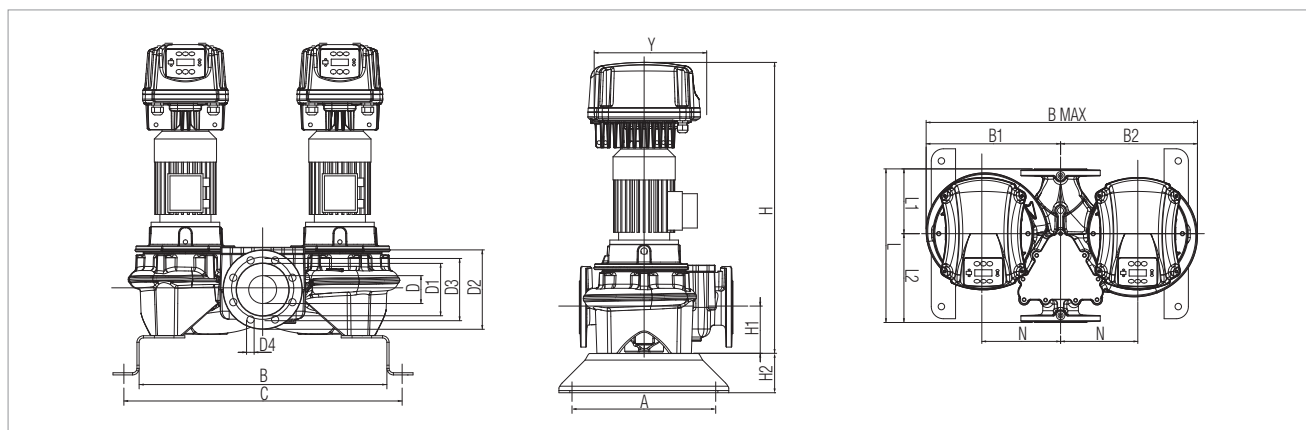

MODEL	ELECTRICAL DATA						
	POWER INPUT 50-60 Hz	POLES	n r.p.m.	P1 MAX kW	P2 NOMINAL		In A
					kW	HP	
DCM-GE 80-1530/A/BAQE/3 T MCE 30/C*	3 x 400 V ~	4	1441	3,74	3	4	6,8
DCM-GE 80-1700/A/BAQE/4 T MCE 55/C*	3 x 400 V ~	4	1452	4,77	4	5,5	10,3

* ΔP-v proportional differential pressure adjustment mode also available.

MODEL	A	B	B1	B2	B MAX	C	D	D1	D2	D3	D4	H	H1	H2	L	L1	L2	M	N	Y	DNA	DNM	PACKING DIMENSIONS			VOL. (m ³)	WEIGHT Kg
																							L/A	L/B	H		
DCM-GE 80-1530/A/BAQE/3 T MCE 30/C	362	662	405	415	820	690	-	137	200	160	8 HOLES Ø 18	846	115	100	500	220	280	M16	235	352	80	80	500	820	846	0,35	251
DCM-GE 80-1700/A/BAQE/4 T MCE 55/C	362	662	405	415	820	732	-	137	200	160	Ø 18	931	115	100	500	220	280	M16	235	352	80	80	500	820	931	0,38	277

DCM-GE 80 4 POLES - ELECTRONIC IN-LINE PUMPS FOR CIRCULATION SYSTEMS

Pumped liquid temperature range: from -10 °C to +140°C - Maximum ambient temperature: +40°C

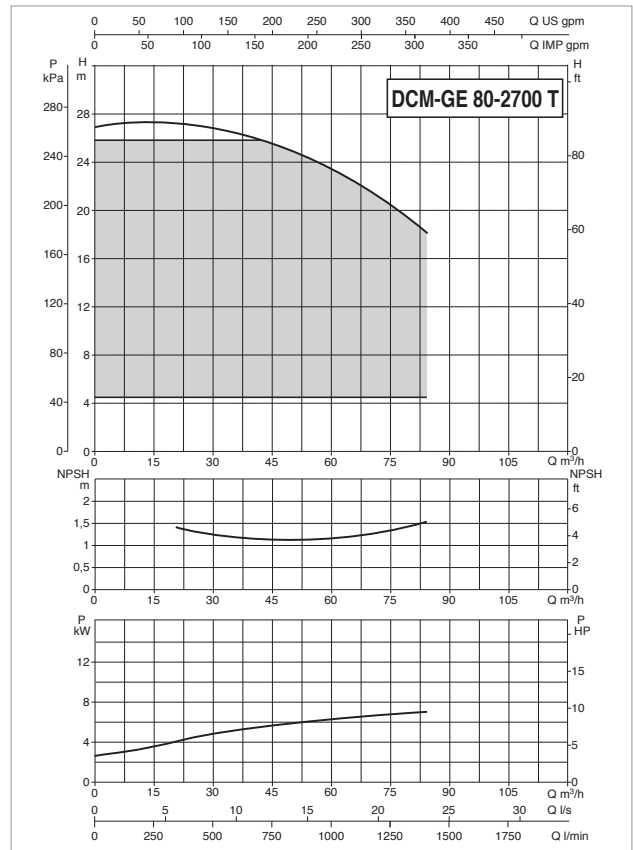
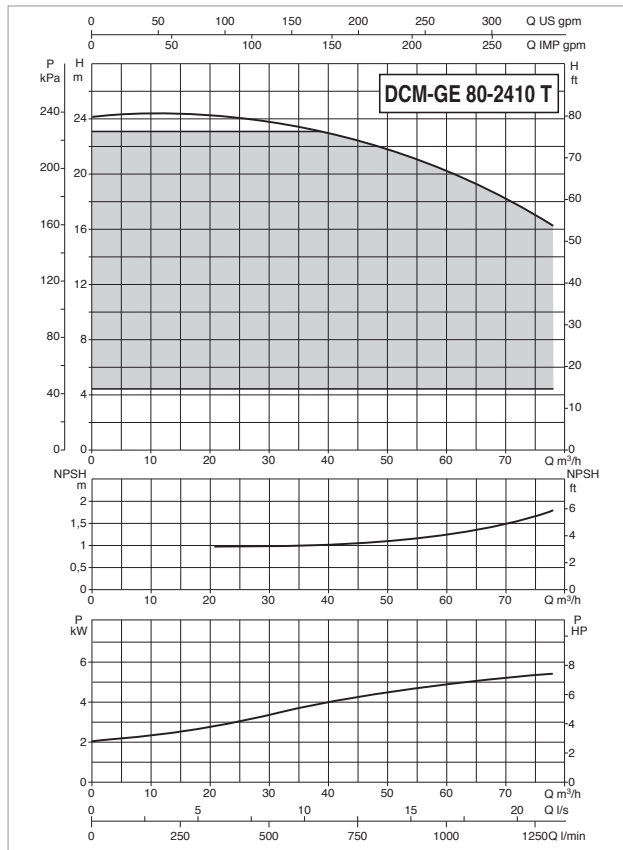

For the MEI index refer to the hydraulic data of the individual pump.

The performance curves are based on kinematic viscosity values = 1 mm²/s and density equal to 1000 kg/m³. Curve tolerance according to ISO 9906.

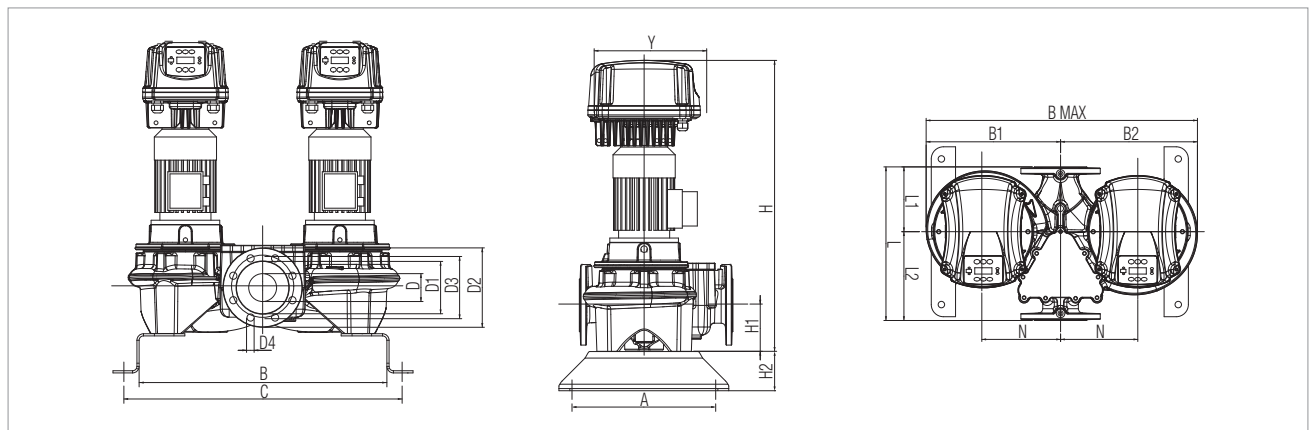

MODEL	ELECTRICAL DATA						
	POWER INPUT 50-60 Hz	POLES	n r.p.m.	P1 MAX kW	P2 NOMINAL		In A
					kW	HP	
DCM-GE 80-2410/A/BAQE/5,5 T MCE 55/C*	3 x 400 V ~	4	1461	6,8	5,5	7,5	10,6
DCM-GE 80-2700/A/BAQE/7,5 T MCE 110/C*	3 x 400 V ~	4	1463	9,15	7,5	10	14,4

* ΔP-v proportional differential pressure adjustment mode also available.

MODEL	A	B	B1	B2	B MAX	C	D	D1	D2	D3	D4	H	H1	H2	L	L1	L2	M	N	Y	DNA	DNM	PACKING DIMENSIONS L/A L/B H			VOL. (m ³)	WEIGHT Kg
DCM-GE 80-2410/A/BAQE/5,5 T MCE 55/C	500	804	530	540	1070	924	-	137	200	160	8 HOLES	999	140	100	620	280	340	M16	300	352	80	80	620	1070	999	0,66	442
DCM-GE 80-2700/A/BAQE/7,5 T MCE 110/C	500	804	530	540	1070	924	-	137	200	160	0 18	1087	140	100	620	280	340	M16	300	425	80	80	620	1070	1087	0,72	499

DCM-GE 80 4 POLES - ELECTRONIC IN-LINE PUMPS FOR CIRCULATION SYSTEMS

Pumped liquid temperature range: from -10 °C to +140°C - Maximum ambient temperature: +40°C

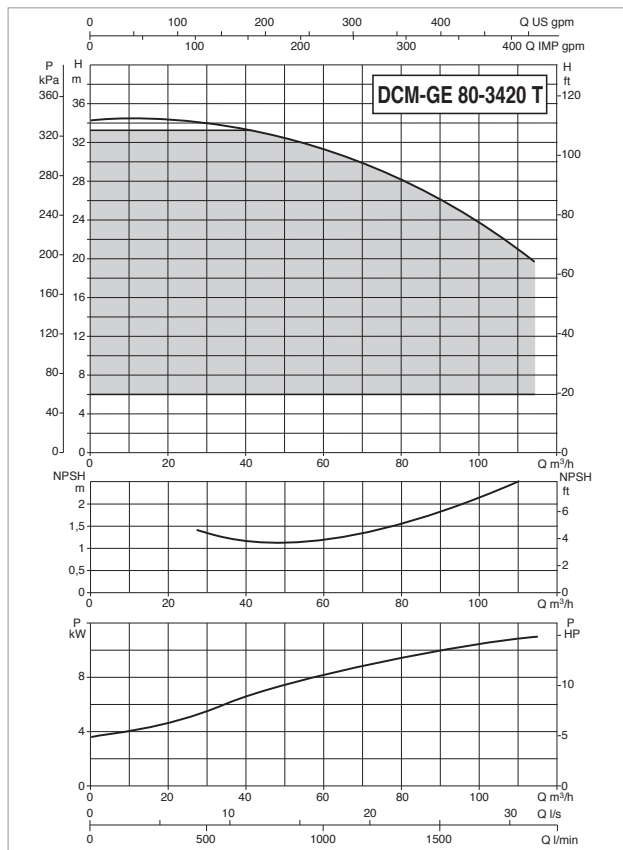

For the MEI index refer to the hydraulic data of the individual pump.

The performance curves are based on kinematic viscosity values = 1 mm²/s and density equal to 1000 kg/m³. Curve tolerance according to ISO 9906.

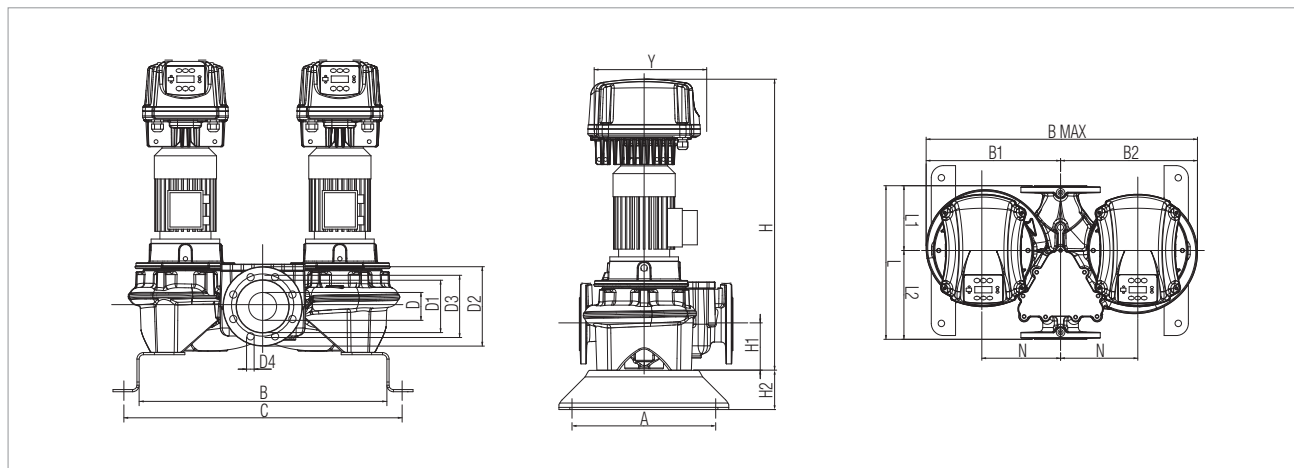

MODEL	ELECTRICAL DATA						
	POWER INPUT 50-60 Hz	POLES	n r.p.m.	P1 MAX kW	P2 NOMINAL		In A
					kW	HP	
DCM-GE 80-3420/A/BAQE/11 T MCE 110/C*	3 x 400 V ~	4	1472	13,36	11	15	22,4

* ΔP-v proportional differential pressure adjustment mode also available.

MODEL	A	B	B1	B2	B MAX	C	D	D1	D2	D3	D4	H	H1	H2	L	L1	L2	M	N	Y	D NA	D NM	PACKING DIMENSIONS			VOL. (m ³)	WEIGHT Kg
	L/A	L/B	L/B	H	L/A	L/B	H																				
DCM-GE 80-3420/A/BAQE/11 T MCE 110/C	500	804	530	540	1070	924	-	137	200	160	8 HOLES Ø 18	1192	140	100	620	280	340	M16	300	425	80	80	620	1070	1192	0,79	533

DCM-GE 100 4 POLES - ELECTRONIC IN-LINE PUMPS FOR CIRCULATION SYSTEMS

Pumped liquid temperature range: from -10 °C to +140°C - Maximum ambient temperature: +40°C

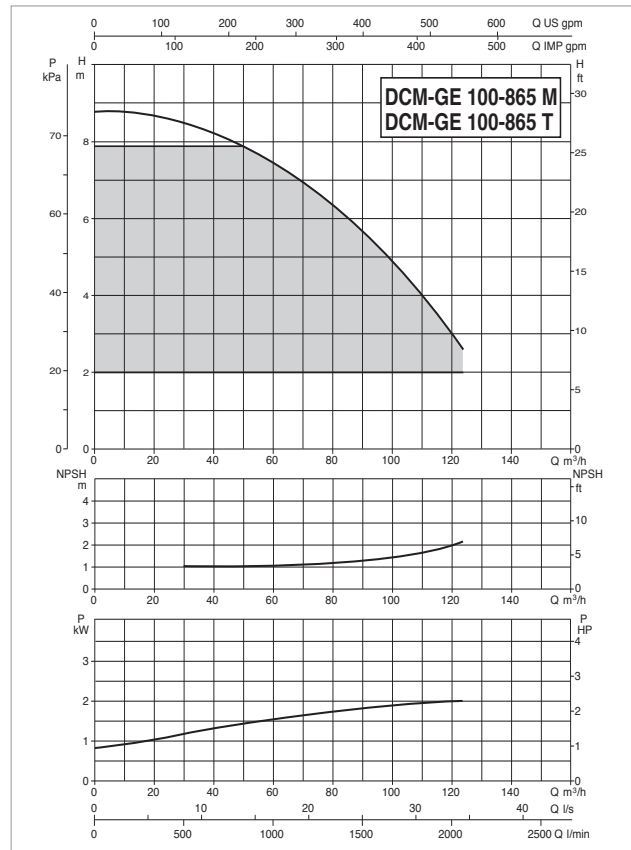
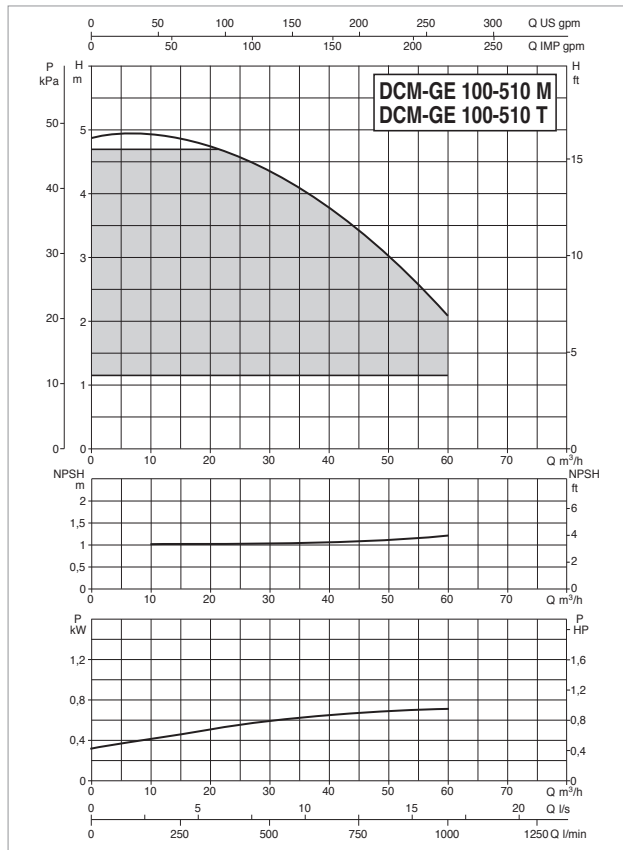

For the MEI index refer to the hydraulic data of the individual pump.

The performance curves are based on kinematic viscosity values = 1 mm²/s and density equal to 1000 kg/m³. Curve tolerance according to ISO 9906.

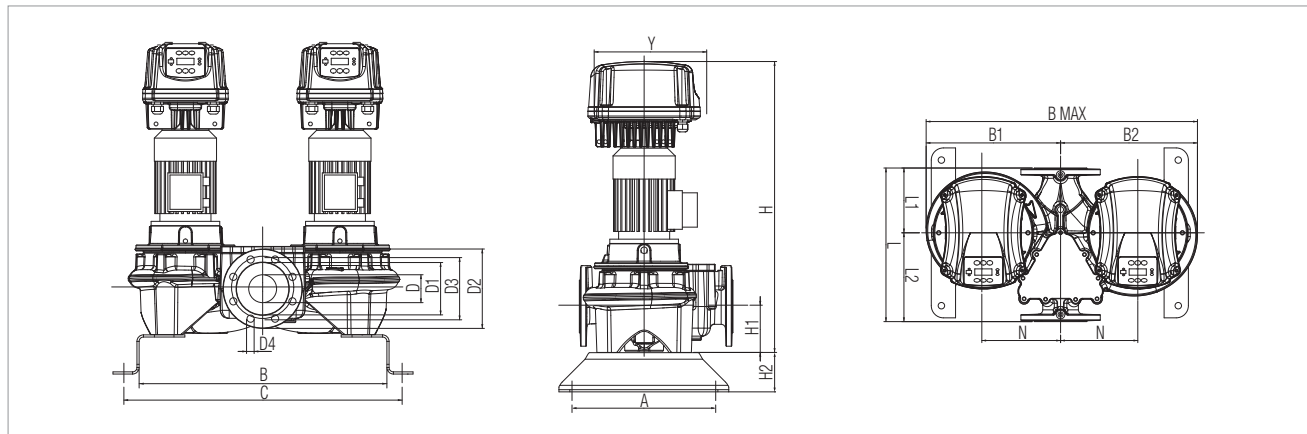

MODEL	ELECTRICAL DATA						
	POWER INPUT 50-60 Hz	POLES	n r.p.m.	P1 MAX kW	P2 NOMINAL		In A
					kW	HP	
DCM-GE 100-510/A/BAQE/0,75 M MCE 11/C*	1 x 230 V ~	4	1430	1,21	0,75	1	9,7
DCM-GE 100-510/A/BAQE/0,75 T MCE 30/C	3 x 400 V ~	4	1430	1,21	0,75	1	1,8
DCM-GE 100-865/A/BAQE/2,2 M MCE 22/C*	1 x 230 V ~	4	1430	2,94	2,2	3	20,7
DCM-GE 100-865/A/BAQE/2,2 T MCE 30/C*	3 x 400 V ~	4	1430	2,94	2,2	3	5,9

* ΔP-v proportional differential pressure adjustment mode also available.

MODEL	A	B	B1	B2	B MAX	C	D	D1	D2	D3	D4	H	H1	H2	L	L1	L2	M	N	Y	DNA	DNM	PACKING DIMENSIONS			VOL. (m ³)	WEIGHT Kg
																							L/A	L/B	H		
DCM-GE 100-510/A/BAQE/0,75 M MCE 11/C	362	637	330	345	675	717	-	156	220	180	772	140	100	500	191	309	M16	200	262	100	100	500	675	772	0,26	218	
DCM-GE 100-510/A/BAQE/0,75 T MCE 30/C	362	637	330	345	675	717	-	156	220	180	769	140	100	500	191	309	M16	200	262	100	100	500	675	769	0,26	220	
DCM-GE 100-865/A/BAQE/2,2 M MCE 22/C	362	733	395	410	805	813	-	156	220	180	847	140	100	550	221	329	M16	235	352	100	100	550	805	847	0,38	261	
DCM-GE 100-865/A/BAQE/2,2 T MCE 30/C	362	733	395	410	805	813	-	156	220	180	847	140	100	550	221	329	M16	235	352	100	100	550	805	847	0,38	263	

DCM-GE 100 4 POLES - ELECTRONIC IN-LINE PUMPS FOR CIRCULATION SYSTEMS

Pumped liquid temperature range: from -10 °C to +140°C - Maximum ambient temperature: +40°C

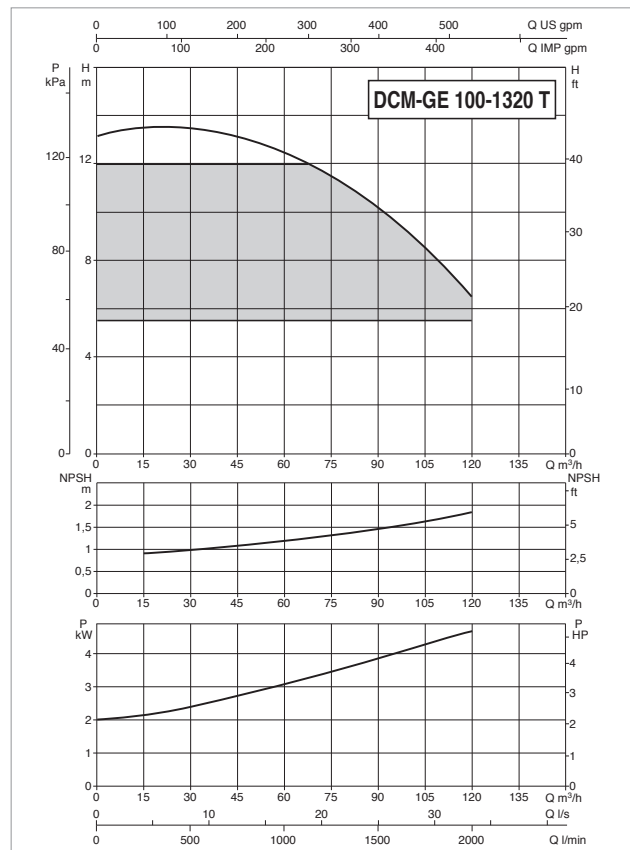
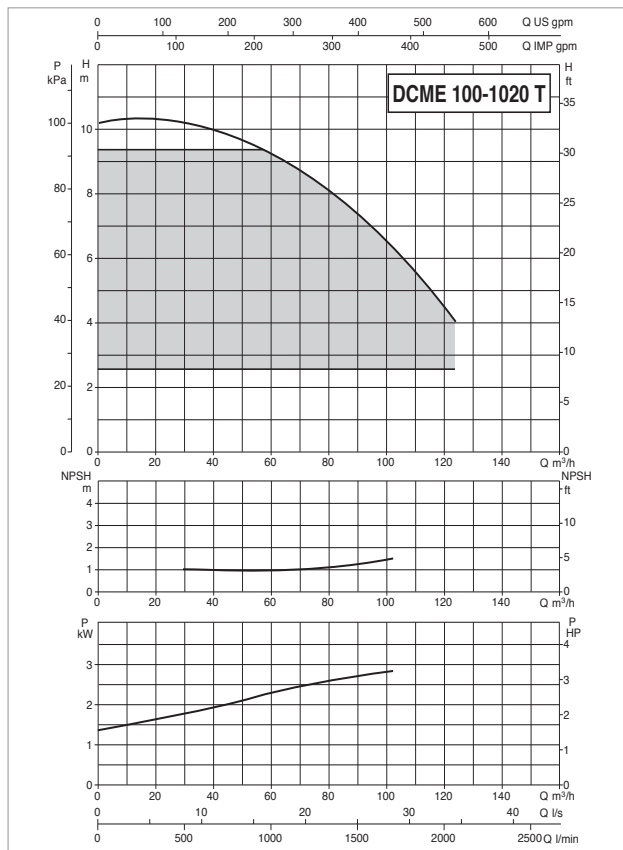

For the MEI index refer to the hydraulic data of the individual pump.

The performance curves are based on kinematic viscosity values = 1 mm²/s and density equal to 1000 kg/m³. Curve tolerance according to ISO 9906.

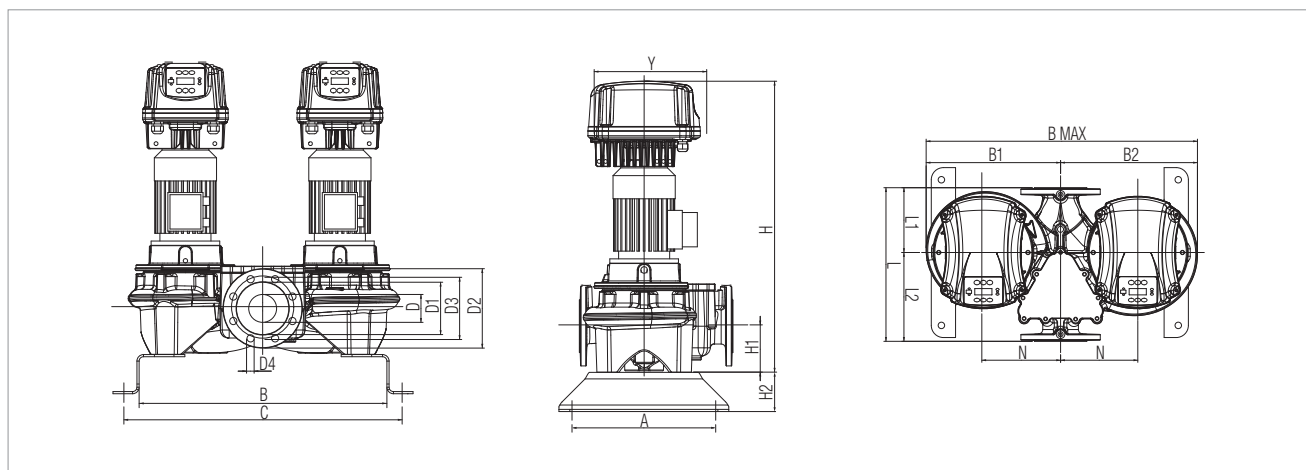

MODEL	ELECTRICAL DATA						
	POWER INPUT 50-60 Hz	POLES	n r.p.m.	P1 MAX kW	P2 NOMINAL		In A
					kW	HP	
DCM-GE 100-1020/A/BAQE/3 T MCE 30/C*	3 x 400 V ~	4	1441	3,77	3	4	6,8
DCM-GE 100-1320/A/BAQE/4 T MCE 55/C*	3 x 400 V ~	4	1450	4,81	4	5,5	8,2

* ΔP-v proportional differential pressure adjustment mode also available.

MODEL	A	B	B1	B2	B MAX	C	D	D1	D2	D3	D4	H	H1	H2	L	L1	L2	M	N	Y	DNA	DNM	PACKING DIMENSIONS			VOL. (m ³)	WEIGHT Kg
																							L/A	L/B	H		
DCM-GE 100-1020/A/BAQE/3 T MCE 30/C	362	733	395	410	805	813	-	156	220	180	8 HOLES Ø18	862	140	100	550	221	329	M16	235	352	100	100	550	805	862	0,38	264
DCM-GE 100-1320/A/BAQE/4 T MCE 55/C	362	753	430	440	870	833	-	156	220	180	Ø18	1007	140	100	550	221	329	M16	250	352	100	100	550	870	1007	0,48	308

DCM-GE 100 4 POLES - ELECTRONIC IN-LINE PUMPS FOR CIRCULATION SYSTEMS

Pumped liquid temperature range: from -10 °C to +140°C - Maximum ambient temperature: +40°C

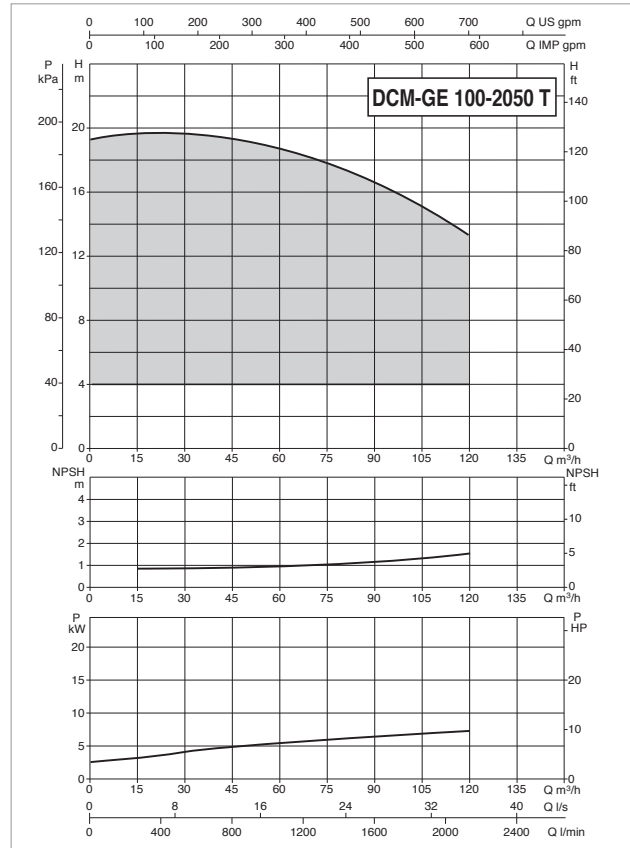
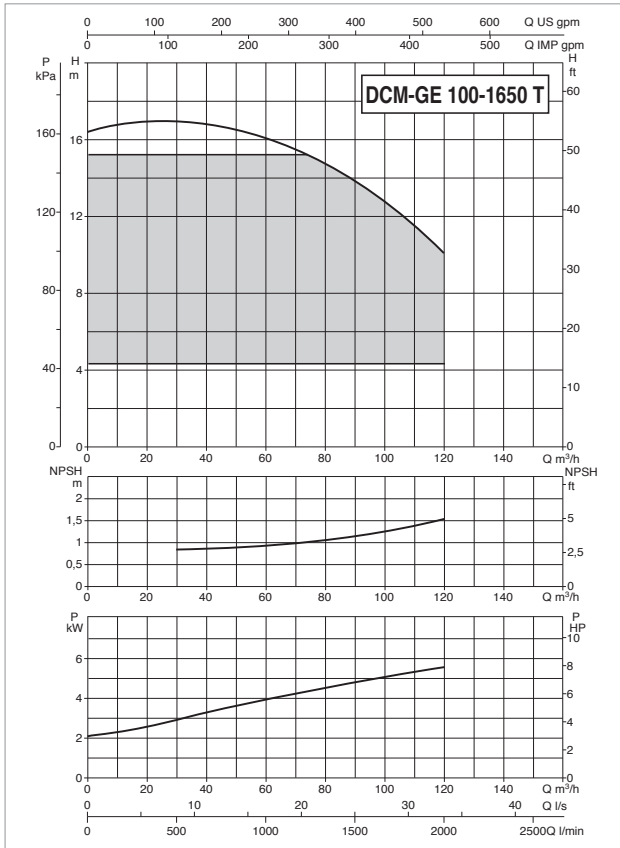

For the MEI index refer to the hydraulic data of the individual pump.

The performance curves are based on kinematic viscosity values = 1 mm²/s and density equal to 1000 kg/m³. Curve tolerance according to ISO 9906.

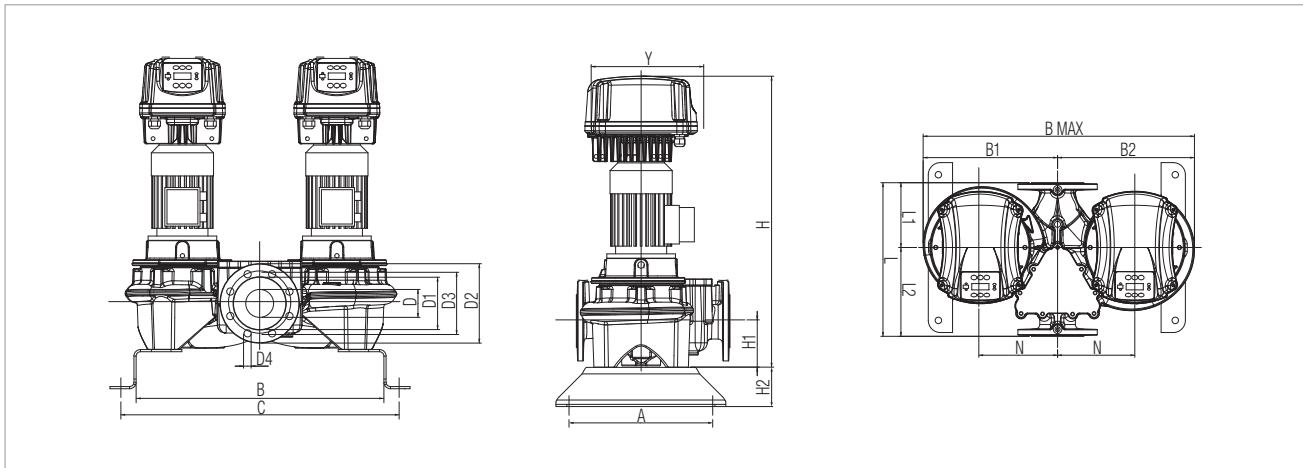

MODEL	ELECTRICAL DATA						
	POWER INPUT 50-60 Hz	POLES	n r.p.m.	P1 MAX kW	P2 NOMINAL		In A
					kW	HP	
DCM-GE 100-1650/A/BAQE/5,5 T MCE 55/C*	3 x 400 V ~	4	1464	7,27	5,5	7,5	10,6
DCM-GE 100-2050/A/BAQE/7,5 T MCE 110/C*	3 x 400 V ~	4	1461	8,89	7,5	10	14,4

* ΔP-v proportional differential pressure adjustment mode also available.

MODEL	A	B	B1	B2	B MAX	C	D	D1	D2	D3	D4	H	H1	H2	L	L1	L2	M	N	Y	DNA	DNM	PACKING DIMENSIONS			VOL. (m ³)	WEIGHT Kg
																							L/A	L/B	H		
DCM-GE 100-1650/A/BAQE/5,5 T MCE 55/C	362	753	430	440	870	833	-	156	220	180	8 HOLES Ø18	1008	140	100	550	221	329	M16	250	352	100	100	550	870	1008	0,48	351
DCM-GE 100-2050/A/BAQE/7,5 T MCE 110/C	500	836	560	575	1135	956	-	156	220	180	Ø18	1132	175	100	670	266	404	M16	300	425	100	100	670	1135	1132	0,86	558

DCM-GE 100 4 POLES - ELECTRONIC IN-LINE PUMPS FOR CIRCULATION SYSTEMS

Pumped liquid temperature range: from -10 °C to +140°C - Maximum ambient temperature: +40°C

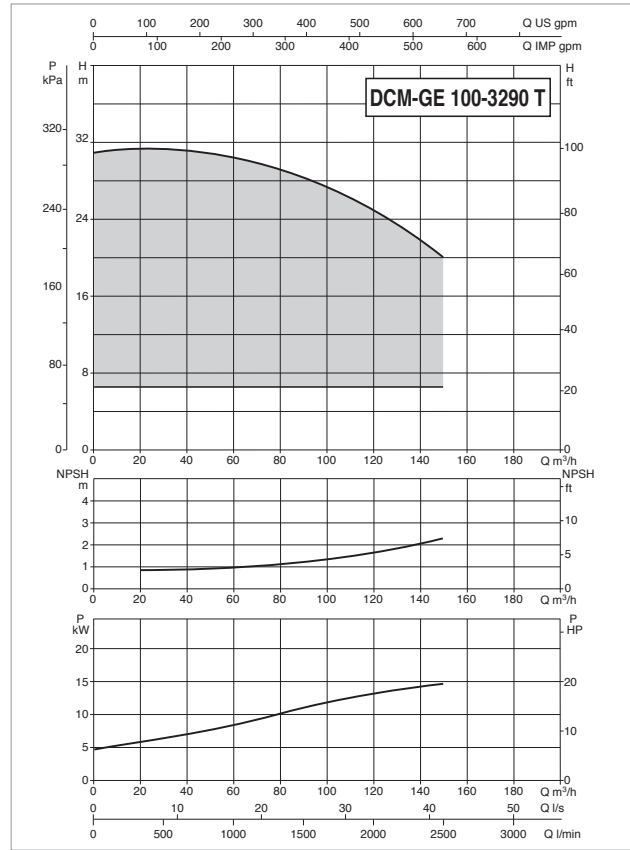
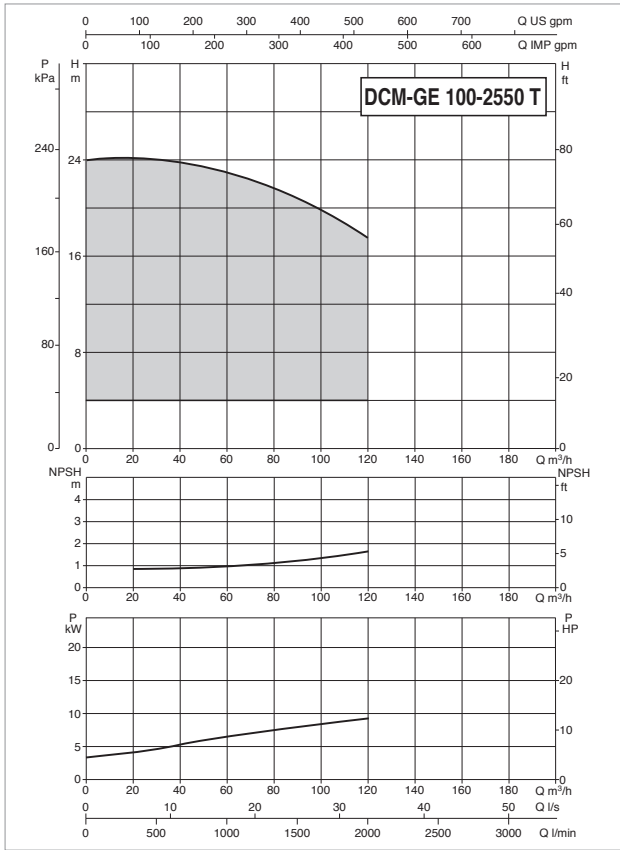

For the MEI index refer to the hydraulic data of the individual pump.

The performance curves are based on kinematic viscosity values = 1 mm²/s and density equal to 1000 kg/m³. Curve tolerance according to ISO 9906.

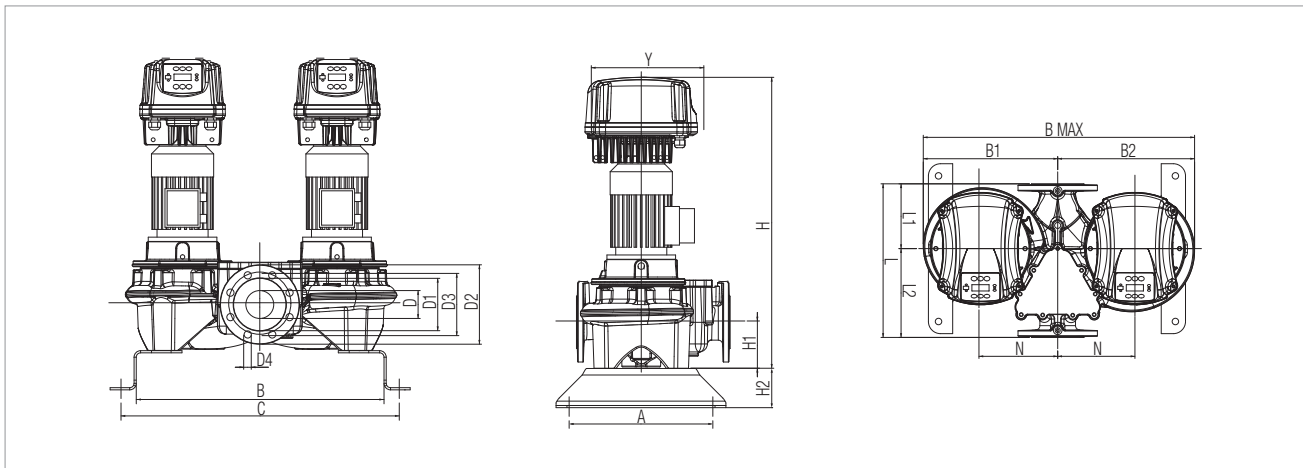

MODEL	ELECTRICAL DATA						
	POWER INPUT 50-60 Hz	POLES	n r.p.m.	P1 MAX kW	P2 NOMINAL		In A
					kW	HP	
DCM-GE 100-2550/A/BAQE/11 T MCE 110/C*	3 x 400 V ~	4	1470	12,74	11	15	22,4
DCM-GE 100-3290/A/BAQE/15 T MCE 150/C*	3 x 400 V ~	4	1471	17,91	15	20	30,5

* ΔP-v proportional differential pressure adjustment mode also available.

MODEL	A	B	B1	B2	B MAX	C	D	D1	D2	D3	D4	H	H1	H2	L	L1	L2	M	N	Y	DNA	DNM	PACKING DIMENSIONS			VOL. (m ³)	WEIGHT Kg
																							L/A	L/B	H		
DCM-GE 100-2550/A/BAQE/11 T MCE 110/C	500	836	560	575	1135	956	-	156	220	180	8 HOLES Ø 18	1237	175	100	670	266	404	M16	300	425	100	100	670	1135	1237	0,94	565
DCM-GE 100-3290/A/BAQE/15 T MCE 150/C	500	836	560	575	1135	956	-	156	220	180	8 HOLES Ø 18	1292	175	100	670	266	404	M16	300	425	100	100	670	1135	1292	0,98	753

DCM-GE 125 4 POLES - ELECTRONIC IN-LINE PUMPS FOR CIRCULATION SYSTEMS

Pumped liquid temperature range: from -10 °C to +140°C - Maximum ambient temperature: +40°C

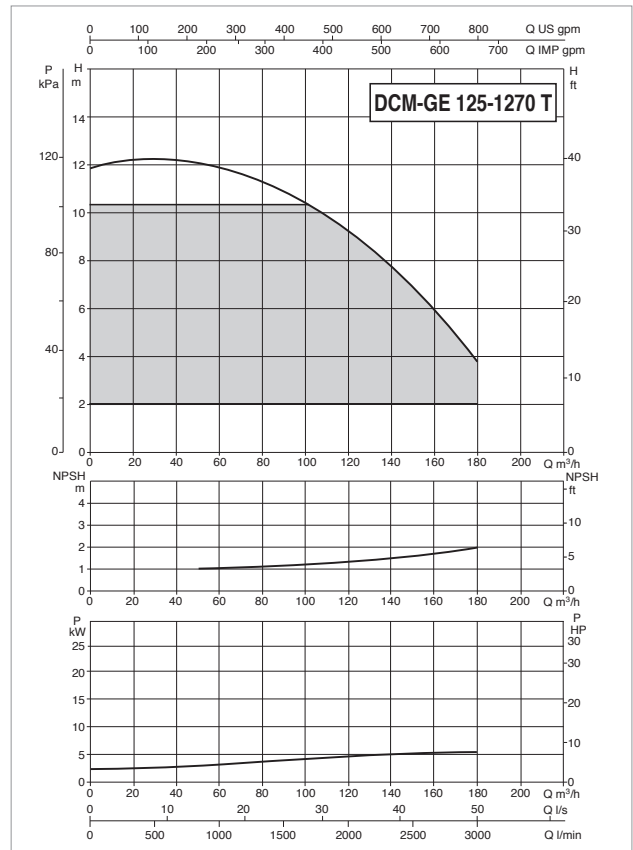
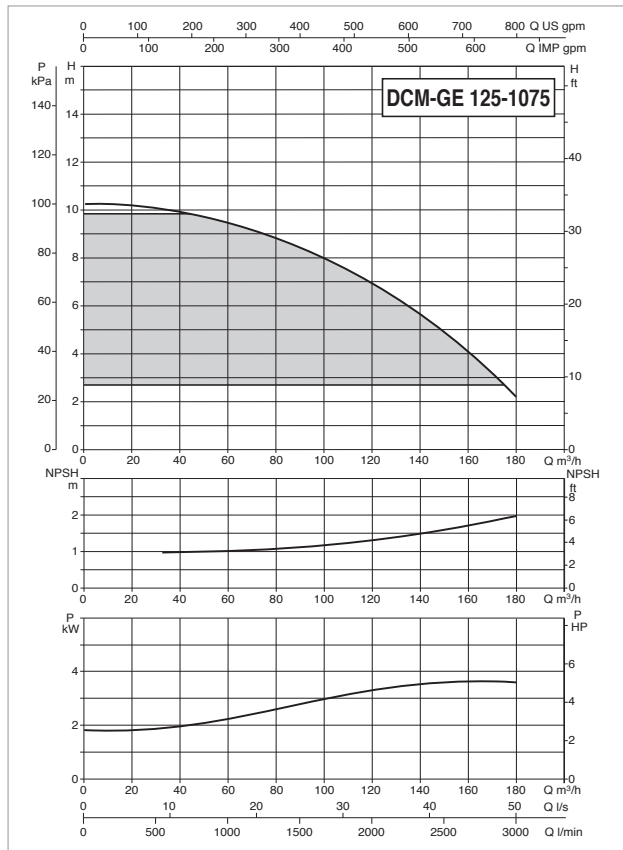

For the MEI index refer to the hydraulic data of the individual pump.

The performance curves are based on kinematic viscosity values = 1 mm²/s and density equal to 1000 kg/m³. Curve tolerance according to ISO 9906.

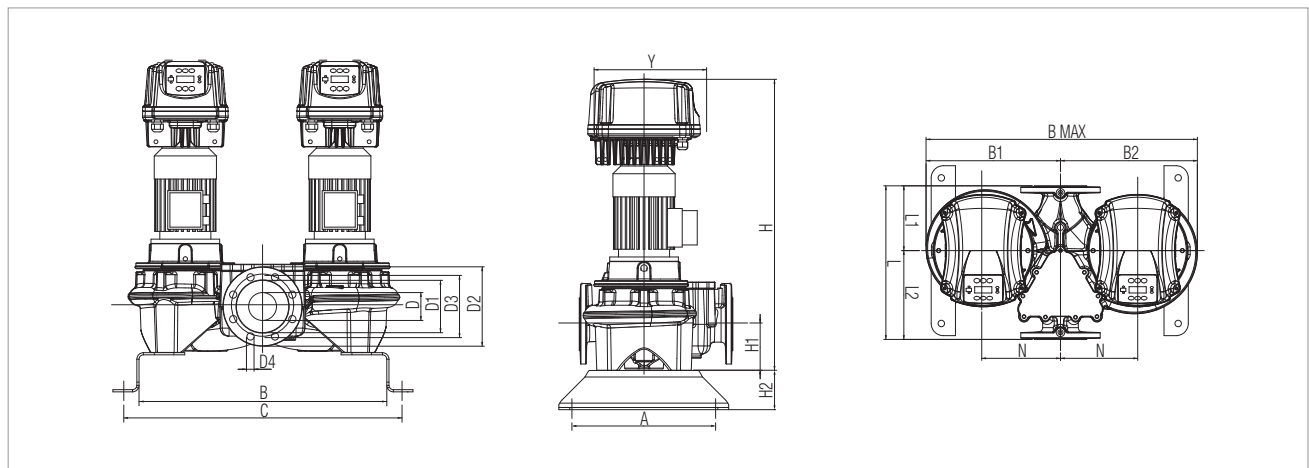

MODEL	ELECTRICAL DATA						
	POWER INPUT 50-60 Hz	POLES	n r.p.m.	P1 MAX kW	P2 NOMINAL		In A
					kW	HP	
DCM-GE 125-1075/A/BAQE/4 T MCE 55/C*	3 x 400 V ~	4	1455	5,38	4	5,5	8,2
DCM-GE 125-1270/A/BAQE/5,5 T MCE 55/C*	3 x 400 V ~	4	1465	7,55	5,5	7,5	10,6

* ΔP-v proportional differential pressure adjustment mode also available.

MODEL	A	B	B1	B2	B MAX	C	D	D1	D2	D3	D4	H	H1	H2	L	L1	L2	M	N	Y	DNA	DNM	PACKING DIMENSIONS			VOL. (m ³)	WEIGHT Kg
																							L/A	L/B	H		
DCM-GE 125-1075/A/BAQE/4 T MCE 55/C	500	810	515	535	1050	930	-	185	250	210	8 HOLES Ø 14	1093	215	100	620	226	394	M16	300	352	125	125	620	1050	1093	0,71	501
DCM-GE 125-1270/A/BAQE/5,5 T MCE 55/C	500	810	515	535	1050	930	-	185	250	210	8 HOLES Ø 14	1089	215	100	620	226	394	M16	300	352	125	125	620	1050	1089	0,71	503

DCM-GE 125 4 POLES - ELECTRONIC IN-LINE PUMPS FOR CIRCULATION SYSTEMS

Pumped liquid temperature range: from -10 °C to +140°C - Maximum ambient temperature: +40°C

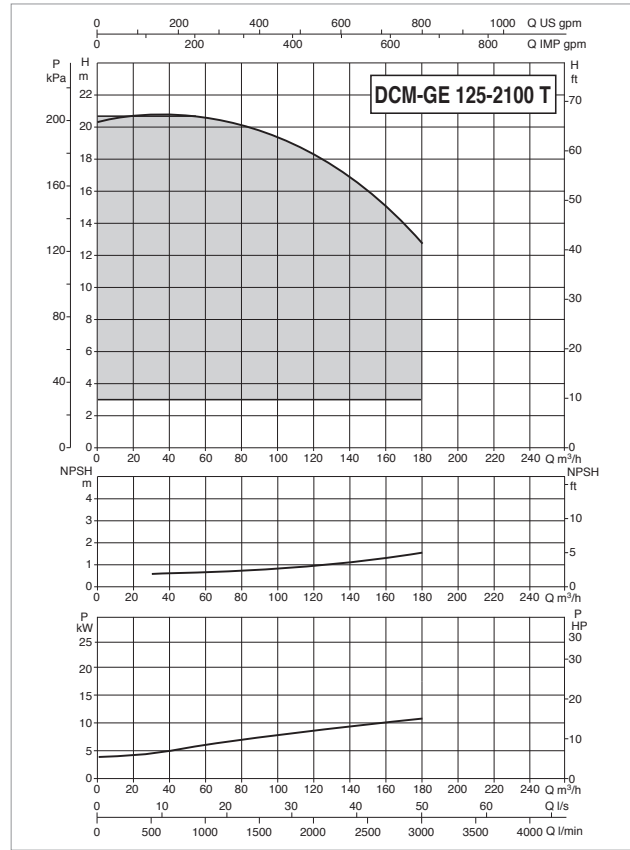
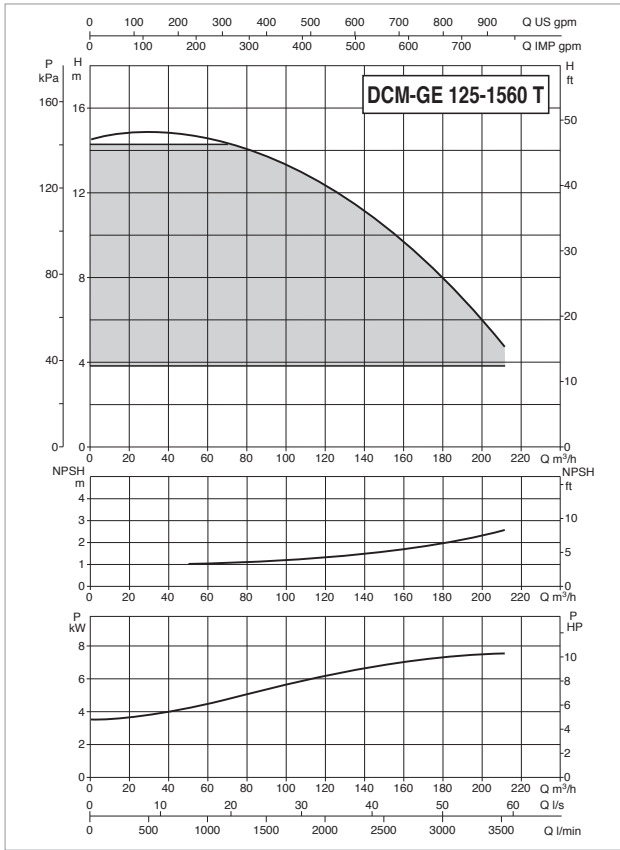

For the MEI index refer to the hydraulic data of the individual pump.

The performance curves are based on kinematic viscosity values = 1 mm²/s and density equal to 1000 kg/m³. Curve tolerance according to ISO 9906.

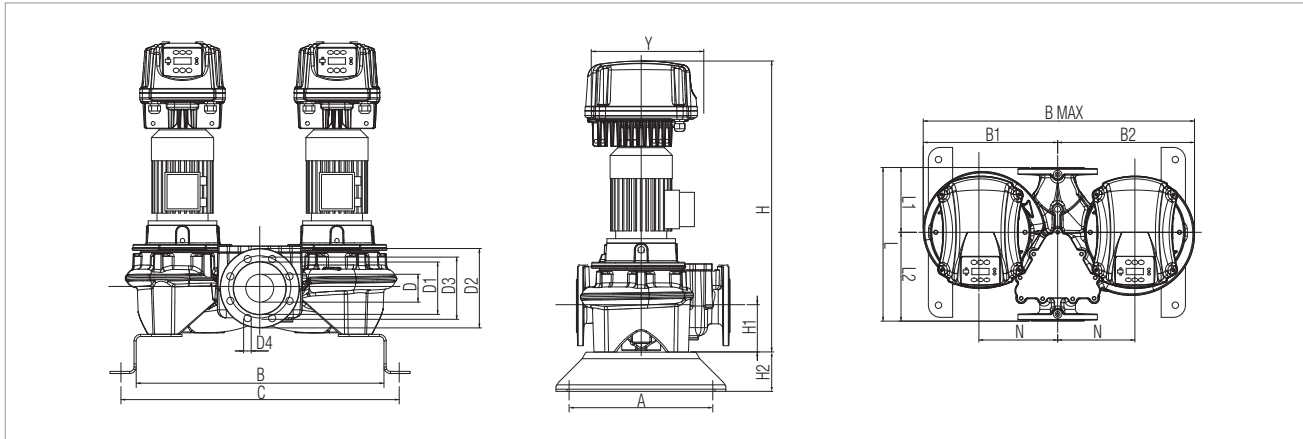

MODEL	ELECTRICAL DATA						
	POWER INPUT 50-60 Hz	POLES	n r.p.m.	P1 MAX kW	P2 NOMINAL		In A
					kW	HP	
DCM-GE 125-1560/A/BAQE/7,5 T MCE 110/C*	3 x 400 V ~	4	1469	9,93	7,5	10	14,4
DCM-GE 125-2100/A/BAQE/11 T MCE 110/C	3 x 400 V ~	4	1475	14,3	11	15	22,4

* ΔP-v proportional differential pressure adjustment mode also available.

MODEL	A	B	B1	B2	B MAX	C	D	D1	D2	D3	D4	H	H1	H2	L	L1	L2	M	N	Y	DNA/DNM	PACKING DIMENSIONS			VOL. (m ³)	WEIGHT Kg	
																						L/A	L/B	H			
DCM-GE 125-1560/A/BAQE/7,5 T MCE 110/C	500	810	515	535	1050	930	-	185	250	210	8 HOLES Ø 14	1177	215	100	620	226	394	M16	300	425	125	125	620	1050	1177	0,77	538
DCM-GE 125-2100/A/BAQE/11 T MCE 110/C	500	810	555	571	1126	930	-	185	250	210	8 HOLES Ø 14	1297	215	100	800	316	484	M16	300	425	125	125	800	1126	1297	1,17	768

DCM-GE 125 4 POLES - ELECTRONIC IN-LINE PUMPS FOR CIRCULATION SYSTEMS

Pumped liquid temperature range: from -10 °C to +140°C - Maximum ambient temperature: +40°C

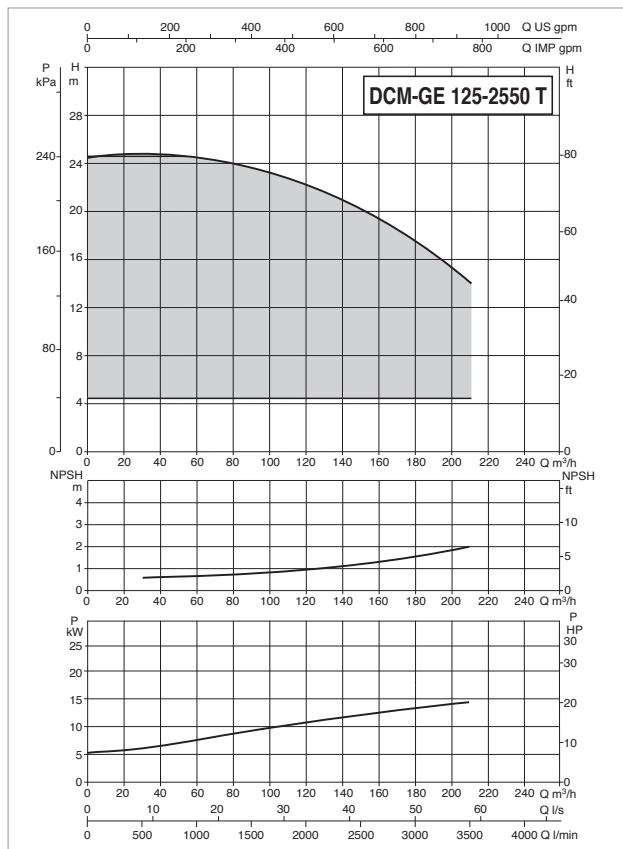

For the MEI index refer to the hydraulic data of the individual pump.

The performance curves are based on kinematic viscosity values = 1 mm²/s and density equal to 1000 kg/m³. Curve tolerance according to ISO 9906.

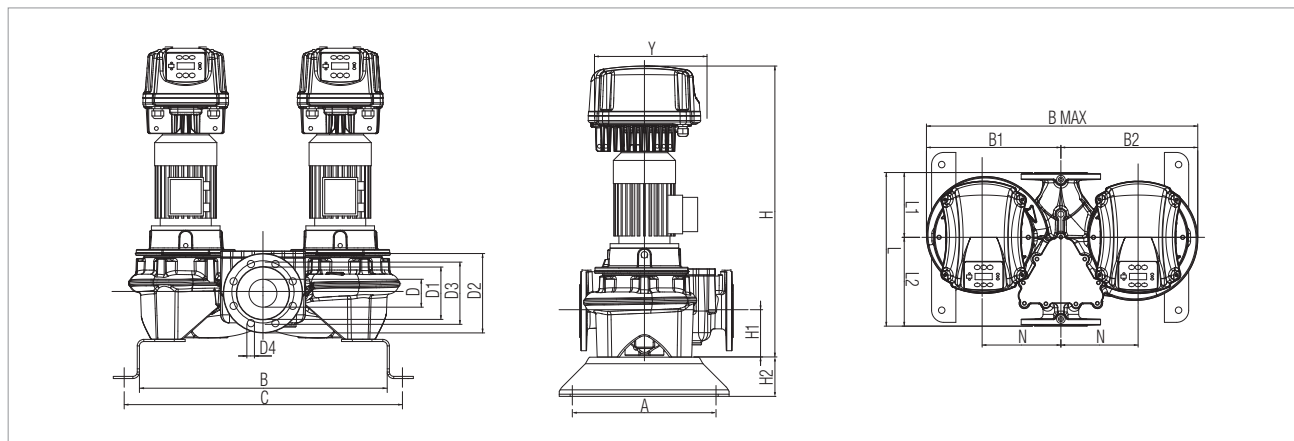

MODEL	ELECTRICAL DATA						
	POWER INPUT 50-60 Hz	POLES	n r.p.m.	P1 MAX kW	P2 NOMINAL		In A
					kW	HP	
DCM-GE 125-2550/A/BAQE/15 T MCE 150/C*	3 x 400 V ~	4	1470	17,07	15	20	30,5

* ΔP-v proportional differential pressure adjustment mode also available.

MODEL	A	B	B1	B2	B MAX	C	D	D1	D2	D3	D4	H	H1	H2	L	L1	L2	M	N	Y	DNA	DNM	PACKING DIMENSIONS			VOL. (m ³)	WEIGHT Kg
																							L/A	L/B	H		
DCM-GE 125-2550/A/BAQE/15 T MCE 150/C	500	810	555	571	1126	930	-	185	250	210	8 HOLES Ø 14	1352	215	100	800	316	484	M16	300	425	125	125	800	1126	1352	1,22	880

DCM-GE 150 4 POLES - ELECTRONIC IN-LINE PUMPS FOR CIRCULATION SYSTEMS

Pumped liquid temperature range: from -10 °C to +140°C - Maximum ambient temperature: +40°C

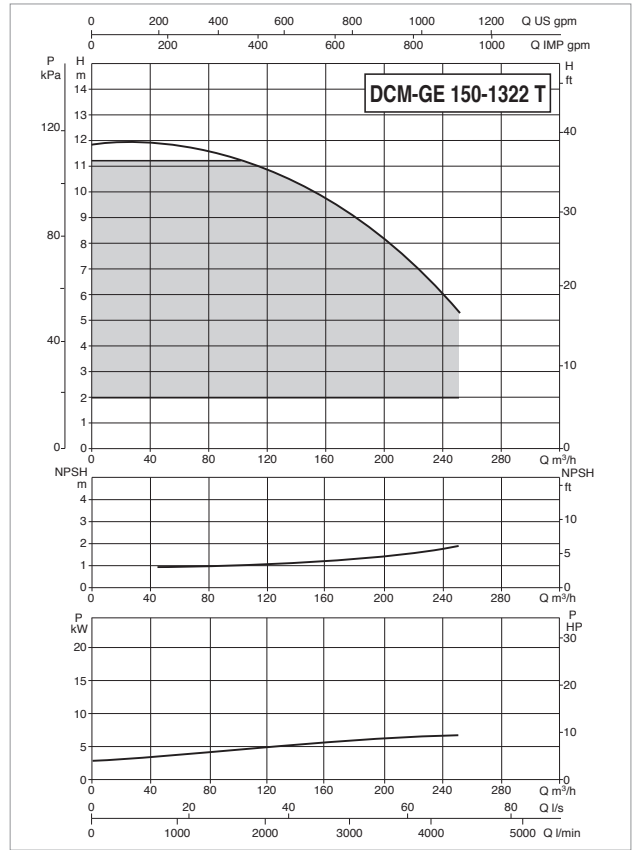
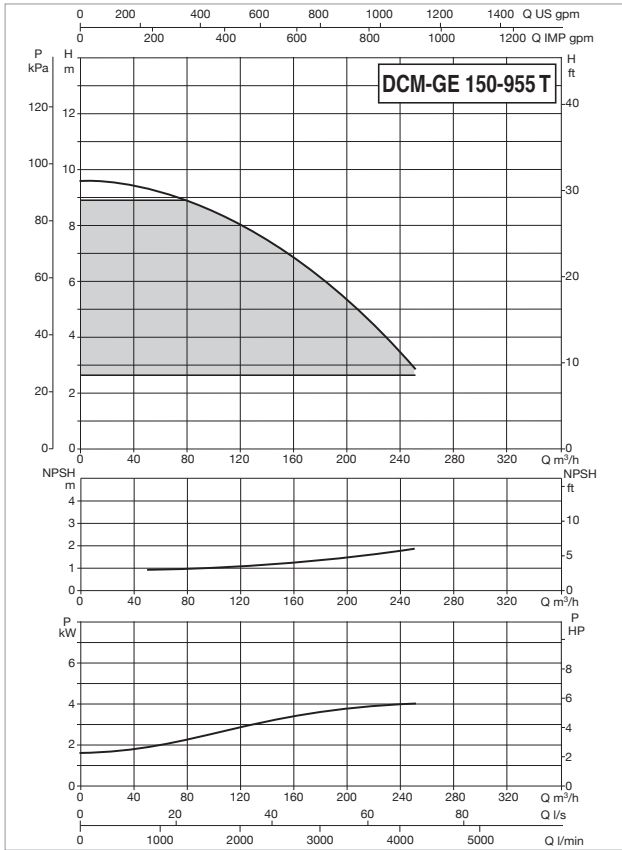

For the MEI index refer to the hydraulic data of the individual pump.

The performance curves are based on kinematic viscosity values = 1 mm²/s and density equal to 1000 kg/m³. Curve tolerance according to ISO 9906.

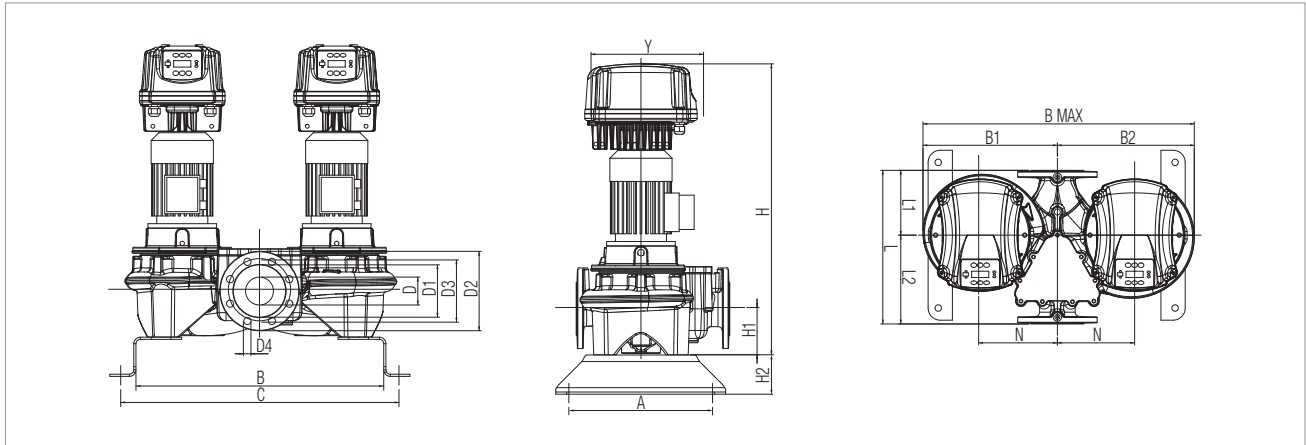

MODEL	ELECTRICAL DATA						
	POWER INPUT 50-60 Hz	POLES	n r.p.m.	P1 MAX kW	P2 NOMINAL		In A
					kW	HP	
DCM-GE 150-955/A/BAQE/5,5 T MCE 55/C*	3 x 400 V ~	4	1460	7,55	5,5	7,5	10,6
DCM-GE 150-1322/A/BAQE/7,5 T MCE 110/C	3 x 400 V ~	4	1460	9,86	7,5	10	14,4

MODEL	A	B	B1	B2	B MAX	C	D	D1	D2	D3	D4	H	H1	H2	L	L1	L2	M	N	Y	DNA/DNM	PACKING DIMENSIONS L/A L/B H	VOL. (m ³)	WEIGHT Kg	
DCM-GE 150-955/A/BAQE/5,5 T MCE 55/C	500	805	550	580	1130	925	-	210	285	240	8 HOLES Ø 22	1112	215	100	800	296	504	M16	300	352	150	150	800 1130 1112	1,01	658
DCM-GE 150-1322/A/BAQE/7,5 T MCE 110/C	500	805	550	580	1130	925	-	210	285	240	8 HOLES Ø 22	1200	215	100	800	296	504	M16	300	425	150	150	800 1130 1200	1,08	693

DCM-GE 150 4 POLES - ELECTRONIC IN-LINE PUMPS FOR CIRCULATION SYSTEMS

Pumped liquid temperature range: from -10 °C to +140°C - Maximum ambient temperature: +40°C

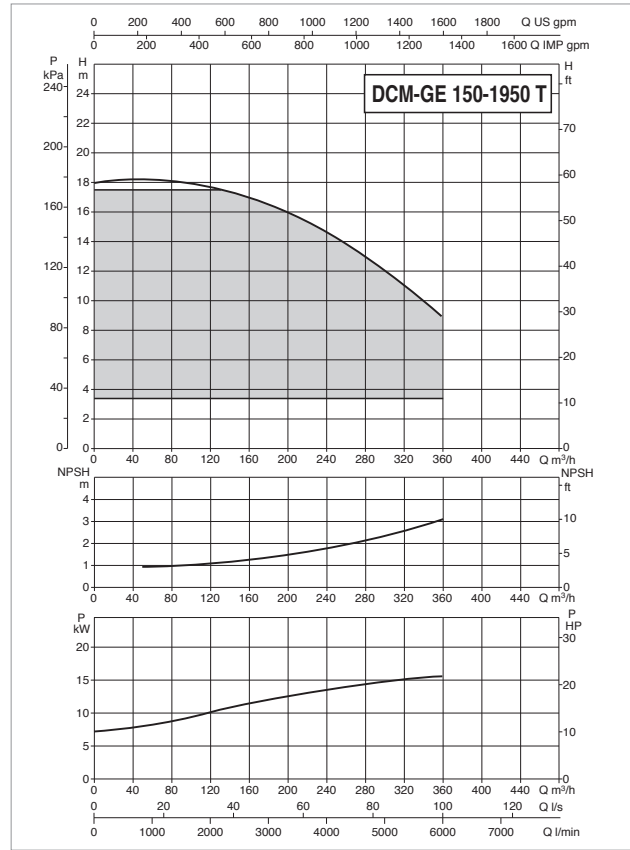
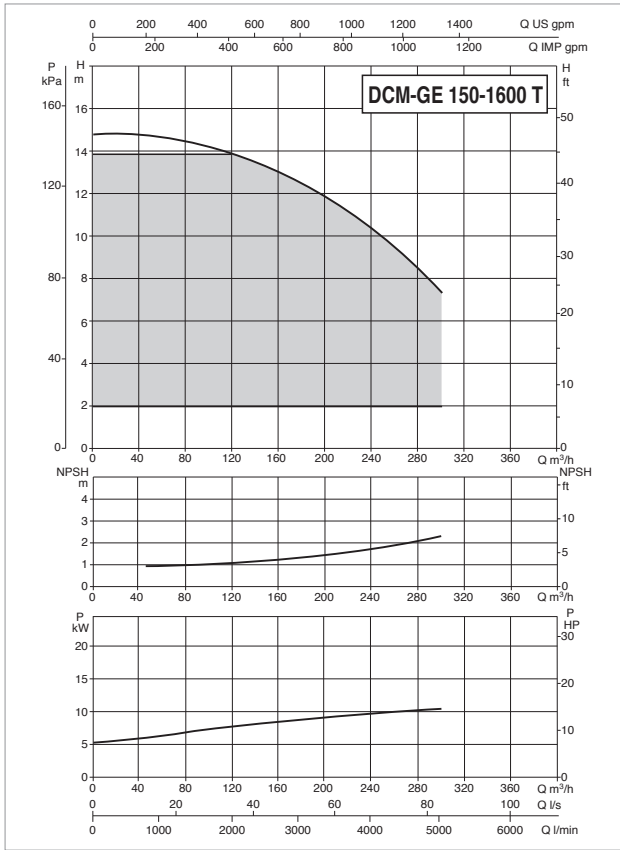

For the MEI index refer to the hydraulic data of the individual pump.

The performance curves are based on kinematic viscosity values = 1 mm²/s and density equal to 1000 kg/m³. Curve tolerance according to ISO 9906.

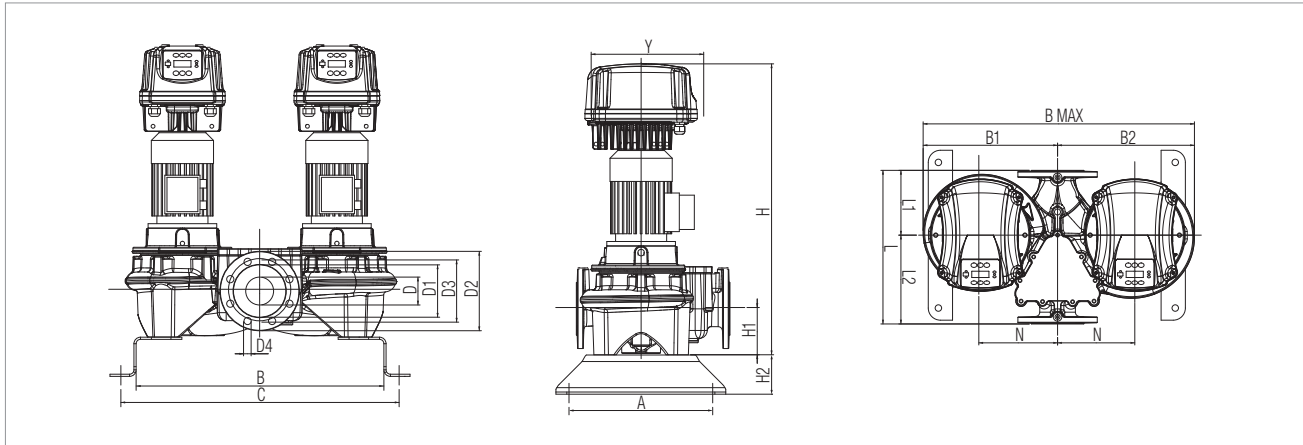

MODEL	ELECTRICAL DATA						
	POWER INPUT 50-60 Hz	POLES	n r.p.m.	P1 MAX kW	P2 NOMINAL		In A
					kW	HP	
DCM-GE 150-1600/A/BAQE/11 T MCE 110/C*	3 x 400 V ~	4	1450	14,97	11	15	22,4
DCM-GE 150-1950/A/BAQE/15 T MCE 150/C*	3 x 400 V ~	4	1470	19,31	15	20	30,5

* ΔP-v proportional differential pressure adjustment mode also available.

MODEL	A	B	B1	B2	B MAX	C	D	D1	D2	D3	D4	H	H1	H2	L	L1	L2	M	N	Y	DNA	DNM	PACKING DIMENSIONS			VOL. (m ³)	WEIGHT Kg
																							L/A	L/B	H		
DCM-GE 150-1600/A/BAQE/11 T MCE 110/C	500	805	550	580	1130	925	-	210	285	240	8 HOLES ∅ 22	1305	215	100	800	296	504	M16	300	425	150	150	800	1130	1305	1,18	719
DCM-GE 150-1950/A/BAQE/15 T MCE 150/C	500	805	550	580	1130	925	-	210	285	240	∅ 22	1360	215	100	800	296	504	M16	300	425	150	150	800	1130	1360	1,23	818