

CP2E, CP2-GE / DCP2E, DCP2-GE

ELECTRONIC IN-LINE PUMPS



TECHNICAL DATA

Operating range: up to 105 m³/h

Head: up to 110 m

Type of pumped liquid: clean, free of solids and abrasives, non-viscous, non-aggressive, non-crystallised and chemically neutral, with properties similar to water

Glycol percentage (maximum): 50%

Liquid temperature range: from -15 °C to +140 °C

Maximum ambient temperature: +50 °C

Maximum operating pressure: 1600 kPa / 16 bar

Flanging or threading: flanging PN 10/PN16

Motor efficiency: IE5 up to 2,2 kW; IE3 ≥ 0,75 kW

Motor protection class: IP 55

Motor insulation class: F

Impeller material: cast iron or technopolymer

Three phase power input: 3x230 V 50 Hz / 3x400 V 50 Hz

Max rpm: 2910 rpm

Type of installation: Fixed in horizontal or vertical position with motor in up position. Only in vertical position for motor from 7,5 kW.

APPLICATIONS

Circulation pumps with inline ports, suitable for use in heating and air-conditioning, refrigeration and domestic hot water systems. The use of the NgDrive variable frequency drive makes this a particularly versatile unit by ensuring that performance is automatically adjusted to match the system's different requirements, at the same time maintaining constant differential pressures. They come in single and twin-head versions.

CONSTRUCTION FEATURES OF THE PUMP

PN10 or PN16 flanged inlet and outlet with threaded holes for control pressure gauges. Cast iron pump casing and motor mount, cast iron or technopolymer impeller depending on the model. AISI 316 motor shaft. Mechanical seal with silicon carbide stationary face and rotating face.

CONSTRUCTION FEATURES OF THE MOTOR

IE5-rated permanent magnet motor on models up to 2.2 kW paired with NgDrive to achieve the highest possible efficiency rating. IE3 motor paired with NgDrive on 3kW models and up.

CONSTRUCTION FEATURES OF THE ELECTRONIC

The inline motor-driven pumps are controlled using NgDrive, the variable-speed control unit designed to adapt performance to match the system's actual requirements, with a resulting reduction in power demand along with energy savings. The gradual motor speed adjustment decreases the potential for component wear and protects the pump from water hammer.

The graphic display makes the unit easy to read and simplifies the process of entering operation settings; system setup is also very simple thanks to the relevant wizard.

The design has been developed to facilitate installation and maintenance are straightforward: it is easy to handle; it can be mounted on a wall or on the pump in 5 different positions; and it is split into two parts so that the various components inside can be mounted and serviced separately. It delivers efficiency, energy savings, and is supremely user friendly.

CP2E, CP2-GE / DCP2E, DCP2-GE

ELECTRONIC IN-LINE PUMPS

MATERIALS

N.	PARTS	MATERIALS
1	PUMP BODY	CAST IRON EN G.JL250 UNI EN 1561
2	SUPPORT	CAST IRON EN G.JL250 UNI EN 1561
3	IMPELLER	CAST IRON EN G.JL200 UNI EN 1561 AND ULTRASON E 2010
4	SHAFT WITH ROTOR	AISI 316
5	MECHANICAL SEAL	SPRING AISI 316 - SIC / SIC - EPDM
6	O-RING	EPDM

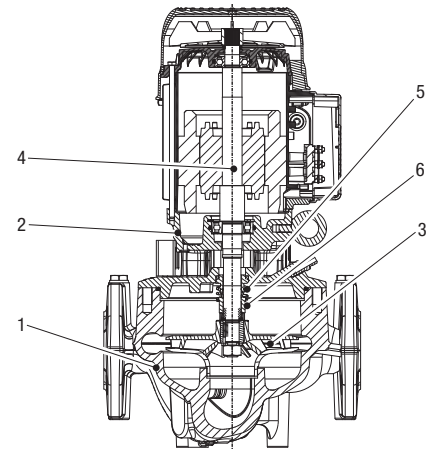

Denominations: (example)

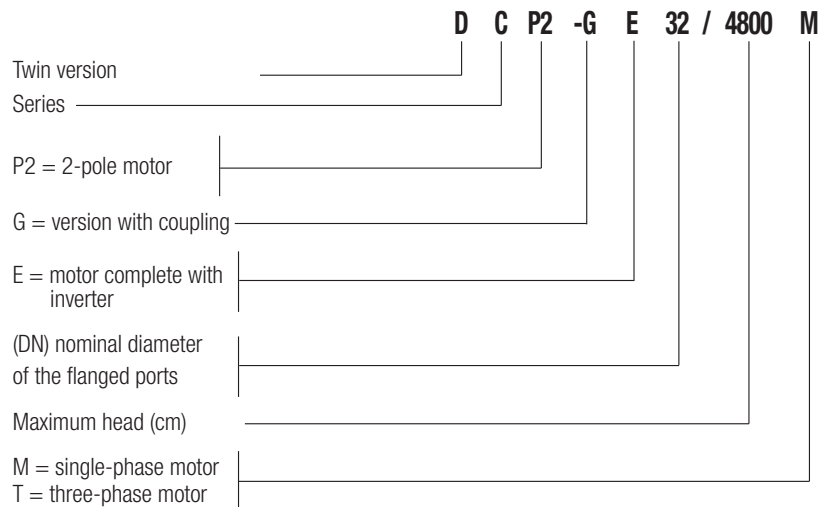

CONSTRUCTION FEATURES ELECTRICAL SECTION

NGDRIVE

The technological product of over 40 years' experience in the water handling sector. NgDrive is not just a variable frequency drive, it is the hardware component of a fully-fledged smart system, conceived to cater to the needs of its users, not least in its design.

VERSATILITY and EASE of use make NgDrive the most comprehensive controller available in the market. A new generation of variable frequency drives, designed for the control and protection of circulation and pressure booster pumps, adjusting them to suit the system's actual demands, thus resulting in both occupant comfort and real energy savings.

With cutting-edge TECHNOLOGIES and the DAB group's lengthy experience, NgDrive features a meticulously engineered design that is not just design for design's sake; instead, it was conceived specifically to cater to the needs of its users. Moreover, it is split into two parts that can be separated so that the components inside can even be fitted at different times and serviced without disconnecting any wires.

With the option of being fitted on the actual pump or wall mounted, NgDrive gives you the tool you need to get the most out of the DAB range of pumps and use them in the most efficient way. NgDrive has been designed and built to offer the best user experience: easy to install, set up and monitor.

- 2.8" TFT colour display

- A single software for different applications (circulation and pressure boosting)
- Keypad with intuitive commands
- Setup and getting started wizards
- Software updates via app
- Integrated connectivity (Wi-fi, Bluetooth, Wireless, Modbus) for remote control

NgDrive introduces new standards in DAB technology: cooling via built-in fan with speed control based on temperature, and architecture with four microprocessors:

- Wireless communication
- Pump functions managed via display
- Motor control
- Input and output signals

Between two and a maximum of six variable frequency drives can be connected wirelessly.

OPERATING MODES

NgDrive can be used to control pumps both for pressure boosting and circulation systems. Constant-pressure control is the method used for pressure boosting applications, while for circulation, the control options are as follows:

- Constant speed
- Constant differential temperature
- Constant temperature
- Proportional differential pressure
- Constant differential pressure

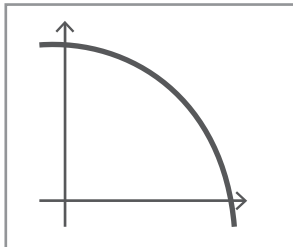

Constant speed

The speed of rotation is kept at a constant rpm. This speed can be set in a range from a minimum value to the circulation pump's nominal frequency. This mode can be set via the control panel.

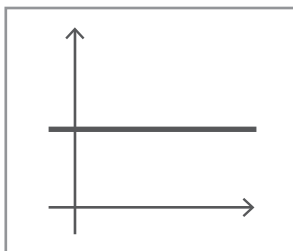

Constant differential pressure

The maximum head is constant, regardless of the water demand. This mode can be set via the control panel, where you can specify the pressure setpoint and, where applicable, the liquid temperature dependence (in this case, you will need to connect a T1 and T2 sensor).

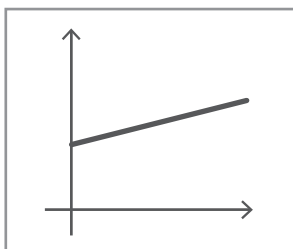

Proportional differential pressure

In this control mode, the differential pressure is reduced or increased as water demand drops or rises. This mode can be set via the control panel, where you can specify the pressure setpoint and, where applicable, the liquid temperature dependence (in this case, you will need to connect a T1 and T2 sensor).

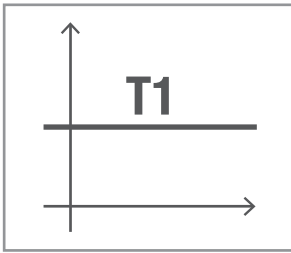

Constant temperature

With this function, the circulation pump increases or decreases flow rate to keep constant the temperature measured by the NTC sensor connected.

You can set 2 operating modes:

- T1 increase mode → if the desired temperature (T_s) is greater than the temperature measured (T_1), the circulation pump increases flow rate until the temperature reaches T_s .
- T1 decrease mode → if the desired temperature (T_s) is greater than the temperature measured (T_1), the circulation pump decreases flow rate until the temperature reaches T_s

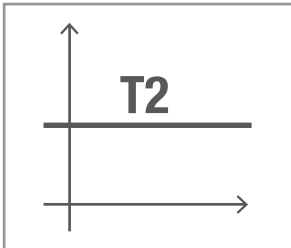

Constant temperature

With this function, the circulation pump increases or decreases flow rate to keep constant the temperature measured by the NTC sensor connected.

You can set 2 operating modes:

- T2 increase mode → if the desired temperature (T_s) is lower than the temperature measured (T_1), the circulation pump increases flow rate until the temperature reaches T_s .
- T1 decrease mode → if the desired temperature (T_s) is greater than the temperature measured (T_1), the circulation pump decreases flow rate until the temperature reaches T_s .

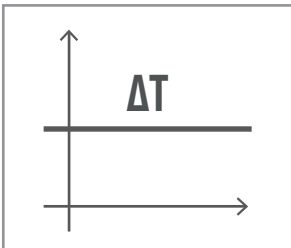

Constant temperature difference

With this function, the circulation pump increases or decreases flow rate to keep constant the T1-T2 temperature difference as an absolute value. This mode can be set via the control panel, where you can specify the temperature setpoint.

CP2E, CP2-GE / DCP2E, DCP2-GE

ELECTRONIC IN-LINE PUMPS

SELECTION TABLE - CP2E

MODEL	HYDRAULIC DATA						
	Q=m ³ /h	0	10	15	20	30	35
	Q=l/min	0	167	250	333	500	583
CP2E 32-1400 IE5	H (m)	14,2	12,6	11,1	9,0		
CP2E 32-1800 IE5		17,8	16,4	14,8	12,6	6,3	
CP2E 32-2100 IE5		22,7	17,6	10,0			
CP2E 32-2200 IE5		22,5	21,3	19,7	17,3	10,5	5,9
CP2E 32-2700 IE5		26,7	26,2	24,8	22,8	17,1	13,3
CP2E 32-3600 IE3		36,4	35,5	33,5	31,0	24,8	
CP2E 32-4000 IE3		40,3	39,4	37,4	34,9	28,4	24,5
CP2-GE 32-4800 IE3		48,7	48,1	46,5	44,2	37,9	33,8

SELECTION TABLE - DCP2E

MODEL	HYDRAULIC DATA						
	Q=m ³ /h	0	10	15	20	30	35
	Q=l/min	0	167	250	333	500	583
DCP2E 32-1400 IE5	H (m)	14,2	12,3	10,3	7,2		
DCP2E 32-1800 IE5		17,6	15,9	13,8	10,8	1,5	
DCP2E 32-2100 IE5		23,0	17,3	9,1			
DCP2E 32-2200 IE5		22,8	21,4	19,3	16,1	6,5	0,4
DCP2E 32-2700 IE5		27,0	25,7	24,3	22,1	16,4	12,6
DCP2E 32-3600 IE3		36,9	35,0	33,1	30,4	22,6	
DCP2E 32-4000 IE3		40,9	39,1	37,0	34,1	25,9	21,0
DCP2-GE 32-4800 IE3		49,4	47,8	46,2	43,7	34,9	28,9

CP2E, CP2-GE / DCP2E, DCP2-GE

ELECTRONIC IN-LINE PUMPS

SELECTION TABLE - CP2E

MODEL	HYDRAULIC DATA								
	Q=m ³ /h	0	10	15	20	30	40	50	70
	Q=l/min	0	167	250	333	500	667	833	1167
CP2E 40-1900 IE5	H (m)	19,1	19,4	19,3	18,4	13,9	7,4		
CP2E 40-2200 IE5		22,3	22,8	22,4	21,7	19,2	15,5		
CP2E 40-2800 IE3		27,6	27,8	27,2	26,3	23,5	19,8		
CP2E 40-3300 IE3		33,1	33,5	32,9	32,0	29,2	25,3		
CP2-GE 40-4000 IE3		38,5	39,0	38,9	38,3	35,7	30,9		
CP2-GE 40-5000 IE3		48,8	49,2	49,0	48,6	46,9	44,3		
CP2-GE 40-6600 IE3		66,2	66,4	66,1	65,6	63,6	60,5		
CP2-GE 40-8200 IE3		82,0	82,1	81,8	81,2	78,9	74,9	69,1	52,9

SELECTION TABLE - DCP2E

MODEL	HYDRAULIC DATA								
	Q=m ³ /h	0	10	15	20	30	40	50	70
	Q=l/min	0	167	250	333	500	667	833	1167
DCP2E 40-1900 IE5	H (m)	19,0	19,2	18,7	17,7	14,4	9,0		
DCP2E 40-2200 IE5		22,9	23,5	23,0	22,2	19,2	14,5		
DCP2E 40-2800 IE3		27,7	28,2	27,9	27,1	24,1	19,2		
DCP2E 40-3300 IE3		33,4	33,9	33,5	32,8	29,9	25,2		
DCP2-GE 40-4000 IE3		39,2	39,5	39,4	38,9	36,3	31,1		
DCP2-GE 40-5000 IE3		49,3	49,4	49,0	48,4	45,9	41,7		
DCP2-GE 40-6600 IE3		67,9	67,6	67,0	66,2	63,3	58,7		
DCP2-GE 40-8200 IE3		83,4	84,3	83,8	82,7	79,2	74,1	67,4	46,1

CP2E, CP2-GE / DCP2E, DCP2-GE

ELECTRONIC IN-LINE PUMPS

SELECTION TABLE - CP2E

MODEL	HYDRAULIC DATA								
	Q=m ³ /h	0	10	20	30	40	50	60	70
	Q=l/min	0	167	250	333	500	667	833	1167
CP2E 50-800 IE5	H (m)	8,0	7,7	6,5	4,6				
CP2E 50-1100 IE5		11,3	11,2	10,5	9,0	6,7	4,0	1,3	
CP2E 50-1400 IE5		14,1	14,2	13,8	12,6	10,7	7,9	4,3	
CP2E 50-1800 IE5		17,4	17,8	17,5	16,5	14,8	12,4	9,1	
CP2E 50-2100 IE3		21,4	21,8	21,4	20,1	18,1	15,3	11,6	6,8
CP2E 50-2800 IE3		27,9	27,6	26,6	24,9	22,4	19,1	15,2	10,5
CP2-GE 50-3300 IE3		33,8	33,9	33,0	31,2	28,6	25,2	21,1	16,1
CP2-GE 50-4400 IE3		43,7	44,0	43,2	41,5	38,8	35,1	30,5	25,0
CP2-GE 50-5200 IE3		52,0	53,2	52,9	51,7	49,8	47,3	44,2	40,6
CP2-GE 50-6600 IE3		65,5	67,2	66,8	65,2	62,9	60,3	57,6	54,5

SELECTION TABLE - DCP2E

MODEL	HYDRAULIC DATA								
	Q=m ³ /h	0	10	20	30	40	50	60	70
	Q=l/min	0	167	250	333	500	667	833	1167
DCP2E 50-800 IE5	H (m)	8,1	7,7	6,1	4,0				
DCP2E 50-1100 IE5		11,4	11,2	10,1	8,1	5,5			
DCP2E 50-1400 IE5		14,7	14,5	13,7	12,1	9,6	6,4	2,5	
DCP2E 50-1800 IE5		17,4	17,5	16,9	15,6	13,4	10,2	5,9	
DCP2E 50-2100 IE3		22,1	22,4	21,7	20,1	17,8	14,6	10,5	5,2
DCP2E 50-2800 IE3		28,6	28,1	26,9	24,8	21,7	17,6	12,5	6,7
DCP2-GE 50-3300 IE3		34,6	34,5	33,5	31,5	28,4	24,3	19,2	12,9
DCP2-GE 50-4400 IE3		44,3	44,5	43,7	41,9	38,8	34,5	29,0	22,5
DCP2-GE 50-5200 IE3		53,3	54,1	53,7	52,4	50,1	47,1	43,3	38,8
DCP2-GE 50-6600 IE3		67,2	68,8	68,4	66,8	64,4	61,5	58,2	54,4

CP2E - ELECTRONIC IN-LINE PUMPS

Liquid temperature range: from -15°C up to 140°C - Maximum operating pressure: 16 bar (1600 kPa)

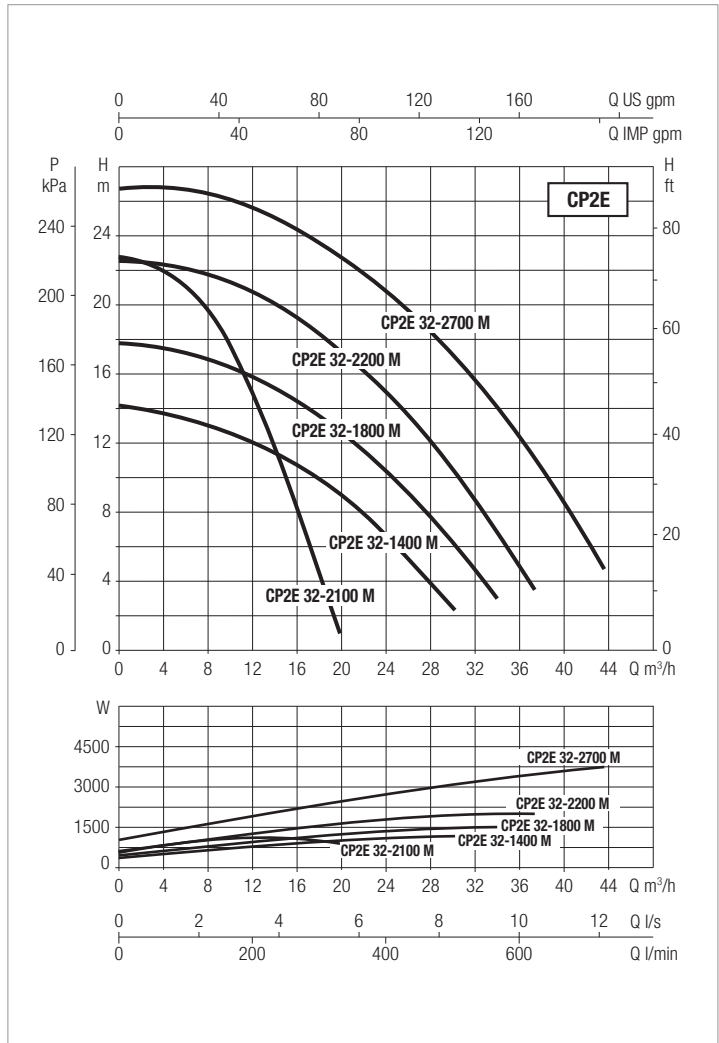
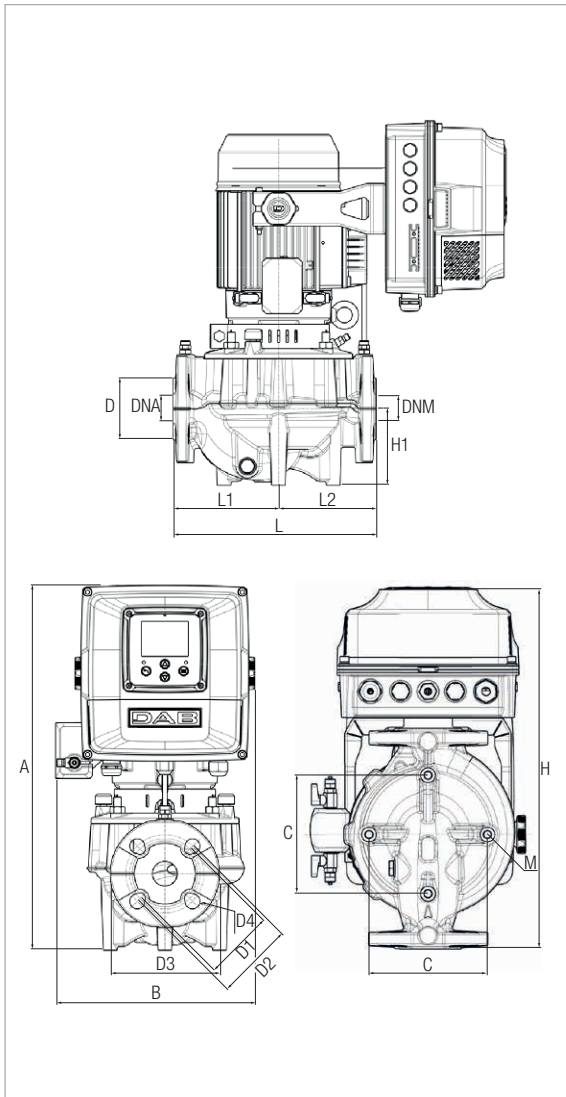

The performance curves are based on kinematic viscosity values = 1 mm²/s and density equal to 1000 kg/m³. Curve tolerance according to ISO 9906.

MODEL	ELECTRICAL DATA							
	CENTRE DISTANCE	PUMP CONNECTIONS	POWER INPUT 50 HZ	P1 MAX [kW]	P2 NOMINAL		In [A]	
					kW	HP	230 V	400 V
CP2E 32-1400 IE5	260	DN 32 PN 16 DN 32 PN 10	230 V	0,93	0,7	0,9	5,1	-
CP2E 32-1800 IE5				1,5	1,1	1,5	6,64	-
CP2E 32-2100 IE5				1,13	0,7	0,9	5	-
CP2E 32-2200 IE5				2	1,5	2	8,8	-
CP2E 32-2700 IE5	320		400 V	3,4	2,2	3	-	5,3

MODEL	A	B	C	D	D1	D2	D3	D4	H	H1	L	L1	L2	M	DNA	DNM	PACKING DIMENSIONS			VOLUME (mc)	WEIGHT Kg
																	L/A	L/B	H		
CP2E 32-1400 IE5	467	255	140	78	90	100	141	19	426	98	260	135	125	10	32	32	600	300	640	0,12	31
CP2E 32-1800 IE5	537	256	140	78	90	100	140	19	430	98	260	135	125	10	32	32	600	300	640	0,12	31
CP2E 32-2100 IE5	467	255	140	78	90	100	141	19	426	98	260	135	125	10	32	32	600	300	640	0,12	31
CP2E 32-2200 IE5	537	256	140	78	90	100	140	19	430	98	260	135	125	10	32	32	600	300	640	0,12	31
CP2E 32-2700 IE5	537	256	180	79	90	100	140	19	460	90	320	165	155	10	32	32	600	300	640	0,12	41,5

CP2E, CP2-GE - ELECTRONIC IN-LINE PUMPS

Liquid temperature range: from -15°C to +140°C - Maximum operating pressure: 16 bar (1600 kPa)

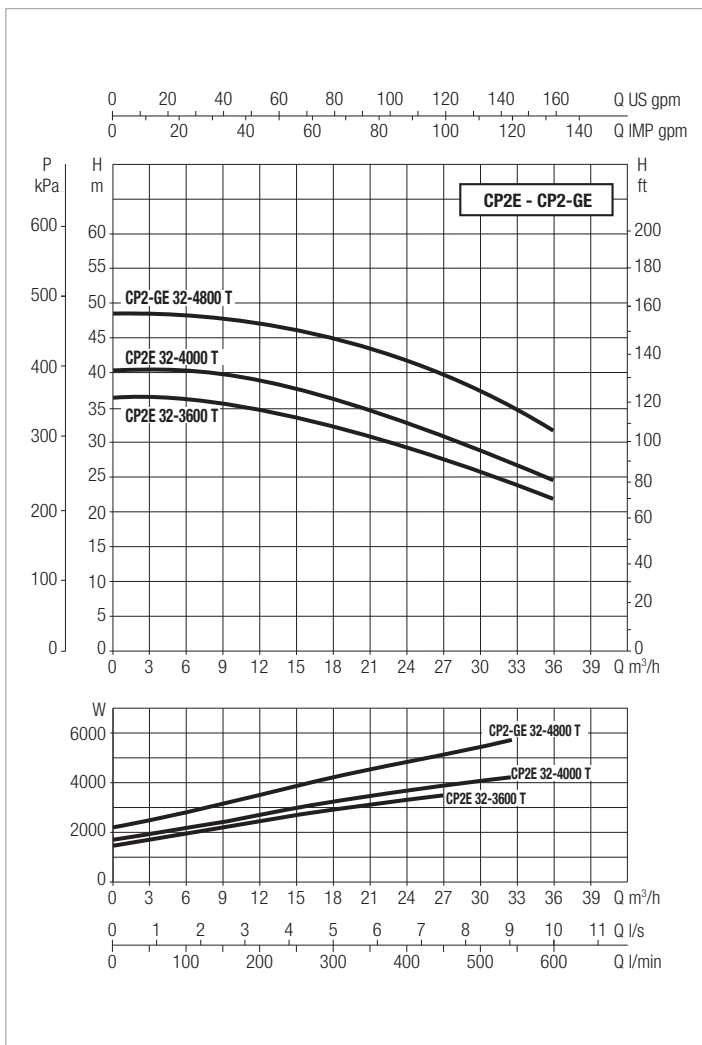
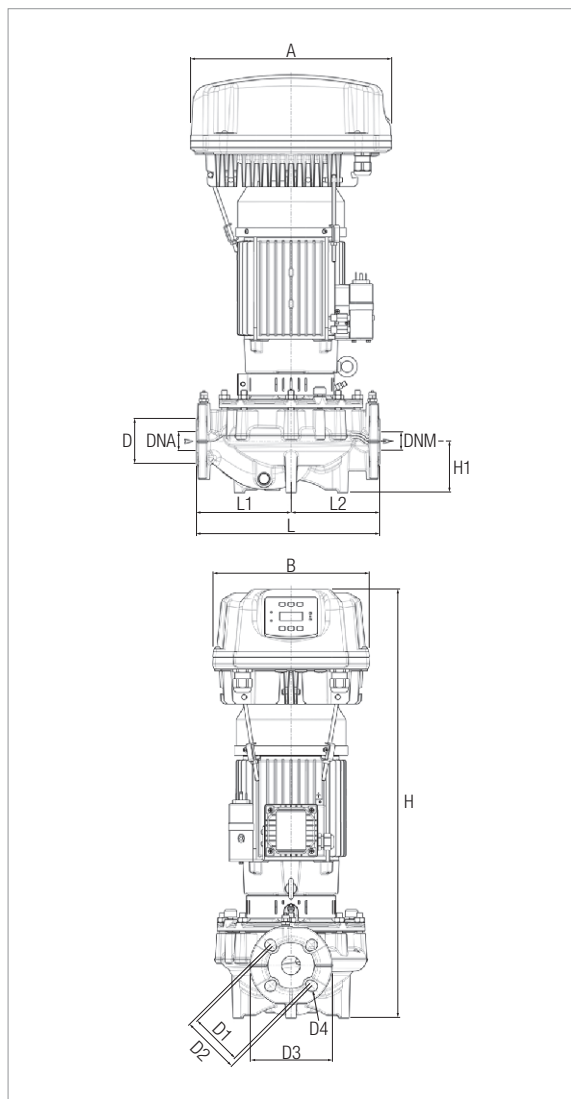

The performance curves are based on kinematic viscosity values = 1 mm²/s and density equal to 1000 kg/m³. Curve tolerance according to ISO 9906.

MODEL	ELECTRICAL DATA							
	CENTRE DISTANCE	PUMP CONNECTIONS	POWER INPUT 50 HZ	P1 MAX [kW]	P2 NOMINAL		In [A]	
					kW	HP	230 V	400 V
CP2E 32-3600 IE3	320	DN 32 PN 16 DN 32 PN 10	400 V	5,6	3	4	-	8,90
CP2E 32-4000 IE3				6,3	4	5,4	-	10,2
CP2-GE 32-4800 IE3				8,3	5,5	7,4	-	12,5

MODEL	A	B	B1	B2	C1	D	D1	S1	D2	S2	D3	H	H1	L	L1	L2	M	DNA	DNM	PACKING DIMENSIONS			VOLUME (mc)	WEIGHT Kg
																				L/A	L/B	H		
CP2E 32-3600 IE3	355	270	130	125	180	80	100	14	90	19	140	730	90	320	165	155	10	32	32	680	430	1084	0,32	52,7
CP2E 32-4000 IE3	355	270	130	125	180	80	100	14	90	19	140	730	90	320	165	155	10	32	32	680	430	1084	0,32	52,7
CP2-GE 32-4800 IE3	355	270	129	120	180	80	100	14	90	19	140	884	90	320	165	155	10	32	32	680	430	1084	0,32	87,8

CP2E - ELECTRONIC IN-LINE PUMPS

Liquid temperature range: from -15°C up to 140°C - Maximum operating pressure: 16 bar (1600 kPa)

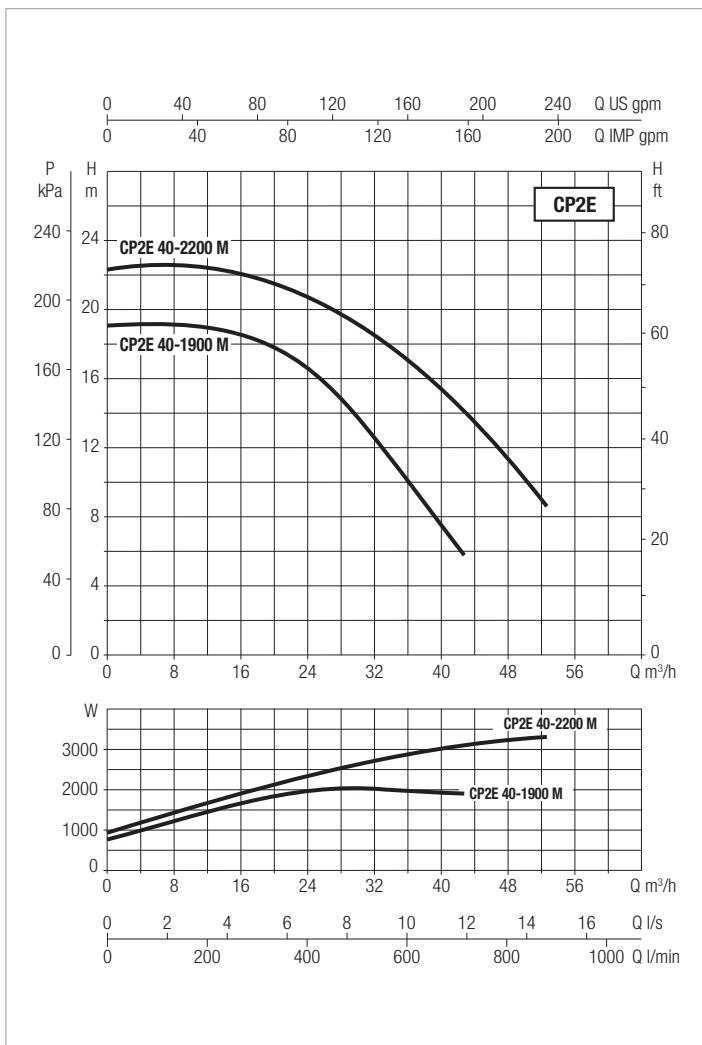
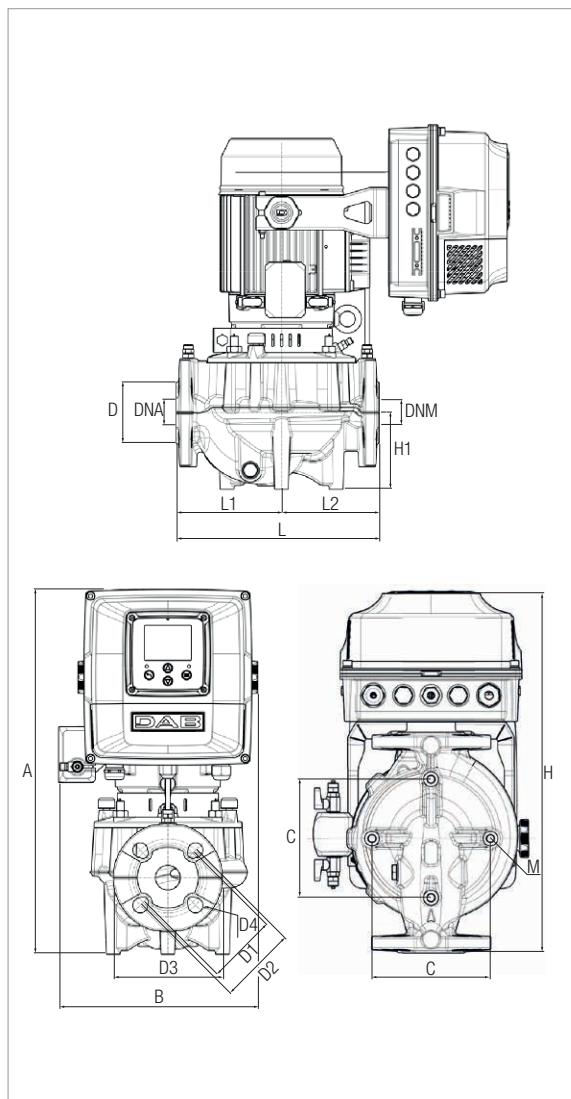

The performance curves are based on kinematic viscosity values = 1 mm²/s and density equal to 1000 kg/m³. Curve tolerance according to ISO 9906.

MODEL	ELECTRICAL DATA							
	CENTRE DISTANCE	PUMP CONNECTIONS	POWER INPUT 50 HZ	P1 MAX [kW]	P2 NOMINAL		In [A]	
					kW	HP	230 V	400 V
CP2E 40-1900 IE5	320	DN 40 PN 16	230 V	2,00	1,5	2	8,90	-
CP2E 40-2200 IE5			400 V	3,30	2,2	3	-	5,30

MODEL	A	B	C	D	D1	D2	D3	D4	H	H1	L	L1	L2	M	DNA	DNM	PACKING DIMENSIONS			VOLUME (mc)	WEIGHT Kg
																	L/A	L/B	H		
CP2E 40-1900 IE5	533	256	180	89	100	110	150	19	463	95	320	168	152	10	40	40	600	300	640	0,12	42,5
CP2E 40-2200 IE5	533	271	180	89	100	110	150	19	463	95	320	168	152	10	40	40	600	300	640	0,12	42,5

CP2E, CP2-GE - ELECTRONIC IN-LINE PUMPS

Liquid temperature range: from -15°C to +140°C - Maximum operating pressure: 16 bar (1600 kPa)

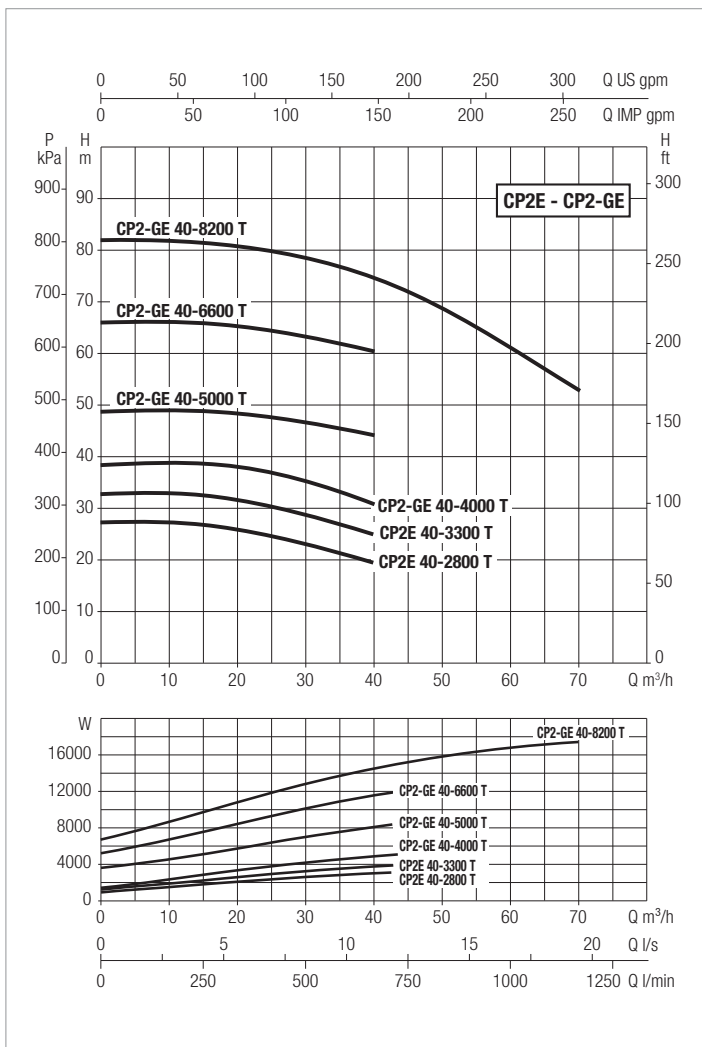
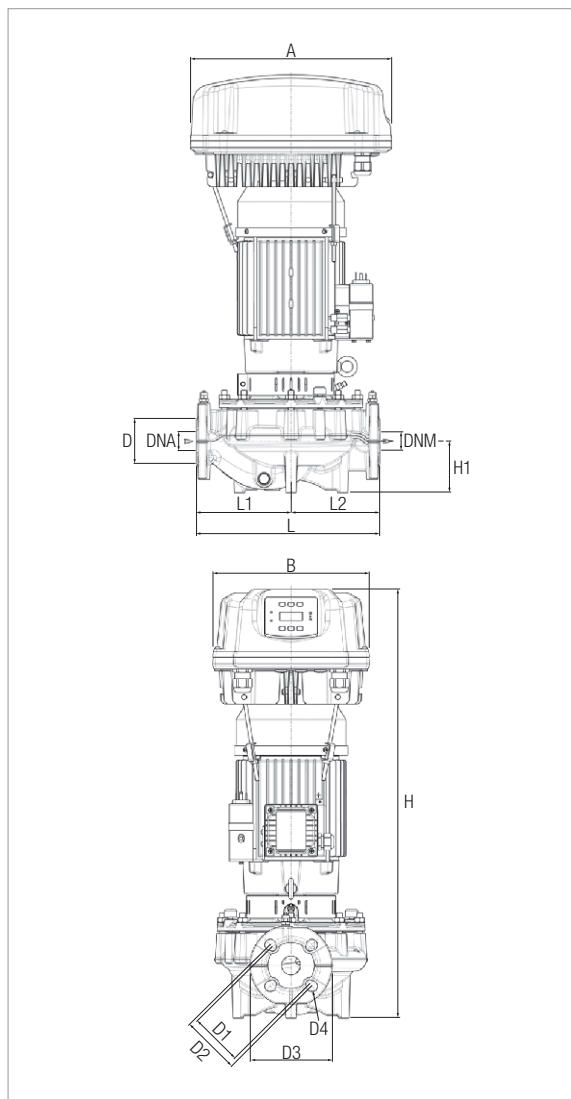

The performance curves are based on kinematic viscosity values = 1 mm²/s and density equal to 1000 kg/m³. Curve tolerance according to ISO 9906.

MODEL	ELECTRICAL DATA							
	CENTRE DISTANCE	PUMP CONNECTIONS	POWER INPUT 50 HZ	P1 MAX [kW]	P2 NOMINAL		In [A]	
					kW	HP	230 V	400 V
CP2E 40-2800 IE3	320	DN 40 PN 16	400	4,4	3	4	-	7,2
CP2E 40-3300 IE3				5,6	4	5,4	-	9,2
CP2-GE 40-4000 IE3				7,1	5,5	7,4	-	10,8
CP2-GE 40-5000 IE3	440			13,2	7,5	10,1	-	19,7
CP2-GE 40-6600 IE3				17,3	11	14,8	-	26,2
CP2-GE 40-8200 IE3				20,5	15	20,1	-	31,8

MODEL	A	B	B1	B2	C1	D	D1	S1	D2	S2	D3	H	H1	L	L1	L2	M	DNA	DNM	PACKING DIMENSIONS			VOLUME (mc)	WEIGHT Kg
	L/A	L/B	H																					
CP2E 40-2800 IE3	355	270	130,6	130,6	180	88	110	20	100	20	150	726	95	320	168	152	10	40	40	680	430	1084	0,32	48,9
CP2E 40-3300 IE3	355	270	130,6	130,6	180	88	110	20	100	20	150	726	95	320	168	152	10	40	40	680	430	1084	0,32	47,9
CP2-GE 40-4000 IE3	355	270	150	150	180	88	110	20	100	20	150	888,5	95	320	168	152	10	40	40	680	430	1084	0,32	82,6
CP2-GE 40-5000 IE3	440	360	180	180	250	88	110	20	100	20	150	965,5	99,5	440	220	220	10	40	40	708	588	1315	0,55	93
CP2-GE 40-6600 IE3	440	360	180	180	250	88	110	20	100	20	150	1088,5	99,5	440	220	220	10	40	40	708	588	1315	0,55	82,6
CP2-GE 40-8200 IE3	440	360	180	180	250	88	110	20	100	20	150	1088,5	99,5	440	220	220	10	40	40	708	588	1315	0,55	82,6

CP2E - ELECTRONIC IN-LINE PUMPS

Liquid temperature range: from -15°C to +140°C - Maximum operating pressure: 16 bar (1600 kPa)

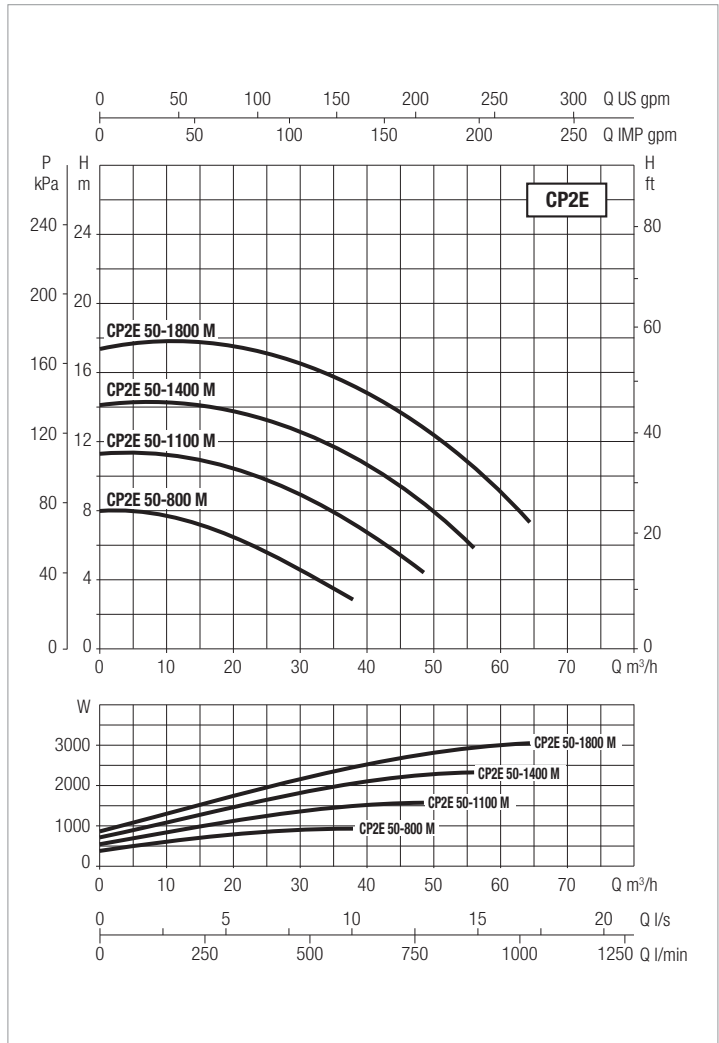
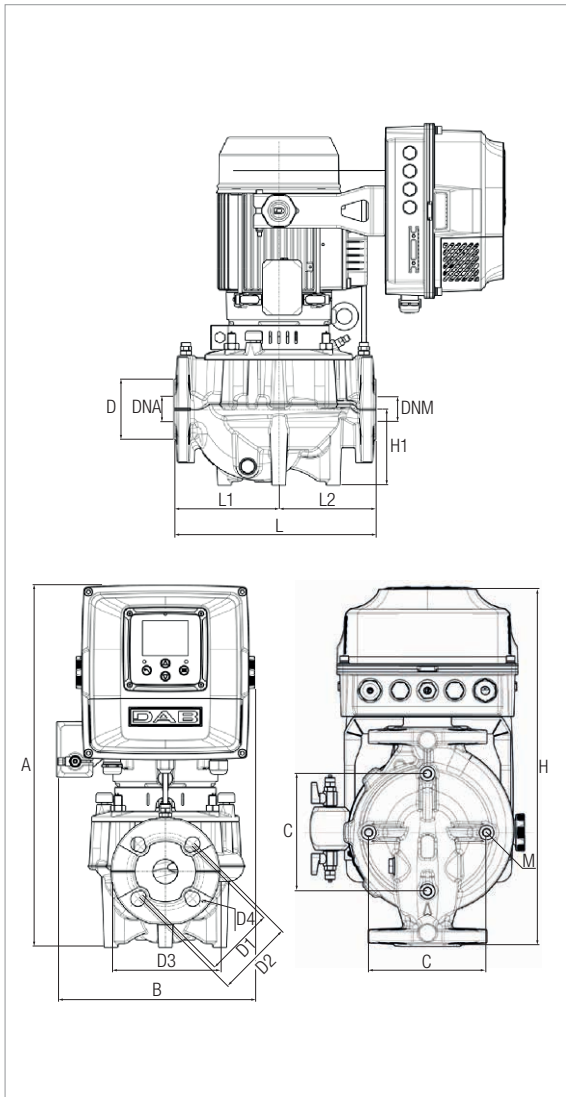

The performance curves are based on kinematic viscosity values = 1 mm²/s and density equal to 1000 kg/m³. Curve tolerance according to ISO 9906.

MODEL	ELECTRICAL DATA							
	CENTRE DISTANCE	PUMP CONNECTIONS	POWER INPUT 50 HZ	P1 MAX [kW]	P2 NOMINAL		In [A]	
					kW	HP	230 V	400 V
CP2E 50-800 IE5	280	DN 50 PN 16	230 V	0,93	0,5	0,7	4,1	-
CP2E 50-1100 IE5				1,5	0,7	0,9	6,9	-
CP2E 50-1400 IE5				2,2	1,5	2	10,1	-
CP2E 50-1800 IE5			400 V	3	2,2	3	-	4,9

MODEL	A	B	C	D	D1	D2	D3	D4	H	H1	L	L1	L2	M	DNA	DNM	PACKING DIMENSIONS			VOLUME (mc)	WEIGHT Kg
																	L/A	L/B	H		
CP2E 50-800 IE5	438	255	100	90	110	125	165	18	431	73	280	140	140	10	50	50	600	300	640	0,12	32
CP2E 50-1100 IE5	508	256	100	90	110	125	165	18	435	73	280	140	140	10	50	50	600	300	640	0,12	32
CP2E 50-1400 IE5	508	256	100	90	110	125	165	18	435	73	280	140	140	10	50	50	600	300	640	0,12	39
CP2E 50-1800 IE5	508	256	100	90	110	125	165	18	435	73	280	140	140	10	50	50	600	300	640	0,12	39

CP2E, CP2-GE - ELECTRONIC IN-LINE PUMPS

Liquid temperature range: from -15°C to +140°C - Maximum operating pressure: 16 bar (1600 kPa)

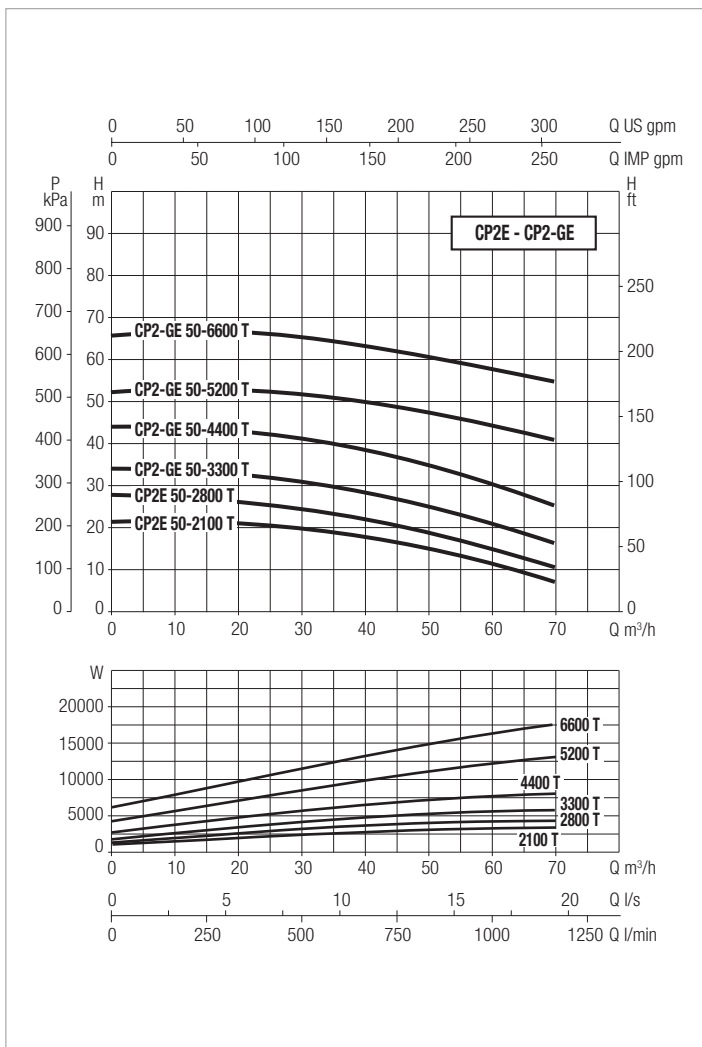
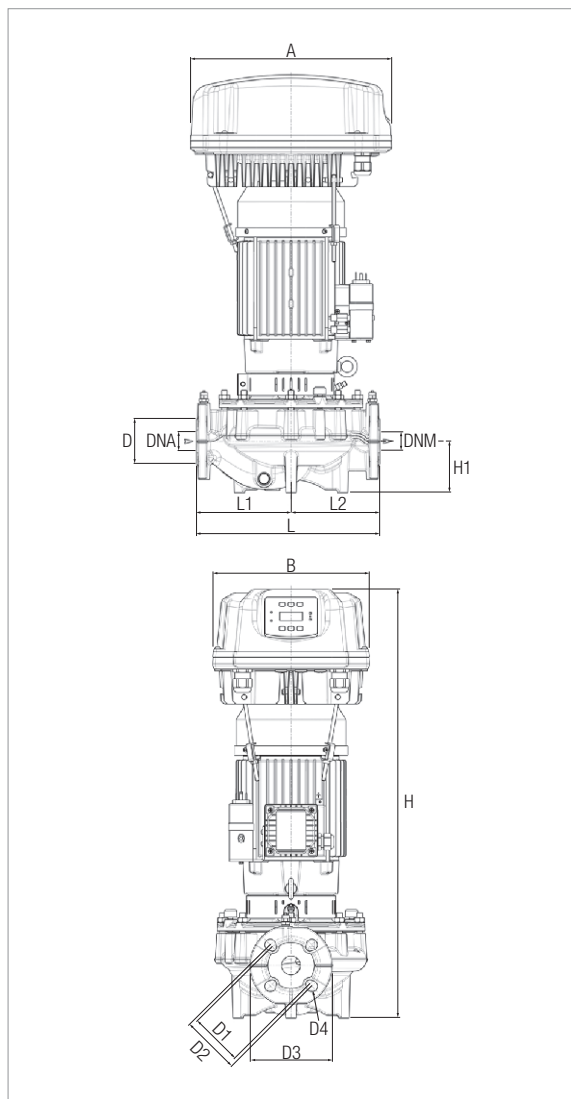

The performance curves are based on kinematic viscosity values = 1 mm²/s and density equal to 1000 kg/m³. Curve tolerance according to ISO 9906.

MODEL	ELECTRICAL DATA							
	CENTRE DISTANCE	PUMP CONNECTIONS	POWER INPUT 50 HZ	P1 MAX [kW]	P2 NOMINAL		In [A]	
					kW	HP	230 V	400 V
CP2E 50-2100 IE3	280	DN 50 PN 16	400 V	4,1	3	4	-	6,7
CP2E 50-2800 IE3	340			5,3	4	5,4	-	8,7
CP2-GE 50-3300 IE3				6,8	5,5	7,4	-	10,3
CP2-GE 50-4400 IE3				9,5	7,5	10,1	-	14,6
CP2-GE 50-5200 IE3				18	11	14,8	-	26,8
CP2-GE 50-6600 IE3	440			20,2	15	20,1	-	31,3

MODEL	A	B	B1	B2	C1	D	D1	S1	D2	S2	D3	DNA	DNM	H	H1	L	L1	L2	M	PACKING DIMENSIONS			VOLUME (mc)	WEIGHT Kg
																				L/A	L/B	H		
CP2E 50-2100 IE3	355	270	112,3	96	100	90	125	23,3	110	18	165	50	50	681,5	73	280	140	140	10	680	430	1084	0,32	49
CP2E 50-2800 IE3	355	270	136,4	131,2	180	100	125	21,8	110	14	165	50	50	755	105	340	172,5	167,5	10	680	430	1084	0,32	49
CP2-GE 50-3300 IE3	355	270	136,4	131,2	180	100	125	21,8	110	14	165	50	50	971,5	105	340	172,5	167,5	10	680	430	1084	0,32	78
CP2-GE 50-4400 IE3	430	340	136,4	131,2	180	100	125	21,8	110	14	165	50	50	971,5	105	340	172,5	167,5	10	708	588	1315	0,55	80
CP2-GE 50-5200 IE3	440	369	189	180	180	100	125	21,8	110	14	165	50	50	1116	128,4	440	220	220	10	708	588	1315	0,55	152
CP2-GE 50-6600 IE3	440	369	189	180	180	100	125	21,8	110	14	165	50	50	1116	128,4	440	220	220	10	708	588	1315	0,55	152

DCP2E - ELECTRONIC IN-LINE PUMPS

Liquid temperature range: from -15°C up to 140°C - Maximum operating pressure: 16 bar (1600 kPa)

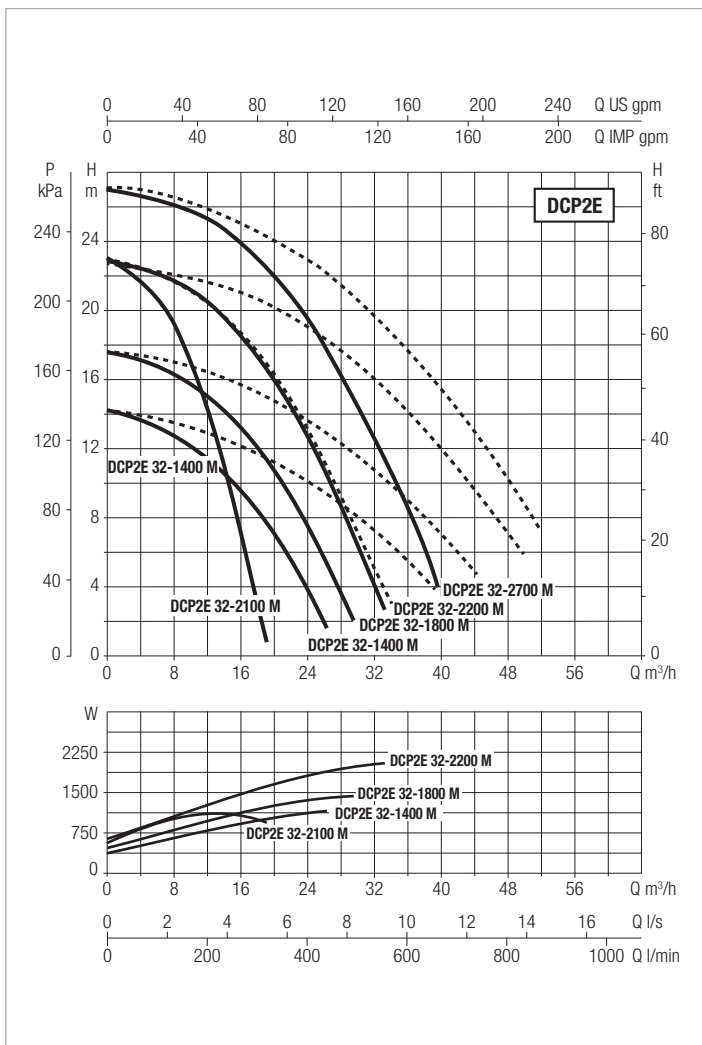
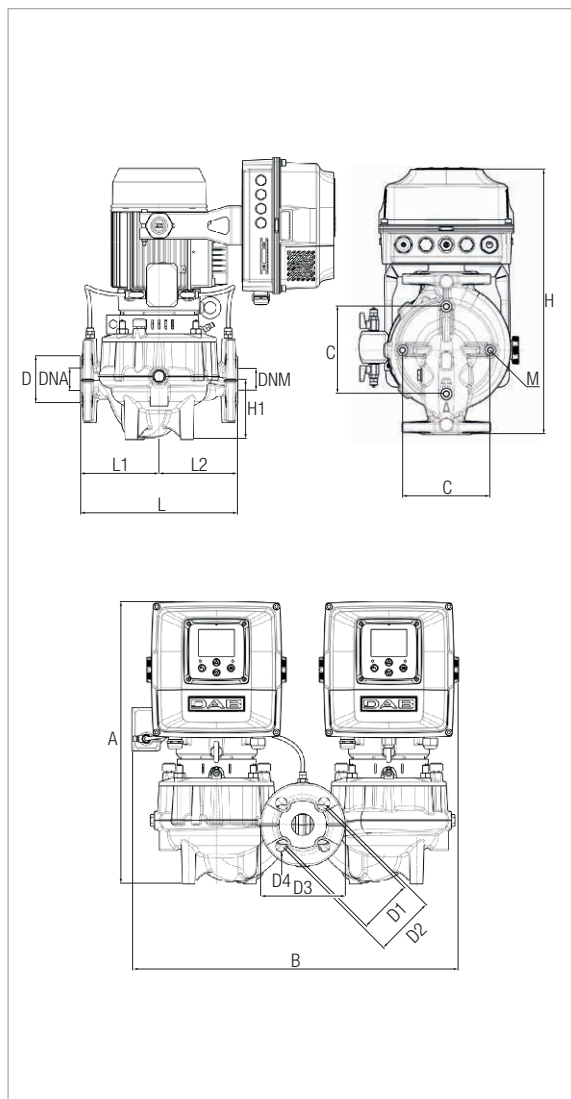

The performance curves are based on kinematic viscosity values = 1 mm²/s and density equal to 1000 kg/m³. Curve tolerance according to ISO 9906.

MODEL	ELECTRICAL DATA							
	CENTRE DISTANCE	PUMP CONNECTIONS	POWER INPUT 50 HZ	P1 MAX [kW]	P2 NOMINAL		In [A]	
					kW	HP	230 V	400 V
DCP2E 32-1400 IE5	260	DN 32 PN 16 DN 32 PN 10	230 V	0,93	0,7	0,9	5,1	-
DCP2E 32-1800 IE5				1,5	1,1	1,5	6,64	-
DCP2E 32-2100 IE5				1,13	0,7	0,9	5	-
DCP2E 32-2200 IE5				2	1,5	2	8,8	-
DCP2E 32-2700 IE5	320		400 V	3,4	2,2	2,3	-	5,3

MODEL	A	B	C1	C2	D	D1	D2	D3	D4	H	H1	L	L1	L2	M	DNA	DNM	PACKING DIMENSIONS			VOLUME (mc)	WEIGHT Kg
																		L/A	L/B	H		
DCP2E 32-1400 IE5	467	540	140	388	78	90	100	141	19	426	98	260	135	125	10	32	32	720	600	640	0,28	55
DCP2E 32-1800 IE5	467	540	140	388	78	90	100	141	19	426	98	260	135	125	10	32	32	720	600	640	0,28	55
DCP2E 32-2100 IE5	537	540	140	388	78	90	100	140	19	430	98	260	135	125	10	32	32	720	600	640	0,28	55
DCP2E 32-2200 IE5	537	540	140	388	78	90	100	140	19	430	98	260	135	125	10	32	32	720	600	640	0,28	77,5
DCP2E 32-2700 IE5	537	620	180	477	79	90	100	140	19	460	90	320	165	155	10	32	32	720	600	640	0,28	77,5



DCP2E, DCP2-GE - ELECTRONIC IN-LINE PUMPS

Liquid temperature range: from -15°C to +140°C - Maximum operating pressure: 16 bar (1600 kPa)

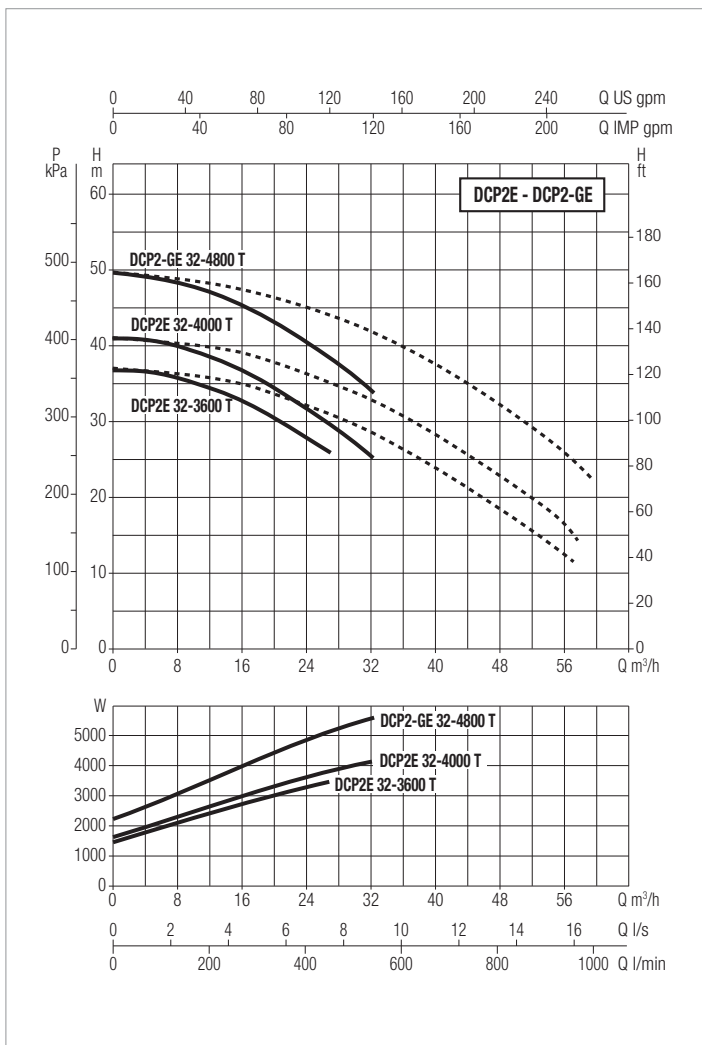
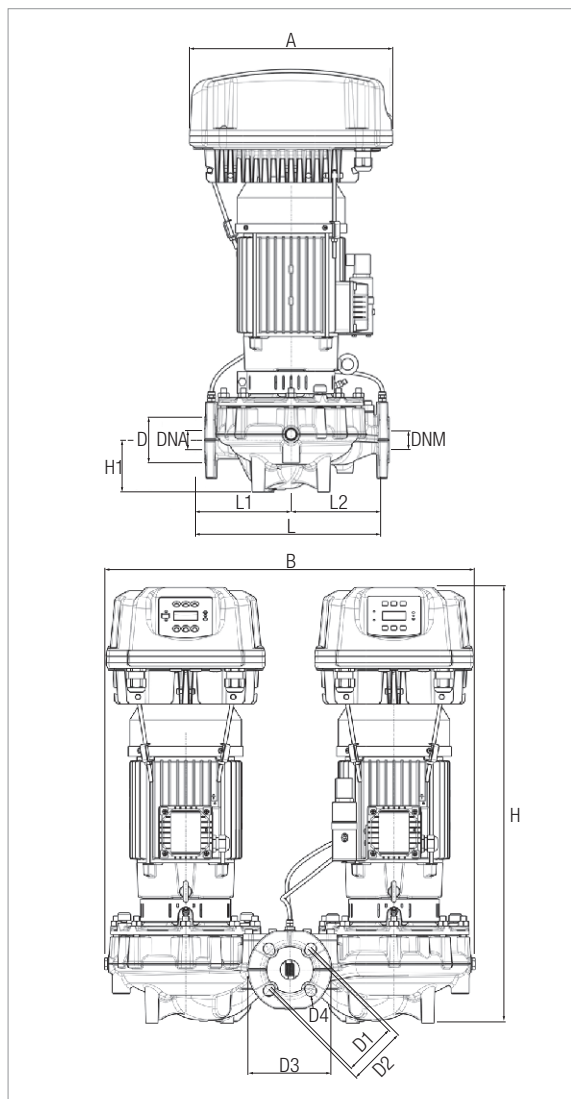

The performance curves are based on kinematic viscosity values = 1 mm²/s and density equal to 1000 kg/m³. Curve tolerance according to ISO 9906.

MODEL	ELECTRICAL DATA							
	CENTRE DISTANCE	PUMP CONNECTIONS	POWER INPUT 50 HZ	P1 MAX [kW]	P2 NOMINAL		In [A]	
					kW	HP	230 V	400 V
DCP2E 32-3600 IE3	320	DN 32 PN 16 DN 32 PN 10	400 V	5,6	3	4	-	8,9
DCP2E 32-4000 IE3				6,3	4	5,4	-	10,2
DCP2-GE 32-4800 IE3				8,3	5,5	7,4	-	12,5

MODEL	A	B	D	D1	D2	D3	D4	DNA	DNM	H	H1	L	L1	L2	PACKING DIMENSIONS			VOLUME (mc)	WEIGHT Kg
															L/A	L/B	H		
DCP2E 32-3600 IE3	355	622	78	100	90	140	-	32	32	730	90	320	150	170	680	430	1084	0,32	52,7
DCP2E 32-4000 IE3	355	622	78	100	90	140	-	32	32	730	90	320	150	170	680	430	1084	0,32	52,7
DCP2-GE 32-4800 IE3	355	622	78	100	90	140	-	32	32	884	90	320	150	170	680	430	1084	0,32	87,8

DCP2E - ELECTRONIC IN-LINE PUMPS

Liquid temperature range: from -15°C up to 140°C - Maximum operating pressure: 16 bar (1600 kPa)

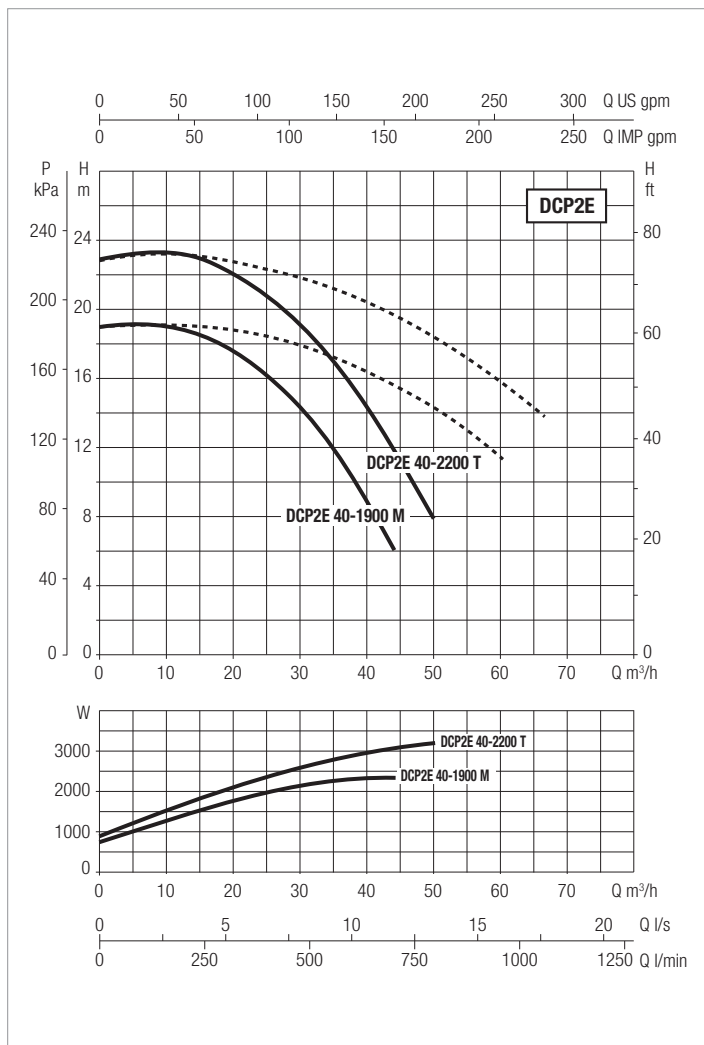
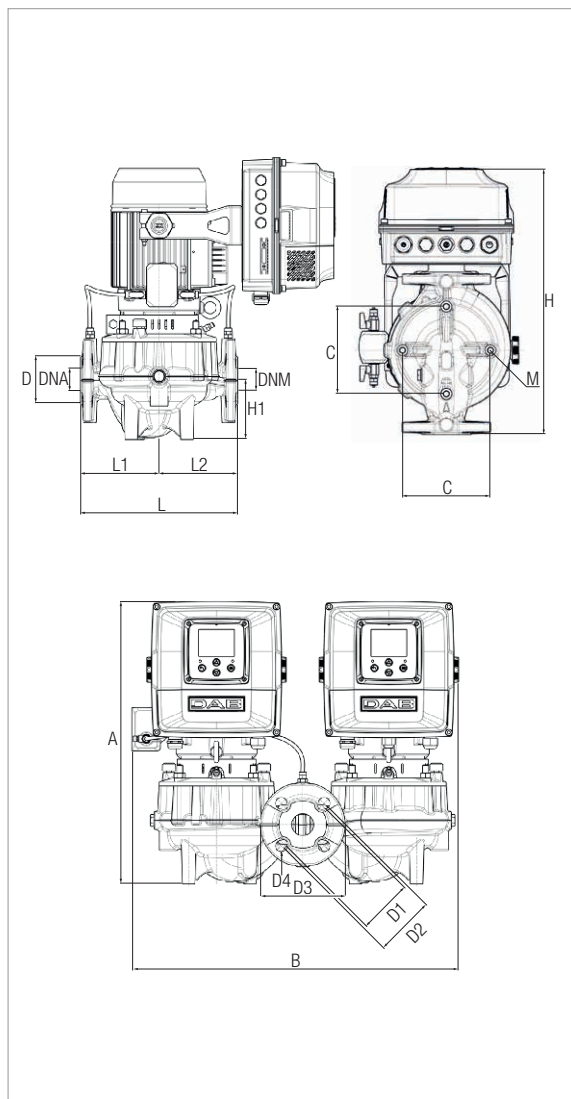

The performance curves are based on kinematic viscosity values = 1 mm²/s and density equal to 1000 kg/m³. Curve tolerance according to ISO 9906.

MODEL	ELECTRICAL DATA							
	CENTRE DISTANCE	PUMP CONNECTIONS	POWER INPUT 50 HZ	P1 MAX [kW]	P2 NOMINAL		In [A]	
					kW	HP	230 V	400 V
DCP2E 40-1900 IE5	320	DN 40 PN 16	230 V	2,00	1,5	2	8,9	-
DCP2E 40-2200 IE5			400 V	3,30	2,2	3	-	5,3

MODEL	A	B	C1	C2	D	D1	D2	D3	D4	H	H1	L	L1	L2	M	DNA	DNM	PACKING DIMENSIONS			VOLUME (mc)	WEIGHT Kg
																		L/A	L/B	H		
																		DCP2E 40-1900 IE5	533	620		
DCP2E 40-2200 IE5	533	620	180	478	89	100	110	150	19	463	95	320	168	152	10	40	40	720	600	640	0,28	80,5

DCP2E, DCP2-GE - ELECTRONIC IN-LINE PUMPS

Liquid temperature range: from -15°C to +140°C - Maximum operating pressure: 16 bar (1600 kPa)

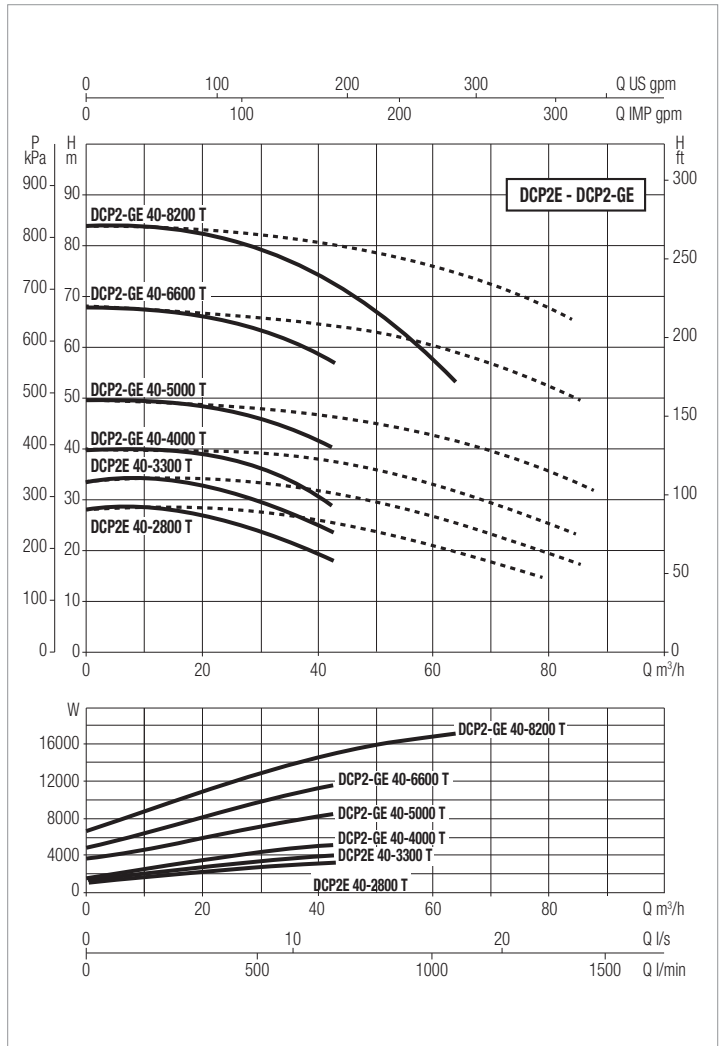
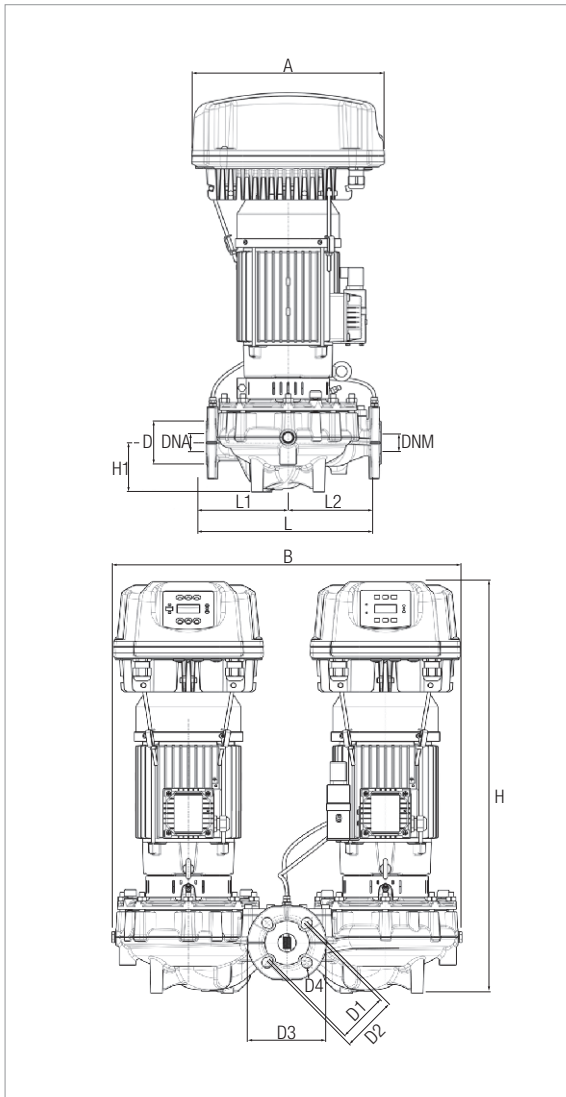

The performance curves are based on kinematic viscosity values = 1 mm²/s and density equal to 1000 kg/m³. Curve tolerance according to ISO 9906.

MODEL	ELECTRICAL DATA							
	CENTRE DISTANCE	PUMP CONNECTIONS	POWER INPUT 50 HZ	P1 MAX [kW]	P2 NOMINAL		In [A]	
					kW	HP	230 V	400 V
DCP2E 40-2800 IE3	320	DN 40 PN 16	400 V	4,4	3	4	-	7,2
DCP2E 40-3300 IE3				5,6	4	5,4	-	9,2
DCP2-GE 40-4000 IE3				7,1	5,5	7,4	-	10,8
DCP2-GE 40-5000 IE3				13,2	7,5	10,1	-	19,7
DCP2-GE 40-6600 IE3				17,3	11	14,8	-	26,2
DCP2-GE 40-8200 IE3				20,5	15	20,1	-	31,8

MODEL	A	B	D	D1	D2	D3	D4	DNA	DNM	H	H1	L	L1	L2	PACKING DIMENSIONS			VOLUME (mc)	WEIGHT Kg
															L/A	L/B	H		
DCP2E 40-2800 IE3	355	622	88	110	100	150	-	40	40	726	95	320	170	150	680	430	1084	0,32	100,7
DCP2E 40-3300 IE3	355	622	88	110	100	150	-	40	40	726	95	320	170	150	680	430	1084	0,32	100,7
DCP2-GE 40-4000 IE3	355	622	88	110	100	150	-	40	40	888,5	95	320	170	150	970	848	1234	1,02	217,2
DCP2-GE 40-5000 IE3	430	770	88	110	100	150	-	40	40	965,5	99,5	440	240	200	970	848	1234	1,02	217,2
DCP2-GE 40-6600 IE3	430	770	88	110	100	150	-	40	40	1088,5	99,5	440	240	200	970	848	1234	1,02	303,2
DCP2-GE 40-8200 IE3	430	770	88	110	100	150	-	40	40	1088,5	99,5	440	240	200	970	848	1234	1,02	303,2

DCP2E - ELECTRONIC IN-LINE PUMPS

Liquid temperature range: from -15°C to +140°C - Maximum operating pressure: 16 bar (1600 kPa)

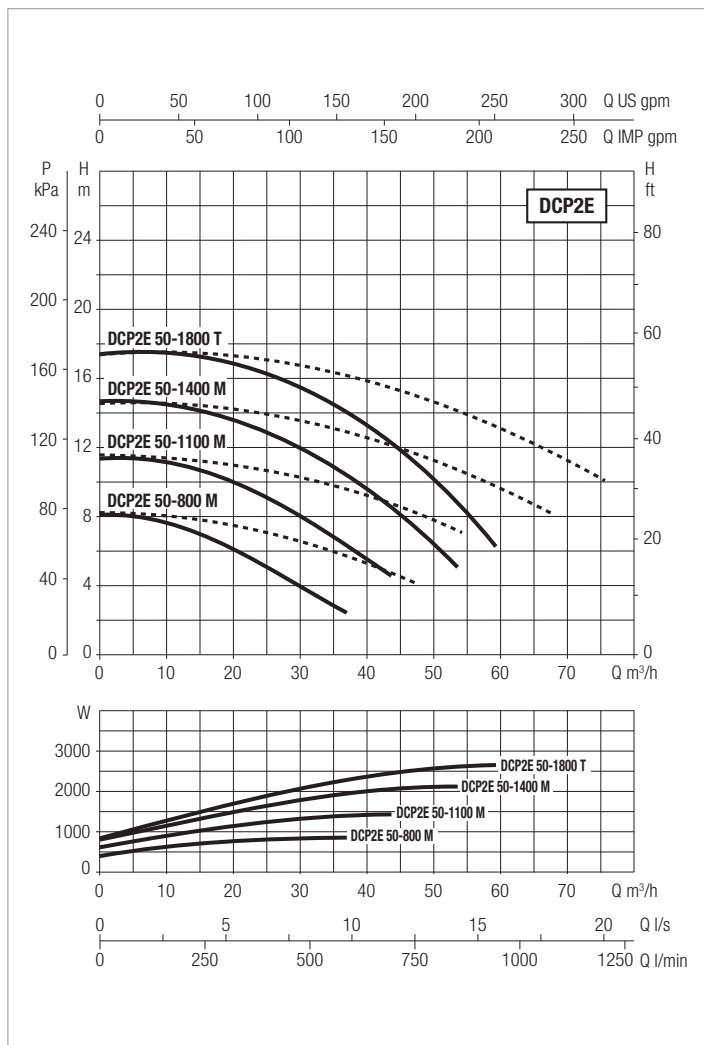
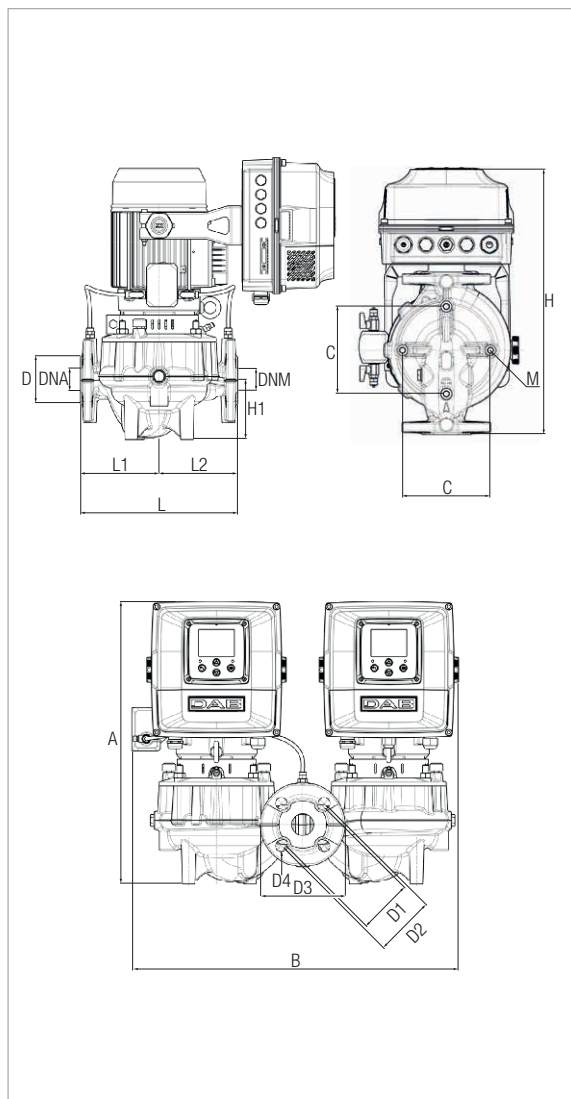

The performance curves are based on kinematic viscosity values = 1 mm²/s and density equal to 1000 kg/m³. Curve tolerance according to ISO 9906.

MODEL	ELECTRICAL DATA							
	CENTRE DISTANCE	PUMP CONNECTIONS	POWER INPUT 50 HZ	P1 MAX [kW]	P2 NOMINAL		In [A]	
					kW	HP	230 V	400 V
DCP2E 50-800 IE5	280	DN 50 PN 16	230 V	0,93	0,5	0,7	4,1	-
DCP2E 50-1100 IE5				1,5	0,7	0,9	6,9	-
DCP2E 50-1400 IE5				2,2	1,5	2	10,1	-
DCP2E 50-1800 IE5			400 V	3	2,2	3	-	4,9

MODEL	A	B	C1	C2	D	D1	D2	D3	D4	H	H1	L	L1	L2	M	DNA	DNM	PACKING DIMENSIONS			VOLUME (mc)	WEIGHT Kg
																		L/A	L/B	H		
DCP2E 50-800 IE5	438	555	100	392	90	110	125	165	18	431	73	280	140	140	10	50	50	720	600	640	0,28	54
DCP2E 50-1100 IE5	508	555	100	392	90	110	125	165	18	435	73	280	140	140	10	50	50	720	600	640	0,28	54
DCP2E 50-1400 IE5	508	555	100	392	90	110	125	165	18	435	73	280	140	140	10	50	50	720	600	640	0,28	68
DCP2E 50-1800 IE5	508	555	100	392	90	110	125	165	18	435	73	280	140	140	10	50	50	720	600	640	0,28	68

DCP2E, DCP2-GE - ELECTRONIC IN-LINE PUMPS

Liquid temperature range: from -15°C to +140°C - Maximum operating pressure: 16 bar (1600 kPa)

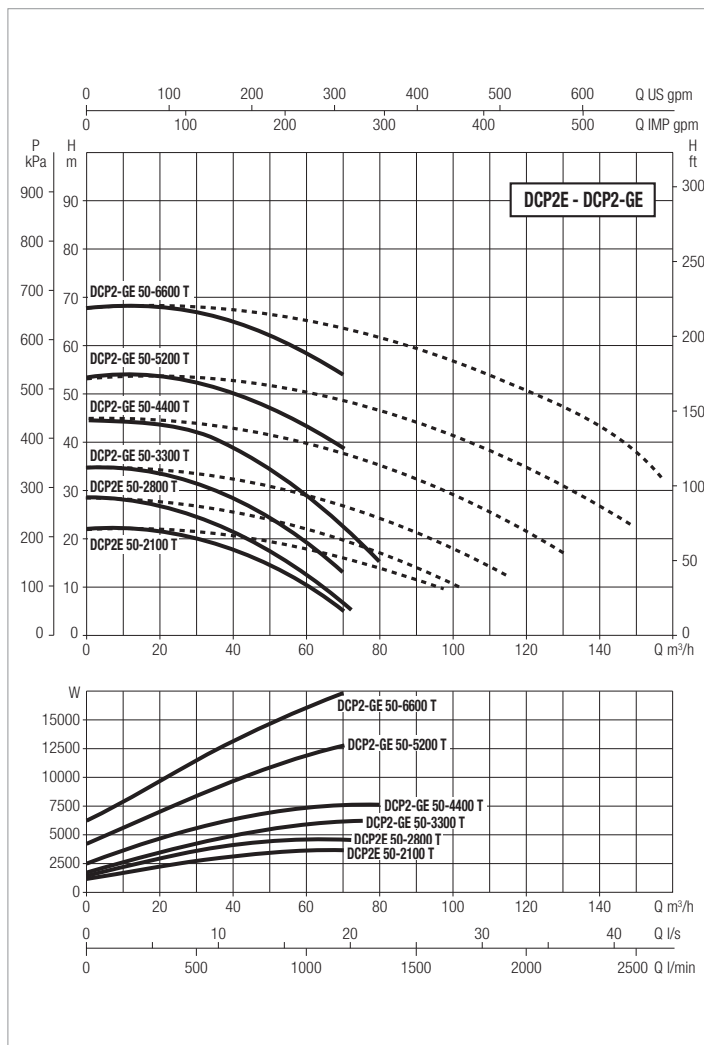
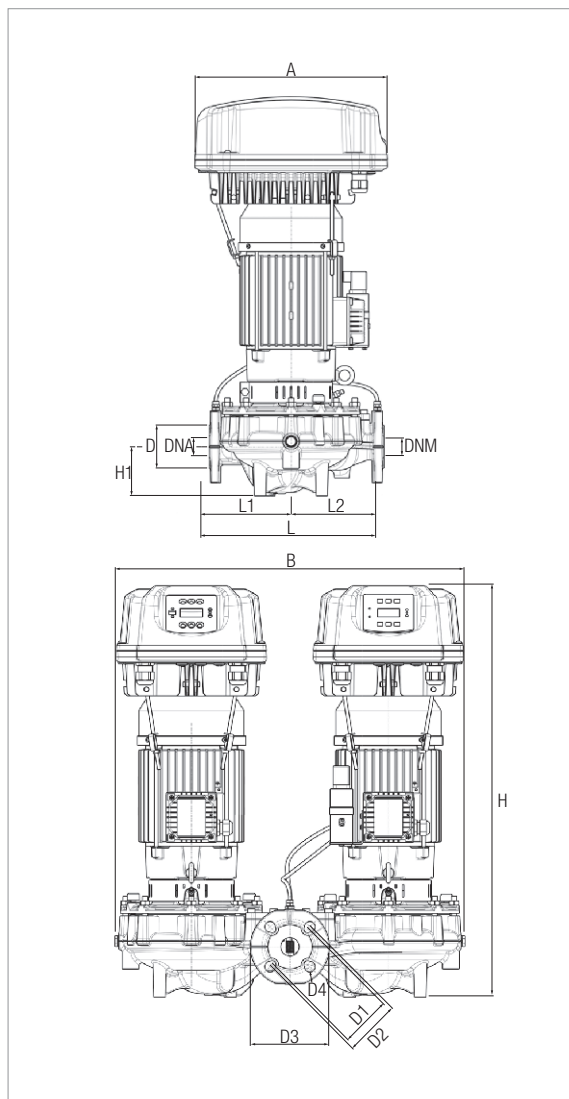

The performance curves are based on kinematic viscosity values = 1 mm²/s and density equal to 1000 kg/m³. Curve tolerance according to ISO 9906.

MODEL	ELECTRICAL DATA							
	CENTRE DISTANCE	PUMP CONNECTIONS	POWER INPUT 50 HZ	P1 MAX [kW]	P2 NOMINAL		In [A]	
					kW	HP	230 V	400 V
DCP2E 50-2100 IE3	280	DN 50 PN 16	400 V	4,1	3	4	-	6,7
DCP2E 50-2800 IE3	340			5,3	4	5,4	-	8,7
DCP2-GE 50-3300 IE3				6,8	5,5	7,4	-	10,3
DCP2-GE 50-4400 IE3				9,5	7,5	10,1	-	14,6
DCP2-GE 50-5200 IE3				18	11	14,8	-	26,8
DCP2-GE 50-6600 IE3	440			20,2	15	20,1	-	31,3

MODELLO	A	B	D	D1	D2	D3	D4	DNA	DNM	H	H1	L	L1	L2	PACKING DIMENSIONS			VOLUME (mc)	WEIGHT Kg
															L/A	L/B	H		
DCP2E 50-2100 IE3	355	570	90	125	110	165	-	50	50	682	73	280	133	147	680	430	1084	0,32	49
DCP2E 50-2800 IE3	355	730	100	125	110	165	-	50	50	755	105	340	190	150	680	430	1084	0,32	49
DCP2-GE 50-3300 IE3	355	730	100	125	110	165	-	50	50	971,5	105	340	190	150	680	430	1084	0,32	78
DCP2-GE 50-4400 IE3	430	860	100	125	110	165	-	50	50	971,5	105	340	190	150	708	588	1315	0,55	80
DCP2-GE 50-5200 IE3	440	869	100	125	110	165	-	50	50	1116	128,4	440	230	210	708	588	1315	0,55	152
DCP2-GE 50-6600 IE3	440	869	100	125	110	165	-	50	50	1116	128,4	440	230	210	708	588	1315	0,55	152

H₂D DIGITAL SERVICE

THE SMART PLATFORM FOR MANAGING DAB DEVICES REMOTELY

H₂D IS THE DAB PLATFORM - AVAILABLE ON MOBILE AND DESKTOP - THAT PAIRS WITH LATEST-GENERATION DAB DEVICES TO SHOW YOU WHAT'S GOING ON INSIDE YOUR SYSTEMS.

It allows you to configure your pump and optimise its operation remotely, saving time, resources and money.

Ideal for anyone seeking to future-proof their business with solutions designed to improve processes, offer more service, and be environmentally responsible.

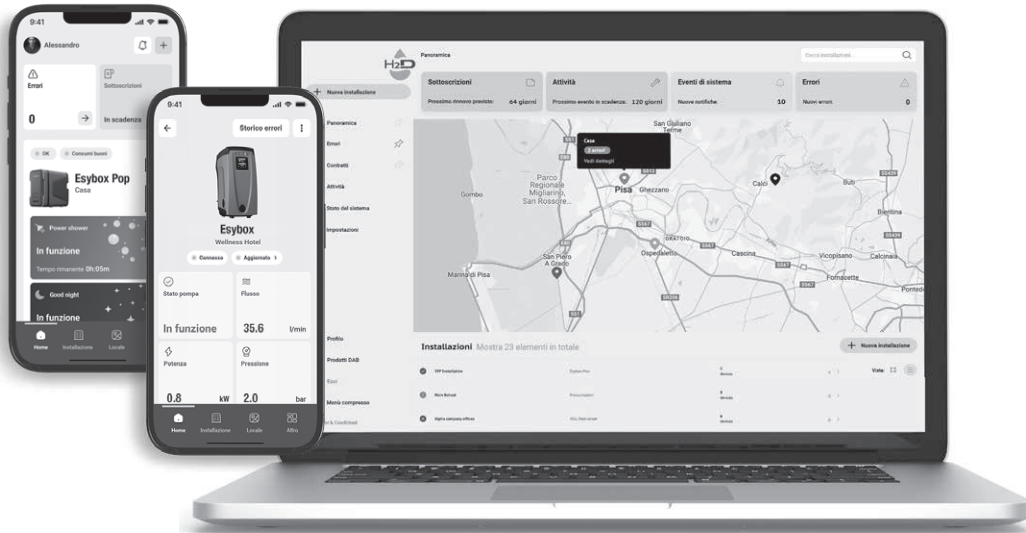

H₂D FOR PROFESSIONALS

H₂D simplifies and streamlines work routines, allowing for precise configuration of all parameters.

SEE THE FUTURE OF YOUR BUSINESS THROUGH A NEW LENS

Desktop and mobile solutions work together seamlessly. With user-friendly access on your smartphone, it's never been easier to communicate with pumps on site or keep an eye on your systems from anywhere. From your desktop, you can dive deeper into data analysis. You can easily enhance workflow, improve customer service, and grow your business.



OPTIMISE TIME AND WORK

H₂D allows systems to be controlled remotely and, where needed, work on site is easier to plan.



PROBLEM FIXED FIRST TIME, EVERY TIME

H₂D provides all the info you need to prepare the job beforehand for a quick and permanent fix, so the technician can get everything done in one go.



LITTLE OR NO DISRUPTION

Remote monitoring allows you to address potential issues and prevent disruptions.



MORE SERVICE AND LESS URGENT CALLOUTS = INCREASED PROFIT

With remote monitoring, we offer a 24/7 service that includes preventive maintenance services, helping to avoid emergencies.



SATISFIED CUSTOMERS

With parameters optimised remotely, the system ensures consistently smooth operation.



FROM DCONNECT TO H₂D

H₂D replaces and improves on DConnect. Latest generation DAB products connect effortlessly to H₂D.

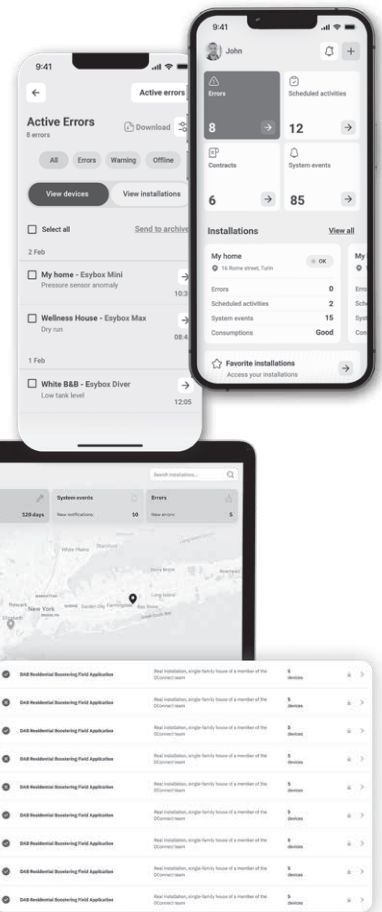

H₂D DIGITAL SERVICE

THE SMART PLATFORM FOR MANAGING DAB DEVICES REMOTELY



H₂D FOR HOMEOWNERS AND END USERS

H₂D is a tool designed to help you manage water use effectively, optimising consumption, costs, and comfort.



OVERVIEW

With H₂D monitoring your water usage and device status in real-time is easy and convenient. If any issues arise, you can contact support immediately, regardless of your location.



SMART HOME. TALK TO YOUR ESYBOX!

You can activate comfort modes by speaking to voice assistants like Alexa and Google Home. For example, you can say, "Alexa, activate Power Shower."

COMFORT FUNCTIONS

You can access these functions through an app, allowing you to customise the system's performance and features to balance comfort and energy consumption.

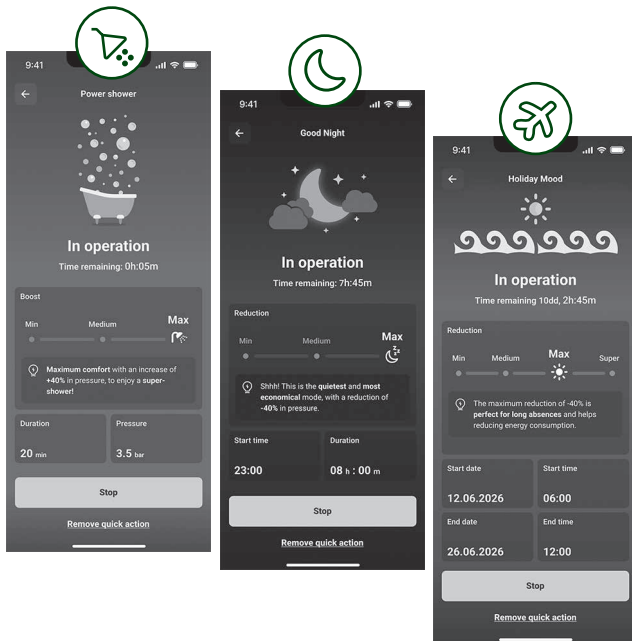

POWER SHOWER

Turn a regular shower into a "power shower": this feature increases water pressure just for the time it takes to shower, while reducing usage for the rest of the day.



GOOD NIGHT

During the night or for a quick nap, you can activate sleep mode, which switches the already quiet pump to a whisper-quiet operation, further reducing energy usage.



HOLIDAY MOOD (Only for Esybox Pop)

This important feature helps minimise device activity, thereby saving energy during vacations or extended periods when you are away.

INSTALL H₂D NOW!



LEARN MORE
H2D.COM/EN



HOW TO USE H₂D

