

S4

4" SUBMERSIBLE ELECTRIC PUMPS

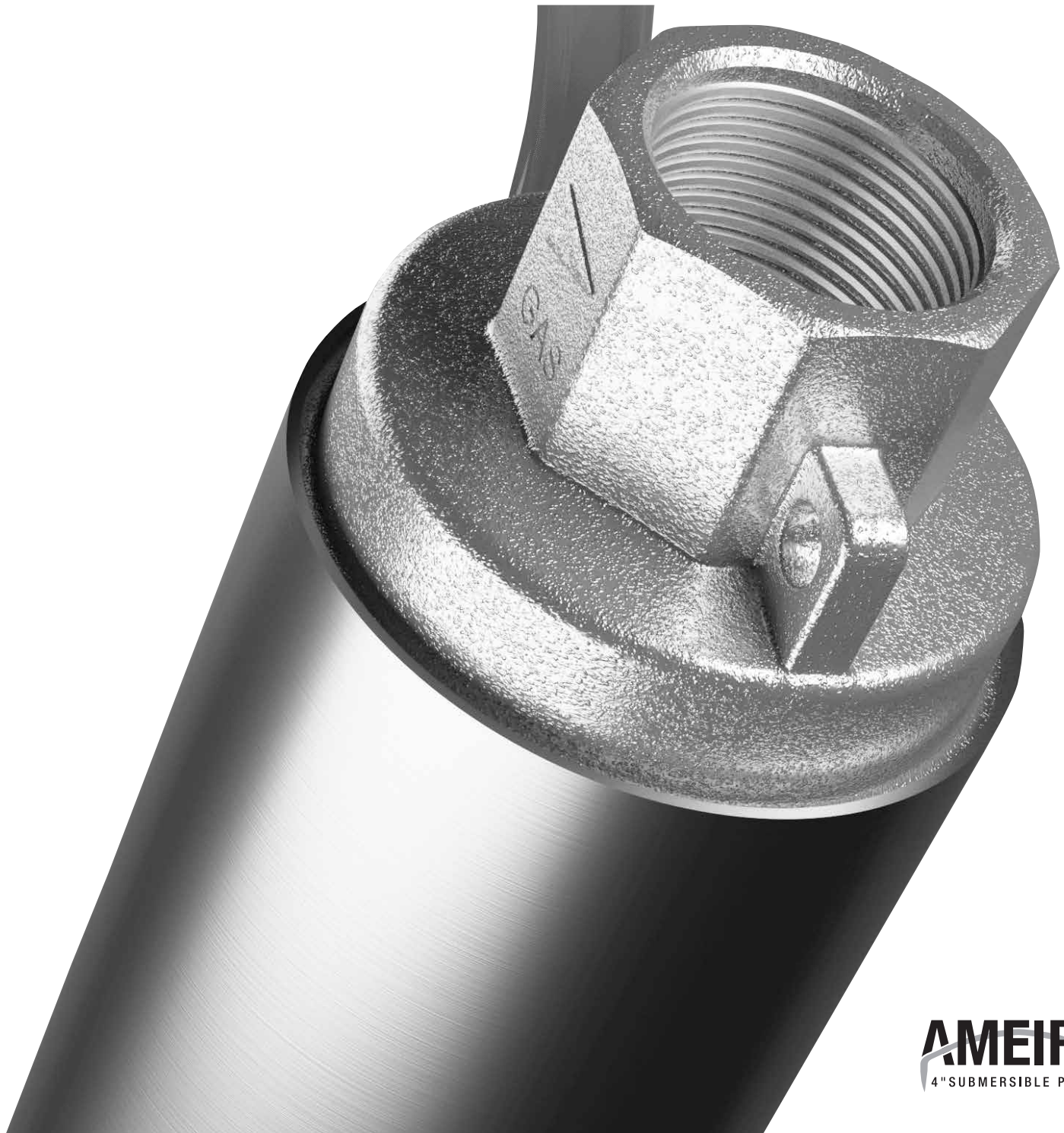



TECHNICAL DATA

Flow rate: up to 21.6 m³/h
Maximum head: 427 m
Maximum immersion depth: 4GG: 300 m - 40L: 250 m
Type of pumped liquid : clean, free of solids or abrasive substances, non-viscous, non-aggressive, non-crystallised and chemically neutral.
Maximum quantity of sand: 150 g/m³
Liquid temperature range: 0 °C to +40 °C
Delivery port diameter: S4-1, S4-2, S4-3, S4-4, S4-6: 1" 1/4
 S4-8, S4-12, S4-16: 2"
Maximum pump diameter: 99 mm
Impeller construction material: technopolymer
Maximum number of starts: 20/h
Motor protection degree: IP 68
Motor insulation class: F
Single phase power input: 1x230 V 50 Hz
Three phase power input: 3x230 V 50 Hz - 3x400 V 50 Hz
Available versions:
 - Only pump body
 - Pump body with oil-filled motor
 - Pump body with water-filled motor
 - Kit with pump body and motor, power supply cable, cord and control box for single-phase version.
Power cable and cord of 15 meters: S4 1/13, S4 2/7 S4 2/10, S4 3/6, S4 3/9, S4 4/4, S4 4/7, S4 4/9, S4 6/5, S4 6/7, S4 8/5, S4 6/10, S4 8/7, S4 8/9, S4 12/6, S4 12/9, S4 12/13, S4 16/8, S4 16/12
Power cable and cord of 30 meters: S4 1/19, S4 1/26, S4 2/14, S4 3/13, S4 4/14, S4 6/14, S4 6/21, S4 8/15
Power cable and cord of 40 meters: S4 1/37, S4 1/48, S4 2/20, S4 2/28, S4 2/40, S4 3/19, S4 3/25, S4 3/32, S4 3/39, S4 4/19, S4 4/27
Possible type of installation: Fixed in vertical position. Horizontal installation is possible, it is recommended to install a cooling sleeve
Special versions on request: Different voltages, different cable lengths, version with 4GX or 4TW motor
Certification: ACS (hydraulic part only), WRAS, DM 174

4" multi-impeller borehole pumps for clean water, designed for water boosting, gardening and irrigation, lifting water from boreholes in residential building service, commercial building service and irrigation systems also for agriculture. The S4 pumps must be installed in wells with a diameter of at least 4", or in tanks or cisterns and it increases the pressure of water that can then be used for example to water medium or large gardens or (in the case of models with a greater flow and head) in irrigation systems in agriculture.

Available as standard:

- Only pump body
- Pump body with oil-filled motor
- Pump body with water-filled motor
- Kit with pump body and motor, power supply cable, cord and control box for single-phase version.

CONSTRUCTION FEATURES OF THE PUMP

Technopolymer impellers housed in the stage box with stainless steel adjustment rings. Pump liner, shaft, coupling with motor, integrated suction filter and stainless steel cable cover. Suction and delivery supports in micro-cast AISI 304 stainless steel. Removable built-in non-return valve in technopolymer or with stainless steel plate (depending on model). Impellers designed to ensure high levels of efficiency in accordance with Directive 2009/125/EC (Eco design - ErP) with MEI index ≥ 0.4 for the whole range. ACS (hydraulic part only), WRAS and DM 174 certificated.

CONSTRUCTION FEATURES OF THE MOTOR

Pump body can be coupled to 4GG and 40L motors (4TW or 4GX on request).

4GG is a two-pole asynchronous motor with the parts in contact with water made of AISI 304 stainless steel. The thrust block and bushes are cooled and lubricated with a mixture of water and glycol. Rotor mounted on a Kingsbury type self-centring thrust block capable of withstanding high axial loads. The stator is immersed in **thermosetting insulating resin with high heat dissipation capacity** and encapsulated in an airtight AISI 304 stainless steel casing.

40L is a two-pole asynchronous motor with the parts in contact with water made of AISI 304L stainless steel. Cooling and lubrication of ball bearings is ensured by a special liquid approved for contact with food. The rewindable stator is housed in an AISI 304L stainless steel casing fixed with steel pins to the upper support of the motor. Equipped with a carbon-ceramic mechanical seal.

Both motors have removable cable connector, ACS, WRAS and KTW certified cable, motor suitable for use with inverters (30 Hz - 50 Hz). In the 50 Hz single-phase version, the capacitor and manually resettable overload protection are in the electrical control panel supplied as standard or to be ordered separately depending on the configuration selected. In the three-phase version, the protection must be guaranteed by the user.

MATERIALS

N°	PART*	MATERIALS	
1	LOWER SUPPORT	PRECISION CAST STEEL AISI 304	
2	SCREWS	STAINLESS STEEL AISI 304	
3	STAGE HOUSING	S4 1/13÷37 S4 2÷8/... UP TO 20 STAGES	TECHNOPOLYMER + STAINLESS STEEL WEAR RING
		S4 1/48 S4 2÷8/... ABOVE 20 STAGES S4 12/... S4 16/...	STAINLESS STEEL AISI 304
4	IMPELLER	TECHNOPOLYMER	
5	DIFFUSER	TECHNOPOLYMER	
6	OUTER SLEEVE	STAINLESS STEEL AISI 304	
7	THRUST BEARING	STAINLESS STEEL AISI 304	
8	SHAFT SLEEVE	STAINLESS STEEL AISI 304	
9	BUSH BEARING	RUBBER TPU	
10	UPPER SUPPORT	TECHNOPOLYMER	
11a	NON-RETURN VALVE	S4 1/13÷37 S4 2÷6/... UP TO 20 STAGES S4 8/5÷21 S4 12÷16/... UP TO 13 STAGES	TECHNOPOLYMER
11b		S4 1/48 S4 2÷6/... ABOVE 20 STAGES S4 8/27÷50 S4 12÷16/... ABOVE 13 STAGES	STAINLESS STEEL AISI 304 + RUBBER NBR
12	DELIVERY PORT	PRECISION CAST STEEL AISI 304	
13	CABLE SHEATH	STAINLESS STEEL AISI 304	
14	INTERMEDIATE SHAFT SLEEVE	STAINLESS STEEL AISI 304	
15	SHAFT WITH COUPLING	STAINLESS STEEL AISI 420	
16	FILTER	STAINLESS STEEL AISI 304	

* In contact with the liquid.

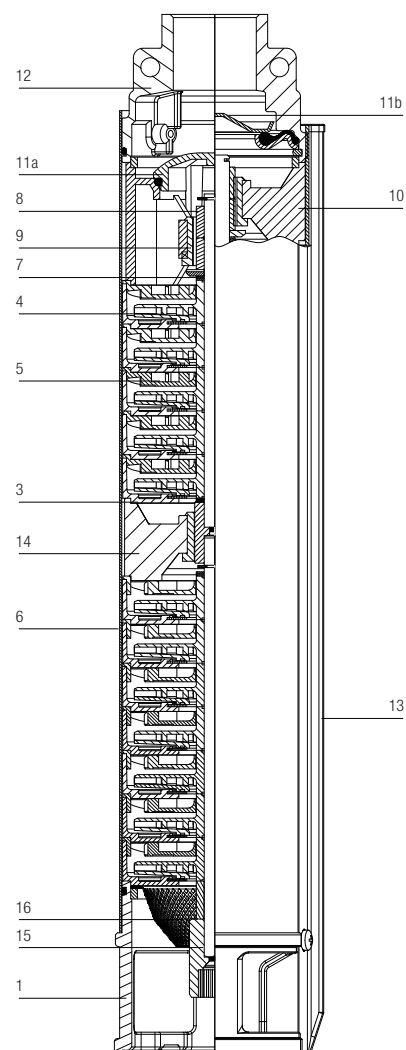

AVAILABLE AS STANDARD

Only pump body	Pump body with oil-filled motor	Pump body with water-filled motor
----------------	---------------------------------	-----------------------------------

Kit with pump body and motor, power supply cable, cord and control box.		
MODELS SUPPLIED WITH Power cable (and cord) 15 meters length	MODELS SUPPLIED WITH Power cable (and cord) 30 meters length	MODELS SUPPLIED WITH Power cable (and cord) 40 meters length
S4 1/13 S4 2/7 S4 2/10 S4 3/6 S4 3/9 S4 4/4 S4 4/7 S4 4/9 S4 6/5 S4 6/7 S4 8/5 S4 6/10 S4 8/7 S4 8/9 S4 12/6 S4 12/9 S4 12/13 S4 16/8 S4 16/12	S4 1/19 S4 1/26 S4 2/14 S4 3/13 S4 4/14 S4 6/14 S4 6/21 S4 8/15	S4 1/37 S4 1/48 S4 2/20 S4 2/28 S4 2/40 S4 3/19 S4 3/25 S4 3/32 S4 3/39 S4 4/19 S4 4/27

– Denomination index: (example)

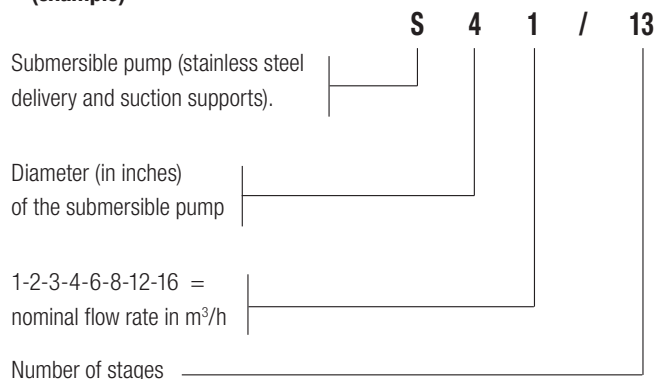

PERFORMANCE RANGE

The performance curves are based on kinematic viscosity values = 1 mm²/s and density equal to 1000 kg/m³. Curve tolerance according to ISO 9906.

GRAPHIC SELECTION TABLE

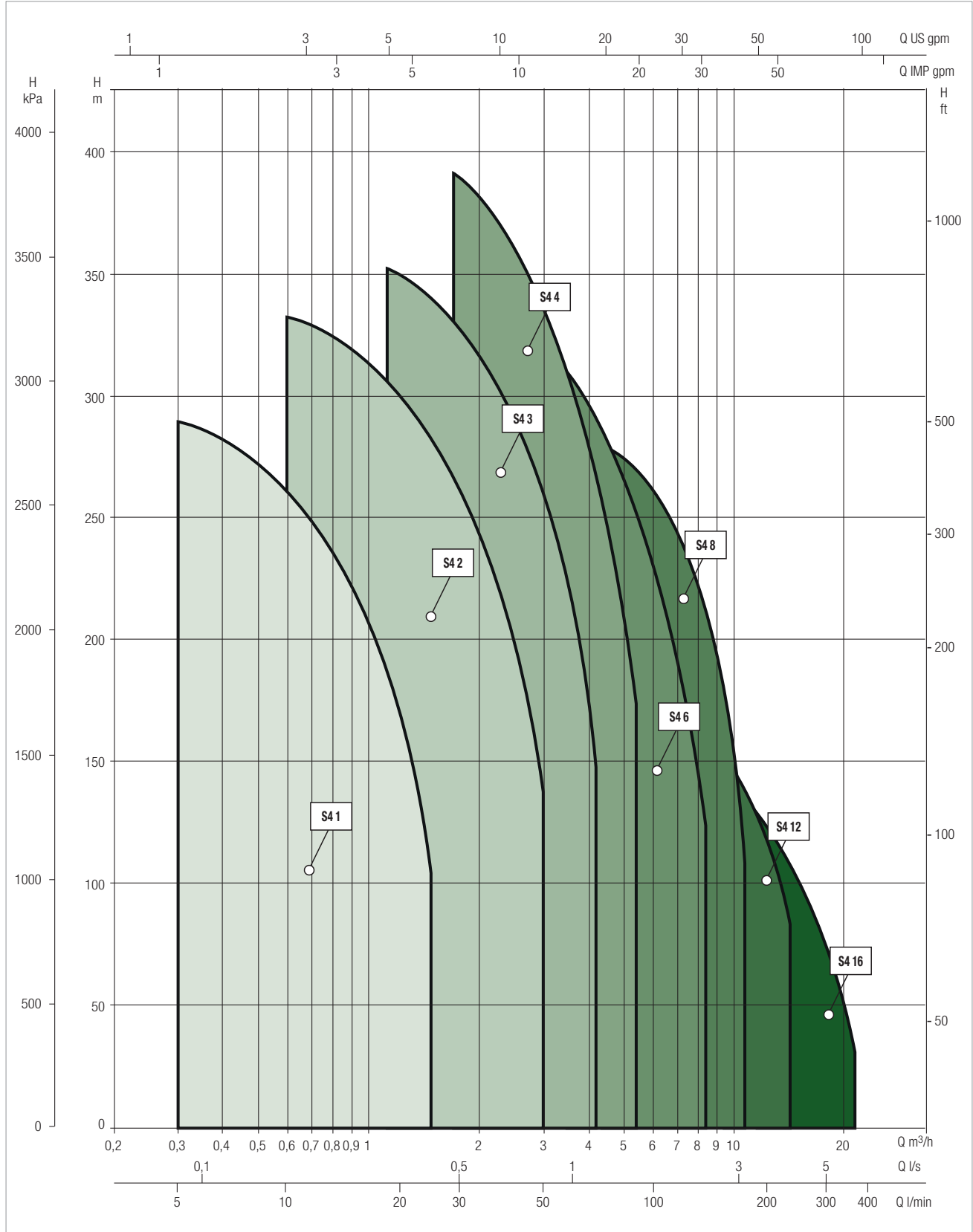

PERFORMANCE AT 50 Hz

MODEL	ELECTRICAL DATA		HYDRAULIC DATA																					
	P2 NOMINAL		Q=m³/h	0	0,3	0,6	0,9	1,2	1,5	1,8	2,4	3,0	4,2	5,4	6,0	7,2	8,4	9,6	10,8	12,0	14,4	16,8	19,2	21,6
	kW	HP	Q=l/min	0	5	10	15	20	25	30	40	50	70	90	100	120	140	160	180	200	240	280	320	360
S4 1/13	0,37	0,5	83	78	69	56	41	22																
S4 1/19	0,55	0,75	121	111	101	82	70	45																
S4 1/26	0,75	1	173	163	148	125	98	65																
S4 1/37	1,1	1,5	236	222	196	175	130	80																
S4 1/48	1,5	2	306	289	255	225	175	100																
S4 2/7	0,37	0,5	47		44	42	40	38	35	28	18													
S4 2/10	0,55	0,75	67		62	60	58	54	50	40	26													
S4 2/14	0,75	1	94		90	86	80	76	70	56	36													
S4 2/20	1,1	1,5	134		128	122	117	108	100	80	52													
S4 2/28	1,5	2	188		180	171	163	151	140	112	73													
S4 2/40	2,2	3	268		255	245	231	216	200	160	104													
S4 2/52	3	4	348		331	319	302	281	260	208	135													
S4 3/6	0,37	0,5	33				32	31	30	26	23	13												
S4 3/9	0,55	0,75	50				47	45	44	40	34	20												
S4 3/13	0,75	1	72				68	66	64	57	50	29												
S4 3/19	1,1	1,5	105				100	98	93	86	72	42												
S4 3/25	1,5	2	138				130	127	122	110	95	55												
S4 3/32	2,2	3	176				168	162	157	141	120	70												
S4 3/39	2,2	3	215				204	198	191	172	147	86												
S4 3/45	3	4	247				233	228	220	198	170	99												
S4 3/51	3	4	280				267	260	250	224	193	112												
S4 3/67	4	5,5	368				350	340	328	294	254	147												
S4 4/4	0,37	0,5	28						25	24	22	17	11											
S4 4/7	0,55	0,75	48						44	41	38	30	19											
S4 4/9	0,75	1	62						56	53	49	39	25											
S4 4/14	1,1	1,5	96						87	82	76	61	39											
S4 4/19	1,5	2	131						118	112	103	82	53											
S4 4/27	2,2	3	186						168	159	147	117	75											
S4 4/35	3	4	241						218	206	191	152	97											
S4 4/48	4	5,5	331						299	283	261	208	133											
S4 4/62	5,5	7,5	427						386	365	338	269	172											
S4 6/5	0,55	0,75	30							28	26	24	21	19	15	10								
S4 6/7	0,75	1	42							38	37	33	29	27	21	14								
S4 6/10	1,1	1,5	60							55	52	47	42	38	30	20								
S4 6/14	1,5	2	84							78	75	66	59	53	42	28								
S4 6/21	2,2	3	126							116	110	99	88	80	63	42								
S4 6/29	3	4	174							160	152	137	122	110	87	58								
S4 6/38	4	5,5	228							209	200	179	160	144	114	76								
S4 6/52	5,5	7,5	312							285	274	244	218	198	156	104								
S4 6/61	7,5	10	366							334	322	287	256	232	183	122								
S4 8/5	0,75	1	30								30	28	27	26	24	21	16	11						
S4 8/7	1,1	1,5	42								41	39	38	37	34	29	23	16						
S4 8/9	1,5	2	54								52	50	49	48	44	37	29	20						
S4 8/15	2,2	3	90								86	83	81	79	73	62	48	33						
S4 8/21	3	4	130								125	120	117	112	103	86	68	47						
S4 8/27	4	5,5	162								155	151	146	144	132	111	87	60						
S4 8/35	5,5	7,5	210								202	195	192	187	171	144	113	78						
S4 8/38	5,5	7,5	228								219	211	207	203	186	156	122	84						
S4 8/50	7,5	10	298								288	278	273	267	244	206	161	111						
S4 12/6	1,1	1,5	30											29	28	25	24	23	21	18	11			
S4 12/9	1,5	2	46											42	40	38	36	34	31	28	17			
S4 12/13	2,2	3	66											61	59	55	52	49	44	38	23			
S4 12/18	3	4	91											84	82	76	72	68	60	52	31			
S4 12/24	4	5,5	122											112	110	101	96	91	81	70	46			
S4 12/34	5,5	7,5	172											158	156	144	136	129	115	101	65			
S4 12/44	7,5	10	215											192	188	175	165	156	140	124	81			
S4 16/8	1,5	2	37															31	29	26	22	18	13	7
S4 16/12	2,2	3	55															46	43	39	33	27	19	10
S4 16/16	3	4	73															61	57	52	44	36	25	13
S4 16/21	4	5,5	96															81	75	68	58	47	33	18
S4 16/29	5,5	7,5	133															111	104	94	80	65	46	24
S4 16/38	7,5	10	174															146	136	124	105	86	60	32

H (m)

PERFORMANCE AT 50 Hz

MODEL	ELECTRICAL DATA		HYDRAULIC DATA						
	P2 NOMINAL		Q=m³/h	0	0,3	0,6	0,9	1,2	1,5
	kW	HP	Q=l/min	0	5	10	15	20	25
S4 1/13	0,37	0,5	H (m)	83	78	69	56	41	22
S4 1/19	0,55	0,75		121	111	101	82	70	45
S4 1/26	0,75	1		173	163	148	125	98	65
S4 1/37	1,1	1,5		236	222	196	175	130	80
S4 1/48	1,5	2		306	289	255	225	175	100

ELECTRICAL DATA AND DIMENSIONS

MODEL	ELECTRICAL DATA					Ø mm	H mm	DNM	PACKING DIMENSIONS			VOLUME m³	WEIGHT kg
	MOTOR	POWER INPUT 50 Hz	P2 NOMINAL		In A				L/A	L/B	H		
			kW	HP									
S4 1/13	40L M	1 x 230 V ~	0,37	0,5	3,5	99	722	1" 1/4	120	120	822	0,012	10,2
	40L T	3 x 230 V ~	0,37	0,5	2,1	99	722	1" 1/4	120	120	822	0,012	10,2
	40L T	3 x 400 V ~	0,37	0,5	1,2	99	722	1" 1/4	120	120	822	0,012	10,2
	4GG M	1 x 230 V ~	0,37	0,5	3,3	99	674	1" 1/4	110	110	720	0,009	10,6
	4GG T	3 x 230 V ~	0,37	0,5	2,7	99	654	1" 1/4	110	110	720	0,009	9,9
	4GG T	3 x 400 V ~	0,37	0,5	1,6	99	654	1" 1/4	110	110	720	0,009	9,9
S4 1/19	40L M	1 x 230 V ~	0,55	0,75	4,5	99	847	1" 1/4	120	120	947	0,014	12,1
	40L T	3 x 230 V ~	0,55	0,75	3,8	99	827	1" 1/4	120	120	927	0,013	11,2
	40L T	3 x 400 V ~	0,55	0,75	2,2	99	827	1" 1/4	120	120	927	0,013	11,2
	4GG M	1 x 230 V ~	0,55	0,75	4,6	99	809	1" 1/4	120	120	909	0,013	13,3
	4GG T	3 x 230 V ~	0,55	0,75	3,3	99	779	1" 1/4	120	120	879	0,013	11,6
	4GG T	3 x 400 V ~	0,55	0,75	1,9	99	779	1" 1/4	120	120	879	0,013	11,6
S4 1/26	40L M	1 x 230 V ~	0,75	1	6,3	99	1001	1" 1/4	120	120	1101	0,016	14,3
	40L T	3 x 230 V ~	0,75	1	4,5	99	971	1" 1/4	120	120	1071	0,015	13
	40L T	3 x 400 V ~	0,75	1	2,6	99	971	1" 1/4	120	120	1071	0,015	13
	4GG M	1 x 230 V ~	0,75	1	6,2	99	953	1" 1/4	120	120	1053	0,015	15,2
	4GG T	3 x 230 V ~	0,75	1	4,1	99	933	1" 1/4	120	120	1033	0,015	14,2
	4GG T	3 x 400 V ~	0,75	1	2,4	99	933	1" 1/4	120	120	1033	0,015	14,2
S4 1/37	40L M	1 x 230 V ~	1,1	1,5	8,5	99	1251	1" 1/4	120	120	1351	0,019	17
	40L T	3 x 230 V ~	1,1	1,5	6,2	99	1231	1" 1/4	120	120	1331	0,019	16
	40L T	3 x 400 V ~	1,1	1,5	3,6	99	1231	1" 1/4	120	120	1331	0,019	16
	4GG M	1 x 230 V ~	1,1	1,5	8,6	99	1228	1" 1/4	120	120	1328	0,019	19,1
	4GG T	3 x 230 V ~	1,1	1,5	5,5	99	1183	1" 1/4	120	120	1283	0,018	16,9
	4GG T	3 x 400 V ~	1,1	1,5	3,2	99	1183	1" 1/4	120	120	1283	0,018	16,9
S4 1/48	40L M	1 x 230 V ~	1,5	2	10,8	99	1492	1" 1/4	120	120	1592	0,023	20,4
	40L T	3 x 230 V ~	1,5	2	7,9	99	1446	1" 1/4	120	120	1546	0,022	18,4
	40L T	3 x 400 V ~	1,5	2	4,6	99	1446	1" 1/4	120	120	1546	0,022	18,4
	4GG M	1 x 230 V ~	1,5	2	11	99	1485	1" 1/4	120	120	1585	0,023	22,7
	4GG T	3 x 230 V ~	1,5	2	7,6	99	1440	1" 1/4	120	120	1540	0,022	20,5
	4GG T	3 x 400 V ~	1,5	2	4,4	99	1440	1" 1/4	120	120	1540	0,022	20,5

4GG: 4" encapsulated motor with stator immersed in thermosetting insulating resin.
 40L: 4" rewindable oil-filled motor.

S4 1

4" SUBMERSIBLE ELECTRIC PUMPS

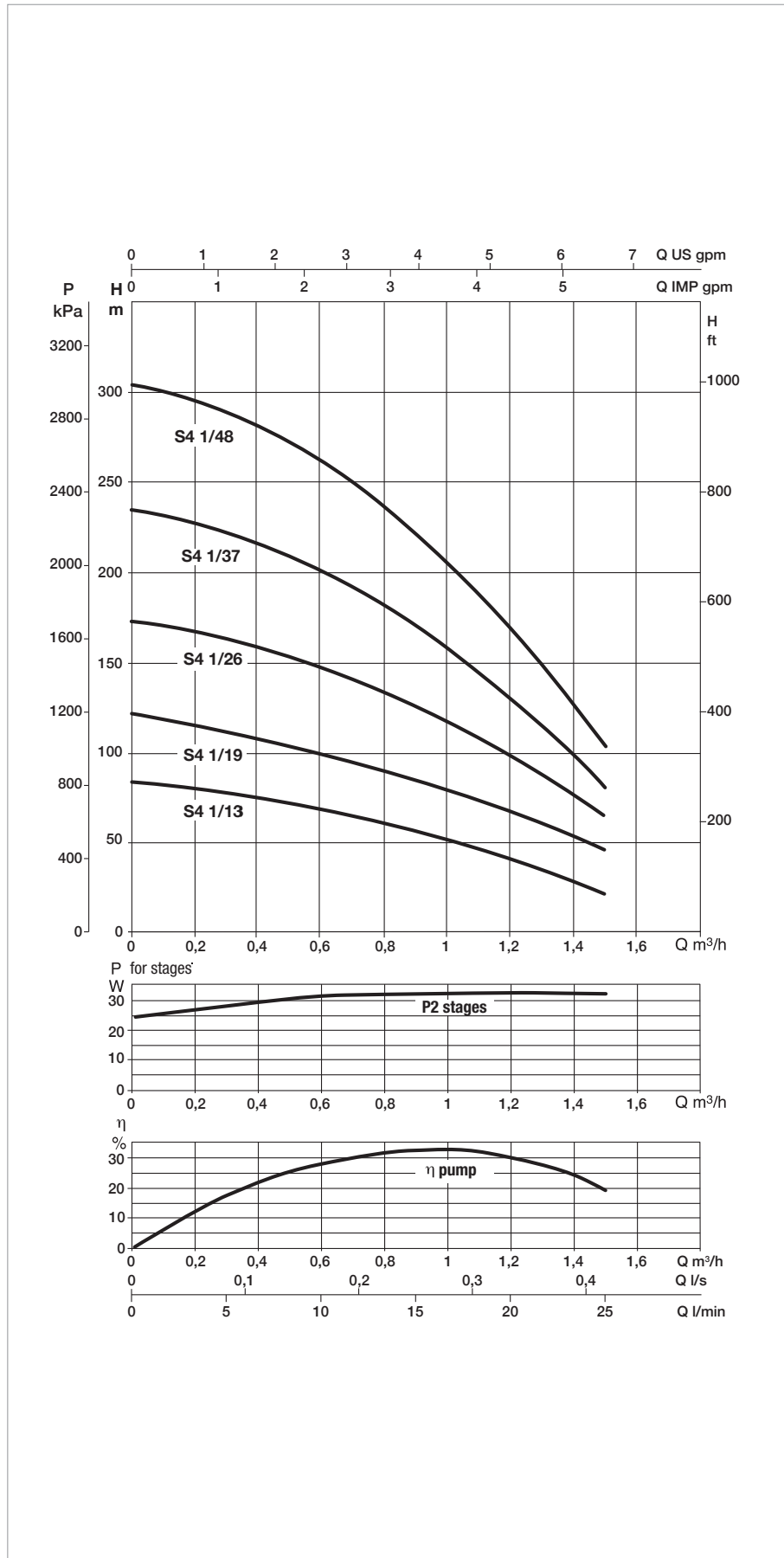
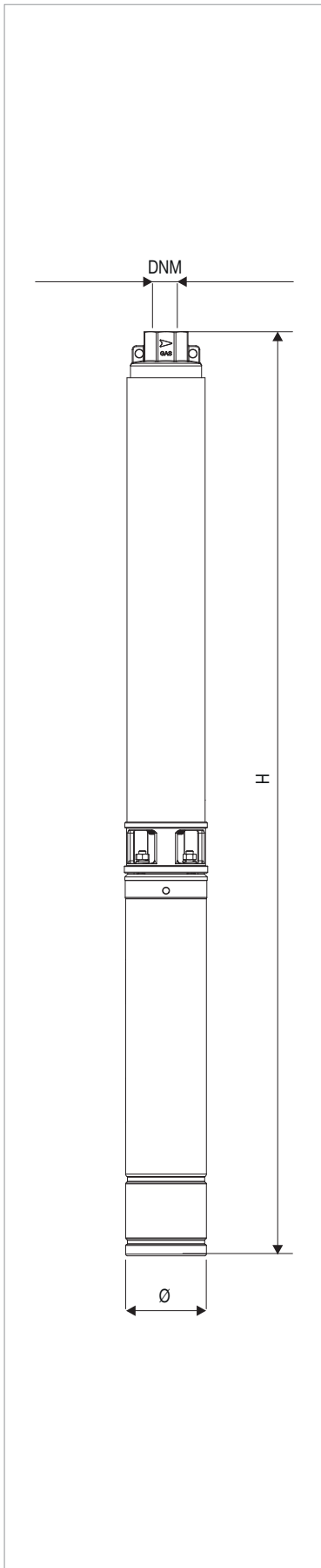

Performance at 50 Hz 2 poles. The performance curves are based on kinematic viscosity values = 1 mm²/s and density equal to 1000 kg/m³. Curve tolerance according to ISO 9906.

PERFORMANCE AT 50 Hz

MODEL	ELECTRICAL DATA		HYDRAULIC DATA								
	P2 NOMINAL		Q=m³/h	0	0,6	0,9	1,2	1,5	1,8	2,4	3,0
	kW	HP	Q=l/min	0	10	15	20	25	30	40	50
S4 2/7	0,37	0,5	H (m)	47	44	42	40	38	35	28	18
S4 2/10	0,55	0,75		67	62	60	58	54	50	40	26
S4 2/14	0,75	1		94	90	86	80	76	70	56	36
S4 2/20	1,1	1,5		134	128	122	117	108	100	80	52
S4 2/28	1,5	2		188	180	171	163	151	140	112	73
S4 2/40	2,2	3		268	255	245	231	216	200	160	104
S4 2/52	3	4		348	331	319	302	281	260	208	135

ELECTRICAL DATA AND DIMENSIONS

MODEL	ELECTRICAL DATA					Ø mm	H mm	DNM	PACKING DIMENSIONS			VOLUME m³	WEIGHT kg
	MOTOR	POWER INPUT 50 Hz	P2 NOMINAL		In A				L/A	L/B	H		
			kW	HP									
S4 2/7	40L M	1 x 230 V ~	0,37	0,5	3,5	99	642	1" 1/4	110	110	650	0,008	9,5
	40L T	3 x 230 V ~	0,37	0,5	2,1	99	642	1" 1/4	110	110	650	0,008	9,5
	40L T	3 x 400 V ~	0,37	0,5	1,2	99	642	1" 1/4	110	110	650	0,008	9,5
	4GG M	1 x 230 V ~	0,37	0,5	3,3	99	594	1" 1/4	110	110	650	0,008	9,9
	4GG T	3 x 230 V ~	0,37	0,5	2,7	99	574	1" 1/4	110	110	650	0,008	9,2
	4GG T	3 x 400 V ~	0,37	0,5	1,6	99	574	1" 1/4	110	110	650	0,008	9,2
S4 2/10	40L M	1 x 230 V ~	0,55	0,75	4,5	99	726	1" 1/4	120	120	826	0,012	10,9
	40L T	3 x 230 V ~	0,55	0,75	3,8	99	706	1" 1/4	110	110	720	0,009	10
	40L T	3 x 400 V ~	0,55	0,75	2,2	99	706	1" 1/4	110	110	720	0,009	10
	4GG M	1 x 230 V ~	0,55	0,75	4,6	99	688	1" 1/4	110	110	720	0,009	12,1
	4GG T	3 x 230 V ~	0,55	0,75	3,3	99	658	1" 1/4	110	110	720	0,009	10,4
	4GG T	3 x 400 V ~	0,55	0,75	1,9	99	658	1" 1/4	110	110	720	0,009	10,4
S4 2/14	40L M	1 x 230 V ~	0,75	1	6,3	99	840	1" 1/4	120	120	940	0,014	12,7
	40L T	3 x 230 V ~	0,75	1	4,5	99	810	1" 1/4	120	120	910	0,013	11,4
	40L T	3 x 400 V ~	0,75	1	2,6	99	810	1" 1/4	120	120	910	0,013	11,4
	4GG M	1 x 230 V ~	0,75	1	6,2	99	792	1" 1/4	120	120	892	0,013	13,6
	4GG T	3 x 230 V ~	0,75	1	4,1	99	772	1" 1/4	120	120	872	0,013	12,6
	4GG T	3 x 400 V ~	0,75	1	2,4	99	772	1" 1/4	120	120	872	0,013	12,6
S4 2/20	40L M	1 x 230 V ~	1,1	1,5	8,5	99	987	1" 1/4	120	120	1087	0,016	14,6
	40L T	3 x 230 V ~	1,1	1,5	6,2	99	967	1" 1/4	120	120	1067	0,015	13,6
	40L T	3 x 400 V ~	1,1	1,5	3,6	99	967	1" 1/4	120	120	1067	0,015	13,6
	4GG M	1 x 230 V ~	1,1	1,5	8,6	99	964	1" 1/4	120	120	1064	0,015	16,7
	4GG T	3 x 230 V ~	1,1	1,5	5,5	99	919	1" 1/4	120	120	1019	0,015	14,5
	4GG T	3 x 400 V ~	1,1	1,5	3,2	99	919	1" 1/4	120	120	1019	0,015	14,5
S4 2/28	40L M	1 x 230 V ~	1,5	2	10,8	99	1089	1" 1/4	120	120	1189	0,017	18,3
	40L T	3 x 230 V ~	1,5	2	7,9	99	1043	1" 1/4	120	120	1143	0,016	16,3
	40L T	3 x 400 V ~	1,5	2	4,6	99	1043	1" 1/4	120	120	1143	0,016	16,3
	4GG M	1 x 230 V ~	1,5	2	11	99	1082	1" 1/4	120	120	1182	0,017	20,6
	4GG T	3 x 230 V ~	1,5	2	7,6	99	1037	1" 1/4	120	120	1137	0,016	18,4
	4GG T	3 x 400 V ~	1,5	2	4,4	99	1037	1" 1/4	120	120	1137	0,016	18,4
S4 2/40	40L M	1 x 230 V ~	2,2	3	15	99	1421	1" 1/4	120	120	1521	0,022	23,8
	40L T	3 x 230 V ~	2,2	3	10,4	99	1401	1" 1/4	120	120	1501	0,022	22,7
	40L T	3 x 400 V ~	2,2	3	6	99	1401	1" 1/4	120	120	1501	0,022	22,7
	4GG M	1 x 230 V ~	2,2	3	15	99	1356	1" 1/4	120	120	1456	0,021	24
	4GG T	3 x 230 V ~	2,2	3	10,2	99	1336	1" 1/4	120	120	1436	0,021	23,3
	4GG T	3 x 400 V ~	2,2	3	5,9	99	1336	1" 1/4	120	120	1436	0,021	23,3
S4 2/52	40L T	3 x 230 V ~	3	4	13	99	1677	1" 1/4	120	120	1777	0,026	27,3
	40L T	3 x 400 V ~	3	4	7,5	99	1677	1" 1/4	120	120	1777	0,026	27,3
	4GG T	3 x 230 V ~	3	4	14,3	99	1703	1" 1/4	120	120	1803	0,026	31,9
	4GG T	3 x 400 V ~	3	4	8,3	99	1703	1" 1/4	120	120	1803	0,026	31,9

4GG: 4" encapsulated motor with stator immersed in thermosetting insulating resin.

40L: 4" rewindable oil-filled motor.

S4 2

4" SUBMERSIBLE ELECTRIC PUMPS

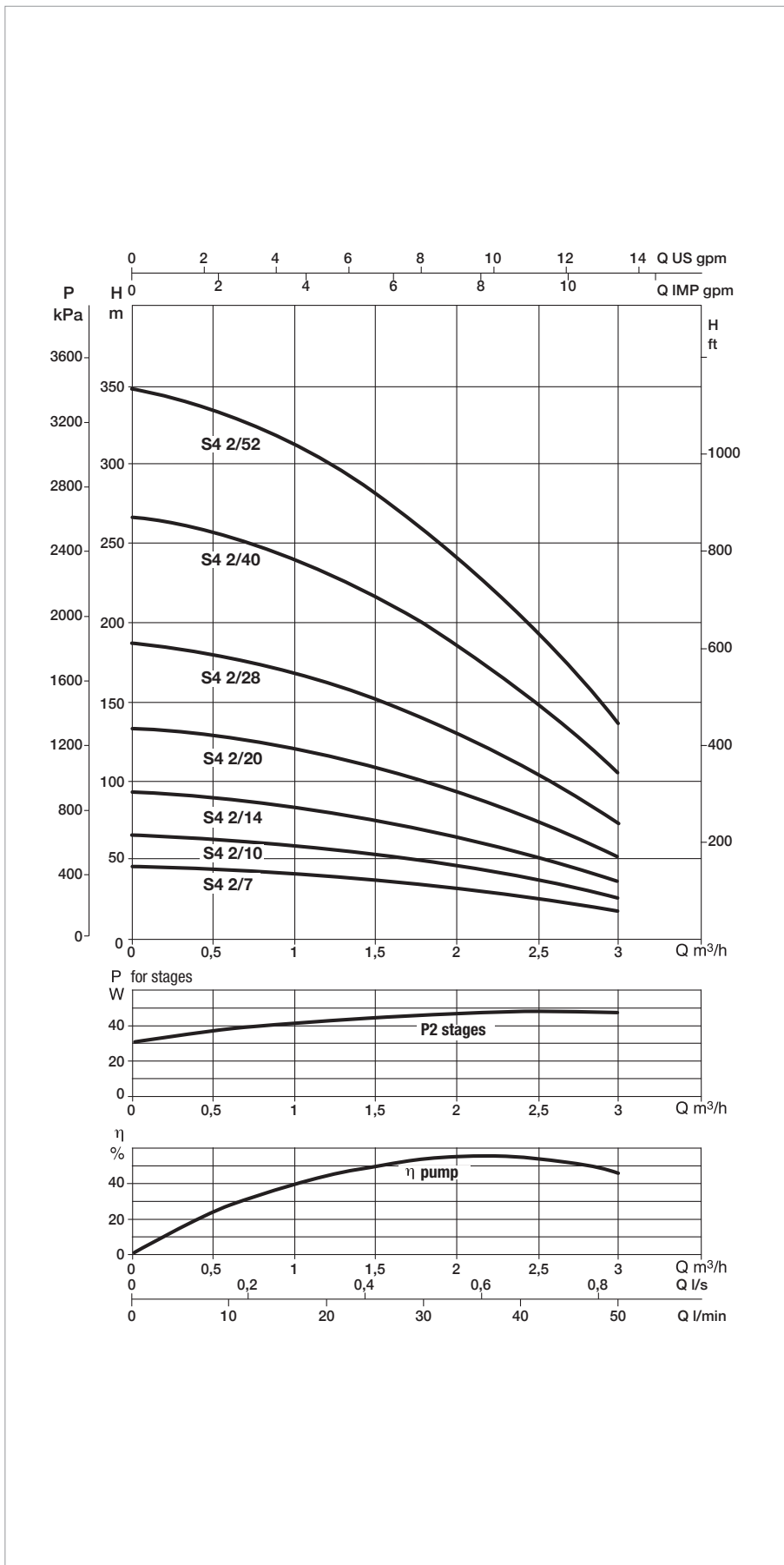
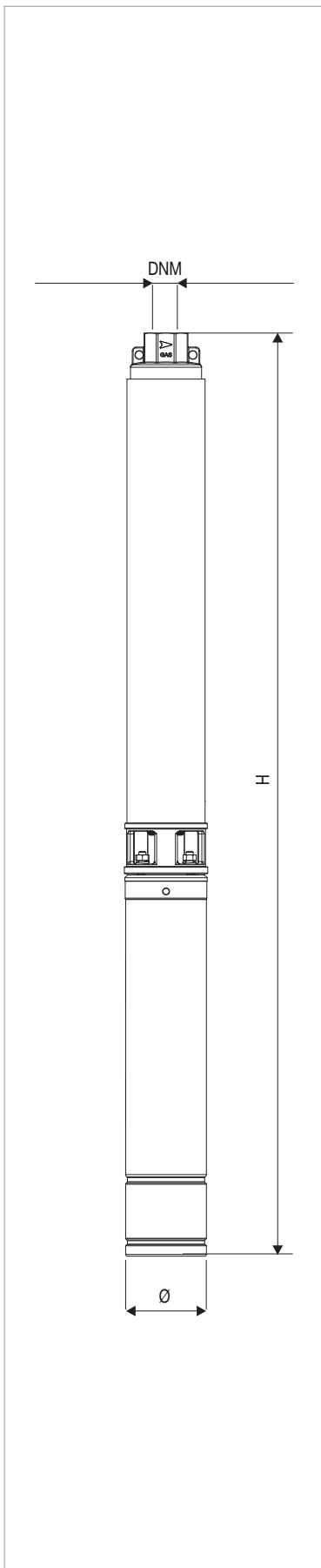

Performance at 50 Hz 2 poles. The performance curves are based on kinematic viscosity values = 1 mm²/s and density equal to 1000 kg/m³. Curve tolerance according to ISO 9906.

PERFORMANCE AT 50 Hz

MODEL	ELECTRICAL DATA		HYDRAULIC DATA							
	P2 NOMINAL		Q=m³/h	0	1,2	1,5	1,8	2,4	3,0	4,2
	kW	HP	Q=l/min	0	20	25	30	40	50	70
S4 3/6	0,37	0,5	H (m)	33	32	31	30	26	23	13
S4 3/9	0,55	0,75		50	47	45	44	40	34	20
S4 3/13	0,75	1		72	68	66	64	57	50	29
S4 3/19	1,1	1,5		105	100	98	93	86	72	42
S4 3/25	1,5	2		138	130	127	122	110	95	55
S4 3/32	2,2	3		176	168	162	157	141	120	70
S4 3/39	2,2	3		215	204	198	191	172	147	86
S4 3/45	3	4		247	233	228	220	198	170	99
S4 3/51	3	4		280	267	260	250	224	193	112
S4 3/67	4	5,5		368	350	340	328	294	254	147

ELECTRICAL DATA AND DIMENSIONS

MODEL	ELECTRICAL DATA					Ø mm	H mm	DNM	PACKING DIMENSIONS			VOLUME m³	WEIGHT kg
	MOTOR	POWER INPUT 50 Hz	P2 NOMINAL		In A				L/A	L/B	H		
			kW	HP									
S4 3/6	40L M	1 x 230 V ~	0,37	0,5	3,5	99	662	1" 1/4	110	110	720	0,009	9,7
	40L T	3 x 230 V ~	0,37	0,5	2,1	99	662	1" 1/4	110	110	720	0,009	9,7
	40L T	3 x 400 V ~	0,37	0,5	1,2	99	662	1" 1/4	110	110	720	0,009	9,7
	4GG M	1 x 230 V ~	0,37	0,5	3,3	99	614	1" 1/4	110	110	650	0,008	10,1
	4GG T	3 x 230 V ~	0,37	0,5	2,7	99	594	1" 1/4	110	110	650	0,008	9,4
	4GG T	3 x 400 V ~	0,37	0,5	1,6	99	594	1" 1/4	110	110	650	0,008	9,4
S4 3/9	40L M	1 x 230 V ~	0,55	0,75	4,5	99	765	1" 1/4	120	120	865	0,012	11,1
	40L T	3 x 230 V ~	0,55	0,75	3,8	99	745	1" 1/4	120	120	845	0,012	10,2
	40L T	3 x 400 V ~	0,55	0,75	2,2	99	745	1" 1/4	120	120	845	0,012	10,2
	4GG M	1 x 230 V ~	0,55	0,75	4,6	99	727	1" 1/4	120	120	827	0,012	12,3
	4GG T	3 x 230 V ~	0,55	0,75	3,3	99	697	1" 1/4	110	110	720	0,009	10,6
	4GG T	3 x 400 V ~	0,55	0,75	1,9	99	697	1" 1/4	110	110	720	0,009	10,6
S4 3/13	40L M	1 x 230 V ~	0,75	1	6,3	99	906	1" 1/4	120	120	1006	0,014	12,9
	40L T	3 x 230 V ~	0,75	1	4,5	99	876	1" 1/4	120	120	976	0,014	11,6
	40L T	3 x 400 V ~	0,75	1	2,6	99	876	1" 1/4	120	120	976	0,014	11,6
	4GG M	1 x 230 V ~	0,75	1	6,2	99	858	1" 1/4	120	120	958	0,014	13,8
	4GG T	3 x 230 V ~	0,75	1	4,1	99	838	1" 1/4	120	120	938	0,014	12,8
	4GG T	3 x 400 V ~	0,75	1	2,4	99	838	1" 1/4	120	120	938	0,014	12,8
S4 3/19	40L M	1 x 230 V ~	1,1	1,5	8,5	99	1093	1" 1/4	120	120	1193	0,017	15,2
	40L T	3 x 230 V ~	1,1	1,5	6,2	99	1073	1" 1/4	120	120	1173	0,017	14,2
	40L T	3 x 400 V ~	1,1	1,5	3,6	99	1073	1" 1/4	120	120	1173	0,017	14,2
	4GG M	1 x 230 V ~	1,1	1,5	8,6	99	1070	1" 1/4	120	120	1170	0,017	17,3
	4GG T	3 x 230 V ~	1,1	1,5	5,5	99	1025	1" 1/4	120	120	1125	0,016	15,1
	4GG T	3 x 400 V ~	1,1	1,5	3,2	99	1025	1" 1/4	120	120	1125	0,016	15,1
S4 3/25	40L M	1 x 230 V ~	1,5	2	10,8	99	1184	1" 1/4	120	120	1284	0,018	17,9
	40L T	3 x 230 V ~	1,5	2	7,9	99	1138	1" 1/4	120	120	1238	0,018	15,9
	40L T	3 x 400 V ~	1,5	2	4,6	99	1138	1" 1/4	120	120	1238	0,018	15,9
	4GG M	1 x 230 V ~	1,5	2	11	99	1177	1" 1/4	120	120	1277	0,018	20,2
	4GG T	3 x 230 V ~	1,5	2	7,6	99	1132	1" 1/4	120	120	1232	0,018	18
	4GG T	3 x 400 V ~	1,5	2	4,4	99	1132	1" 1/4	120	120	1232	0,018	18
S4 3/32	40L M	1 x 230 V ~	2,2	3	15	99	1465	1" 1/4	120	120	1565	0,023	22,2
	40L T	3 x 230 V ~	2,2	3	10,4	99	1445	1" 1/4	120	120	1545	0,022	21,1
	40L T	3 x 400 V ~	2,2	3	6	99	1445	1" 1/4	120	120	1545	0,022	21,1
	4GG M	1 x 230 V ~	2,2	3	15	99	1400	1" 1/4	120	120	1500	0,022	22,4
	4GG T	3 x 230 V ~	2,2	3	10,2	99	1380	1" 1/4	120	120	1480	0,021	19,5
	4GG T	3 x 400 V ~	2,2	3	5,9	99	1380	1" 1/4	120	120	1480	0,021	19,5
S4 3/39	40L M	1 x 230 V ~	2,2	3	15	99	1635	1" 1/4	120	120	1735	0,025	24,3
	40L T	3 x 230 V ~	2,2	3	10,4	99	1615	1" 1/4	120	120	1715	0,025	23,2
	40L T	3 x 400 V ~	2,2	3	6	99	1615	1" 1/4	120	120	1715	0,025	23,2
	4GG M	1 x 230 V ~	2,2	3	15	99	1570	1" 1/4	120	120	1670	0,024	24,5
	4GG T	3 x 230 V ~	2,2	3	10,2	99	1550	1" 1/4	120	120	1650	0,024	23,8
	4GG T	3 x 400 V ~	2,2	3	5,9	99	1550	1" 1/4	120	120	1650	0,024	23,8

4GG: 4" encapsulated motor with stator immersed in thermosetting insulating resin.

40L: 4" rewindable oil-filled motor.

ELECTRICAL DATA AND DIMENSIONS

MODEL	ELECTRICAL DATA					Ø mm	H mm	DNM	PACKING DIMENSIONS			VOLUME m³	WEIGHT kg
	MOTOR	POWER INPUT 50 Hz	P2 NOMINAL		In A				L/A	L/B	H		
			kW	HP									
S4 3/45	40LT	3 x 230 V ~	3	4	13	99	1819	1" 1/4	120	120	1919	0,028	27
	40LT	3 x 400 V ~	3	4	7,5	99	1819	1" 1/4	120	120	1919	0,028	27
	4GGT	3 x 230 V ~	3	4	14,3	99	1845	1" 1/4	120	120	1945	0,028	31,6
	4GGT	3 x 400 V ~	3	4	8,3	99	1845	1" 1/4	120	120	1945	0,028	31,6
S4 3/51	40LT	3 x 230 V ~	3	4	13	99	1964	1" 1/4	120	120	2064	0,030	28,3
	40LT	3 x 400 V ~	3	4	7,5	99	1964	1" 1/4	120	120	2064	0,030	28,3
	4GGT	3 x 230 V ~	3	4	14,3	99	1990	1" 1/4	120	120	2090	0,030	32,9
	4GGT	3 x 400 V ~	3	4	8,3	99	1990	1" 1/4	120	120	2090	0,030	32,9
S4 3/67	40LT	3 x 230 V ~	4	5,5	16,6	99	2415	1" 1/4	280	230	2820	0,182	56,3
	40LT	3 x 400 V ~	4	5,5	9,6	99	2415	1" 1/4	280	230	2820	0,182	56,3
	4GGT	3 x 230 V ~	4	5,5	17,3	99	2441	1" 1/4	280	230	2820	0,182	63
	4GGT	3 x 400 V ~	4	5,5	10	99	2441	1" 1/4	280	230	2820	0,182	63

4GG: 4" encapsulated motor with stator immersed in thermosetting insulating resin.
 40L: 4" rewindable oil-filled motor.

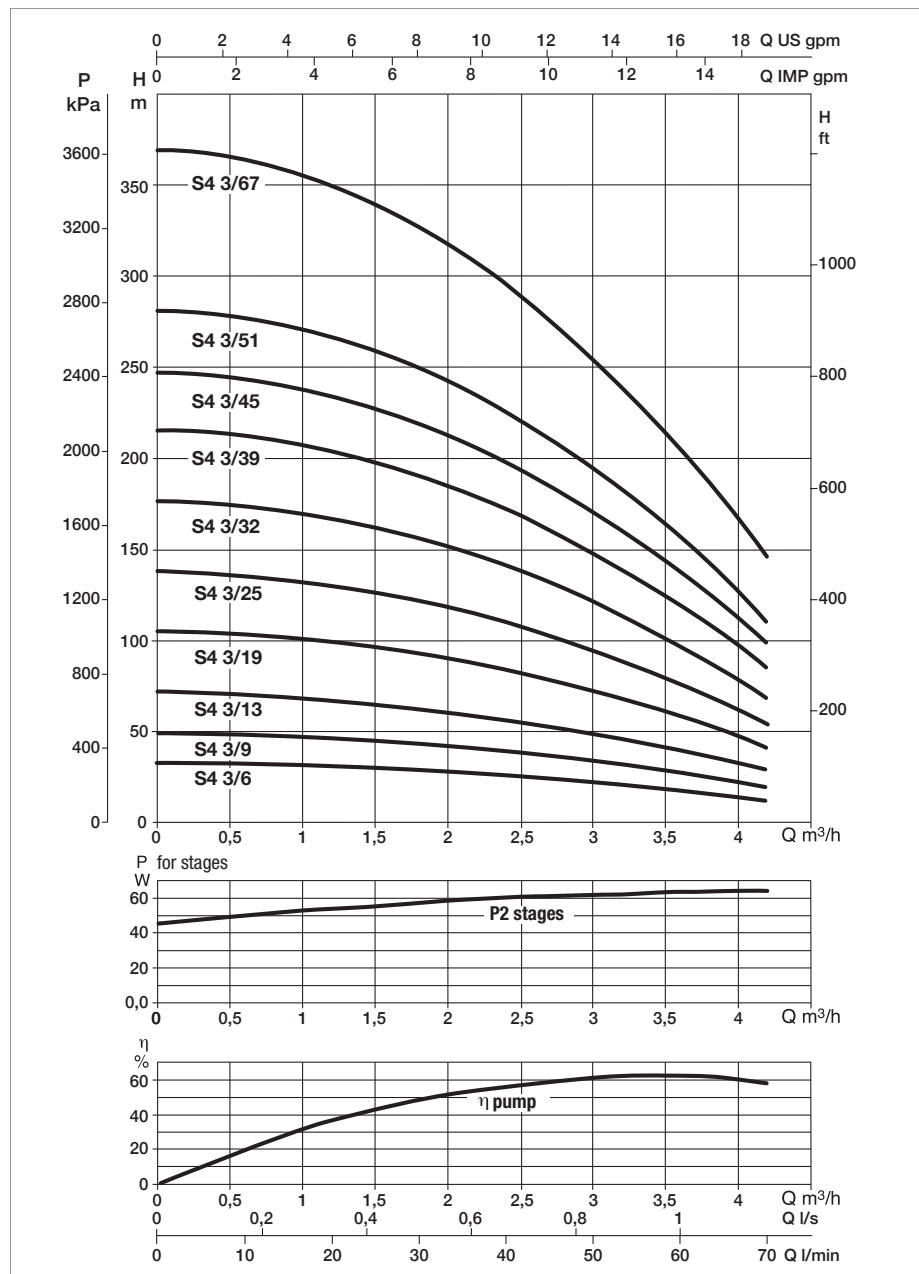
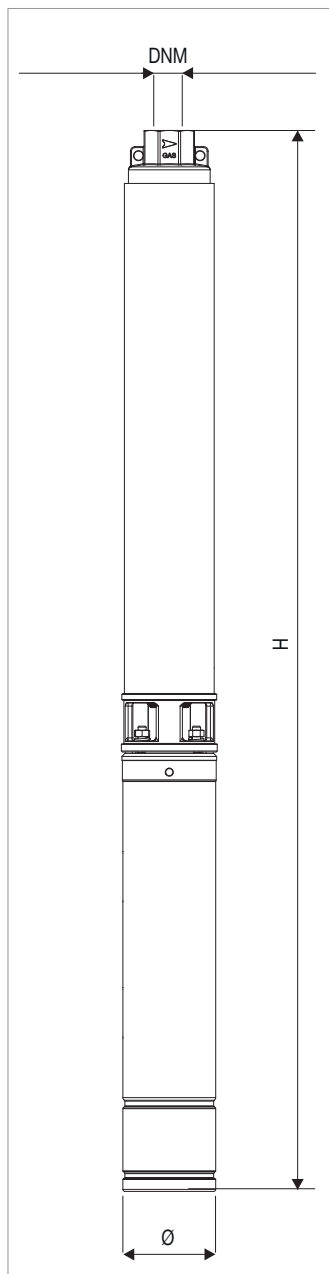

Performance at 50 Hz 2 poles. The performance curves are based on kinematic viscosity values = 1 mm²/s and density equal to 1000 kg/m³. Curve tolerance according to ISO 9906.

PERFORMANCE AT 50 Hz

MODEL	ELECTRICAL DATA		HYDRAULIC DATA						
	P2 NOMINAL		Q=m³/h	0	1,8	2,4	3,0	4,2	5,4
	kW	HP	Q=l/min	0	30	40	50	70	90
S4 4/4	0,37	0,5	H (m)	28	25	24	22	17	11
S4 4/7	0,55	0,75		48	44	41	38	30	19
S4 4/9	0,75	1		62	56	53	49	39	25
S4 4/14	1,1	1,5		96	87	82	76	61	39
S4 4/19	1,5	2		131	118	112	103	82	53
S4 4/27	2,2	3		186	168	159	147	117	75
S4 4/35	3	4		241	218	206	191	152	97
S4 4/48	4	5,5		331	299	283	261	208	133
S4 4/62	5,5	7,5		427	386	365	338	269	172

ELECTRICAL DATA AND DIMENSIONS

MODEL	ELECTRICAL DATA					Ø mm	H mm	DNM	PACKING DIMENSIONS			VOLUME m³	WEIGHT kg
	MOTOR	POWER INPUT 50 Hz	P2 NOMINAL		In A				L/A	L/B	H		
			kW	HP									
S4 4/4	40L M	1 x 230 V ~	0,37	0,5	3,5	99	597	1" 1/4	110	110	650	0,008	9,2
	40L T	3 x 230 V ~	0,37	0,5	2,1	99	597	1" 1/4	110	110	650	0,008	9,2
	40L T	3 x 400 V ~	0,37	0,5	1,2	99	597	1" 1/4	110	110	650	0,008	9,2
	4GG M	1 x 230 V ~	0,37	0,5	3,3	99	549	1" 1/4	110	110	650	0,008	9,6
	4GG T	3 x 230 V ~	0,37	0,5	2,7	99	529	1" 1/4	110	110	650	0,008	8,9
	4GG T	3 x 400 V ~	0,37	0,5	1,6	99	529	1" 1/4	110	110	650	0,008	8,9
S4 4/7	40L M	1 x 230 V ~	0,55	0,75	4,5	99	692	1" 1/4	110	110	720	0,009	10,6
	40L T	3 x 230 V ~	0,55	0,75	3,8	99	672	1" 1/4	110	110	720	0,009	9,7
	40L T	3 x 400 V ~	0,55	0,75	2,2	99	672	1" 1/4	110	110	720	0,009	9,7
	4GG M	1 x 230 V ~	0,55	0,75	4,6	99	654	1" 1/4	110	110	720	0,009	11,8
	4GG T	3 x 230 V ~	0,55	0,75	3,3	99	624	1" 1/4	110	110	650	0,008	10,1
	4GG T	3 x 400 V ~	0,55	0,75	1,9	99	624	1" 1/4	110	110	650	0,008	10,1
S4 4/9	40L M	1 x 230 V ~	0,75	1	6,3	99	774	1" 1/4	120	120	874	0,013	12,3
	40L T	3 x 230 V ~	0,75	1	4,5	99	744	1" 1/4	120	120	844	0,012	11
	40L T	3 x 400 V ~	0,75	1	2,6	99	744	1" 1/4	120	120	844	0,012	11
	4GG M	1 x 230 V ~	0,75	1	6,2	99	726	1" 1/4	120	120	826	0,012	13,2
	4GG T	3 x 230 V ~	0,75	1	4,1	99	706	1" 1/4	110	110	720	0,009	12,2
	4GG T	3 x 400 V ~	0,75	1	2,4	99	706	1" 1/4	110	110	720	0,009	12,2
S4 4/14	40L M	1 x 230 V ~	1,1	1,5	8,5	99	921	1" 1/4	120	120	1021	0,015	14,2
	40L T	3 x 230 V ~	1,1	1,5	6,2	99	901	1" 1/4	120	120	1001	0,014	13,2
	40L T	3 x 400 V ~	1,1	1,5	3,6	99	901	1" 1/4	120	120	1001	0,014	13,2
	4GG M	1 x 230 V ~	1,1	1,5	8,6	99	898	1" 1/4	120	120	998	0,014	16,3
	4GG T	3 x 230 V ~	1,1	1,5	5,5	99	853	1" 1/4	120	120	953	0,014	14,1
	4GG T	3 x 400 V ~	1,1	1,5	3,2	99	853	1" 1/4	120	120	953	0,014	14,1
S4 4/19	40L M	1 x 230 V ~	1,5	2	10,8	99	1094	1" 1/4	120	120	1194	0,017	17,5
	40L T	3 x 230 V ~	1,5	2	7,9	99	1048	1" 1/4	120	120	1148	0,017	15,5
	40L T	3 x 400 V ~	1,5	2	4,6	99	1048	1" 1/4	120	120	1148	0,017	15,5
	4GG M	1 x 230 V ~	1,5	2	11	99	1087	1" 1/4	120	120	1187	0,017	19,8
	4GG T	3 x 230 V ~	1,5	2	7,6	99	1042	1" 1/4	120	120	1142	0,016	17,6
	4GG T	3 x 400 V ~	1,5	2	4,4	99	1042	1" 1/4	120	120	1142	0,016	17,6
S4 4/27	40L M	1 x 230 V ~	2,2	3	15	99	1285	1" 1/4	120	120	1385	0,020	22,1
	40L T	3 x 230 V ~	2,2	3	10,4	99	1265	1" 1/4	120	120	1365	0,020	21
	40L T	3 x 400 V ~	2,2	3	6	99	1265	1" 1/4	120	120	1365	0,020	21
	4GG M	1 x 230 V ~	2,2	3	15	99	1220	1" 1/4	120	120	1320	0,019	22,3
	4GG T	3 x 230 V ~	2,2	3	10,2	99	1200	1" 1/4	120	120	1300	0,019	21,6
	4GG T	3 x 400 V ~	2,2	3	5,9	99	1200	1" 1/4	120	120	1300	0,019	21,6
S4 4/35	40L T	3 x 230 V ~	3	4	13	99	1499	1" 1/4	120	120	1599	0,023	25,1
	40L T	3 x 400 V ~	3	4	7,5	99	1499	1" 1/4	120	120	1599	0,023	25,1
	4GG T	3 x 230 V ~	3	4	14,3	99	1525	1" 1/4	120	120	1625	0,023	29,7
	4GG T	3 x 400 V ~	3	4	8,3	99	1525	1" 1/4	120	120	1625	0,023	29,7

4GG: 4" encapsulated motor with stator immersed in thermosetting insulating resin.

40L: 4" rewindable oil-filled motor.

ELECTRICAL DATA AND DIMENSIONS

MODEL	ELECTRICAL DATA					Ø mm	H mm	DNM	PACKING DIMENSIONS			VOLUME m³	WEIGHT kg
	MOTOR	POWER INPUT 50 Hz	P2 NOMINAL		In A								
			kW	HP									
S4 4/48	40LT	3 x 230 V ~	4	5,5	16,6	99	1851	1" 1/4	120	120	1951	0,028	28,9
	40LT	3 x 400 V ~	4	5,5	9,6	99	1851	1" 1/4	120	120	1951	0,028	28,9
	4GGT	3 x 230 V ~	4	5,5	17,3	99	1877	1" 1/4	120	120	1977	0,028	35,6
	4GGT	3 x 400 V ~	4	5,5	10	99	1877	1" 1/4	120	120	1977	0,028	35,6
S4 4/62	40LT	3 x 230 V ~	5,5	7,5	22,6	99	2225	1" 1/4	120	120	2325	0,033	38,3
	40LT	3 x 400 V ~	5,5	7,5	13,1	99	2225	1" 1/4	120	120	2325	0,033	38,3
	4GGT	3 x 230 V ~	5,5	7,5	24,2	99	2251	1" 1/4	120	120	2351	0,034	41,5
	4GGT	3 x 400 V ~	5,5	7,5	14	99	2251	1" 1/4	120	120	2351	0,034	41,5

4GG: 4" encapsulated motor with stator immersed in thermosetting insulating resin.

40L: 4" rewindable oil-filled motor.

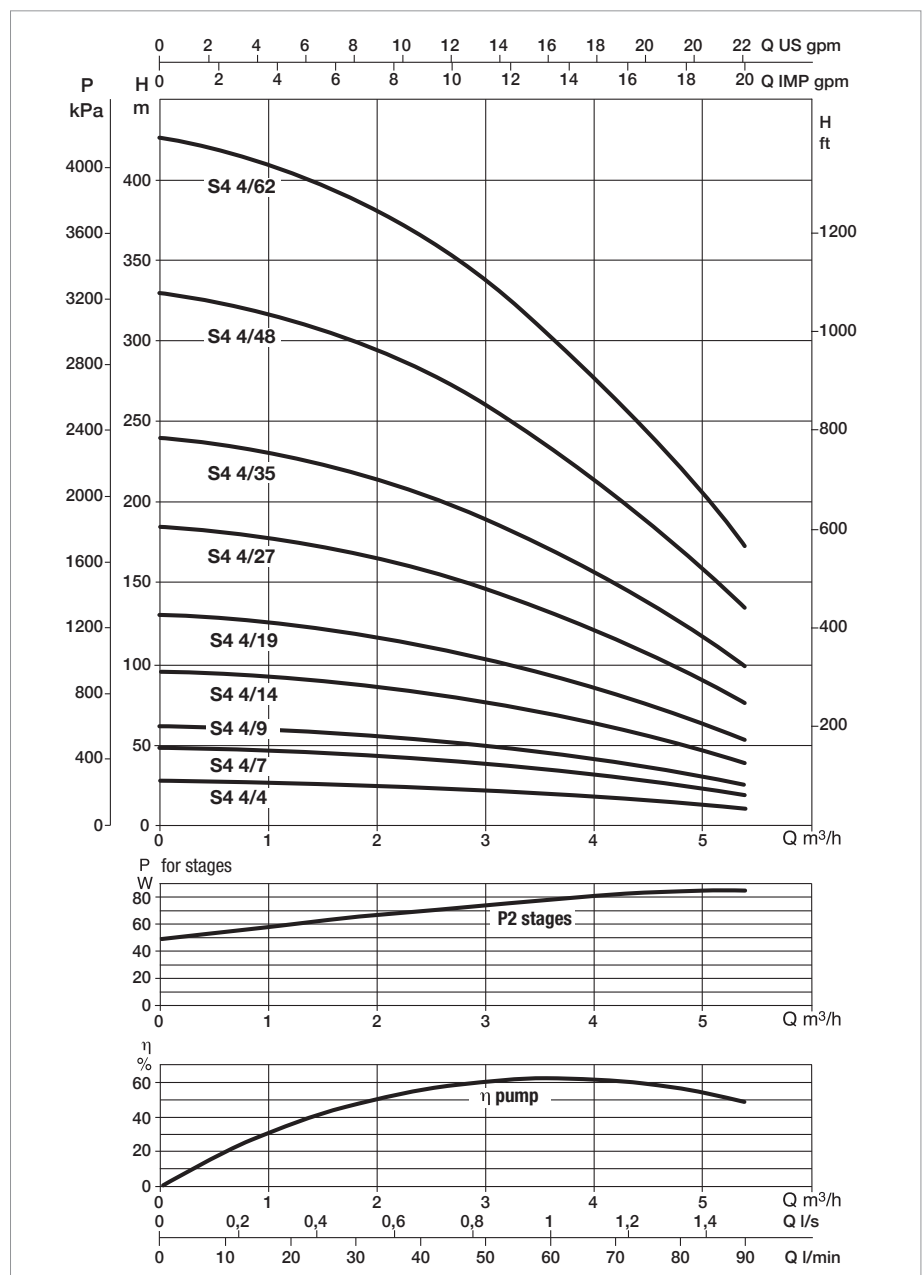
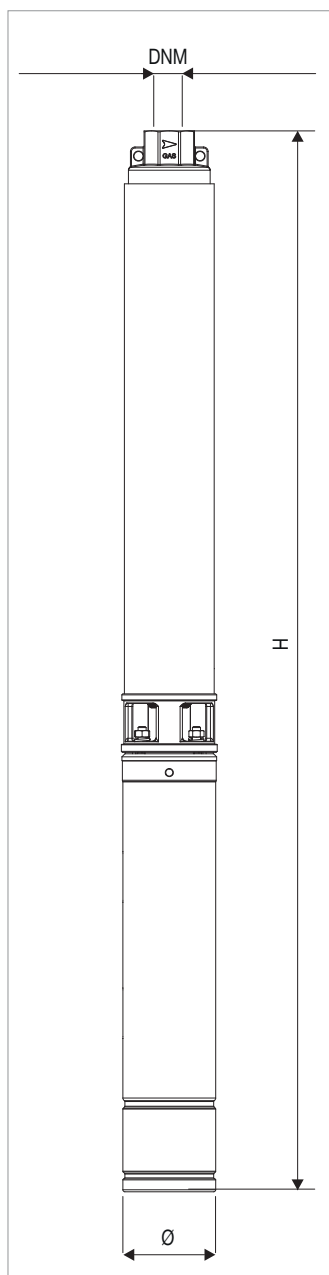

Performance at 50 Hz 2 poles. The performance curves are based on kinematic viscosity values = 1 mm²/s and density equal to 1000 kg/m³. Curve tolerance according to ISO 9906.

PERFORMANCE AT 50 Hz

MODEL	ELECTRICAL DATA		HYDRAULIC DATA								
	P2 NOMINAL		Q=m³/h	0	2,4	3,0	4,2	5,4	6,0	7,2	8,4
	kW	HP	Q=l/min	0	40	50	70	90	100	120	140
S4 6/5	0,55	0,75	H (m)	30	28	26	24	21	19	15	10
S4 6/7	0,75	1		42	38	37	33	29	27	21	14
S4 6/10	1,1	1,5		60	55	52	47	42	38	30	20
S4 6/14	1,5	2		84	78	75	66	59	53	42	28
S4 6/21	2,2	3		126	116	110	99	88	80	63	42
S4 6/29	3	4		174	160	152	137	122	110	87	58
S4 6/38	4	5,5		228	209	200	179	160	144	114	76
S4 6/52	5,5	7,5		312	285	274	244	218	198	156	104
S4 6/61	7,5	10		366	334	322	287	256	232	183	122

ELECTRICAL DATA AND DIMENSIONS

MODEL	ELECTRICAL DATA					Ø mm	H mm	DNM	PACKING DIMENSIONS			VOLUME m³	WEIGHT kg
	MOTOR	POWER INPUT 50 Hz	P2 NOMINAL		In A				L/A	L/B	H		
			kW	HP									
S4 6/5	40L M	1 x 230 V ~	0,55	0,75	4,5	99	678	1" 1/4	110	110	720	0,009	10,6
	40L T	3 x 230 V ~	0,55	0,75	3,8	99	658	1" 1/4	110	110	720	0,009	9,7
	40L T	3 x 400 V ~	0,55	0,75	2,2	99	658	1" 1/4	110	110	720	0,009	9,7
	4GG M	1 x 230 V ~	0,55	0,75	4,6	99	640	1" 1/4	110	110	650	0,008	11,8
	4GG T	3 x 230 V ~	0,55	0,75	3,3	99	610	1" 1/4	110	110	650	0,008	10,1
	4GG T	3 x 400 V ~	0,55	0,75	1,9	99	610	1" 1/4	110	110	650	0,008	10,1
S4 6/7	40L M	1 x 230 V ~	0,75	1	6,3	99	774	1" 1/4	120	120	874	0,013	12,3
	40L T	3 x 230 V ~	0,75	1	4,5	99	744	1" 1/4	120	120	844	0,012	11
	40L T	3 x 400 V ~	0,75	1	2,6	99	744	1" 1/4	120	120	844	0,012	11
	4GG M	1 x 230 V ~	0,75	1	6,2	99	726	1" 1/4	120	120	826	0,012	13,2
	4GG T	3 x 230 V ~	0,75	1	4,1	99	706	1" 1/4	110	110	720	0,009	12,2
	4GG T	3 x 400 V ~	0,75	1	2,4	99	706	1" 1/4	110	110	720	0,009	12,2
S4 6/10	40L M	1 x 230 V ~	1,1	1,5	8,5	99	893	1" 1/4	120	120	993	0,014	14
	40L T	3 x 230 V ~	1,1	1,5	6,2	99	873	1" 1/4	120	120	973	0,014	13
	40L T	3 x 400 V ~	1,1	1,5	3,6	99	873	1" 1/4	120	120	973	0,014	13
	4GG M	1 x 230 V ~	1,1	1,5	8,6	99	870	1" 1/4	120	120	970	0,014	16,1
	4GG T	3 x 230 V ~	1,1	1,5	5,5	99	825	1" 1/4	120	120	925	0,013	13,9
	4GG T	3 x 400 V ~	1,1	1,5	3,2	99	825	1" 1/4	120	120	925	0,013	13,9
S4 6/14	40L M	1 x 230 V ~	1,5	2	10,8	99	1072	1" 1/4	120	120	1172	0,017	16,8
	40L T	3 x 230 V ~	1,5	2	7,9	99	1026	1" 1/4	120	120	1126	0,016	14,8
	40L T	3 x 400 V ~	1,5	2	4,6	99	1026	1" 1/4	120	120	1126	0,016	14,8
	4GG M	1 x 230 V ~	1,5	2	11	99	1065	1" 1/4	120	120	1165	0,017	19,1
	4GG T	3 x 230 V ~	1,5	2	7,6	99	1020	1" 1/4	120	120	1120	0,016	16,9
	4GG T	3 x 400 V ~	1,5	2	4,4	99	1020	1" 1/4	120	120	1120	0,016	16,9
S4 6/21	40L M	1 x 230 V ~	2,2	3	15	99	1350	1" 1/4	120	120	1450	0,021	22,3
	40L T	3 x 230 V ~	2,2	3	10,4	99	1330	1" 1/4	120	120	1430	0,021	21,2
	40L T	3 x 400 V ~	2,2	3	6	99	1330	1" 1/4	120	120	1430	0,021	21,2
	4GG M	1 x 230 V ~	2,2	3	15	99	1285	1" 1/4	120	120	1385	0,020	22,5
	4GG T	3 x 230 V ~	2,2	3	10,2	99	1265	1" 1/4	120	120	1365	0,020	21,8
	4GG T	3 x 400 V ~	2,2	3	5,9	99	1265	1" 1/4	120	120	1365	0,020	21,8
S4 6/29	40L T	3 x 230 V ~	3	4	13	99	1638	1" 1/4	120	120	1738	0,025	25,8
	40L T	3 x 400 V ~	3	4	7,5	99	1638	1" 1/4	120	120	1738	0,025	25,8
	4GG T	3 x 230 V ~	3	4	14,3	99	1664	1" 1/4	120	120	1764	0,025	30,4
	4GG T	3 x 400 V ~	3	4	8,3	99	1664	1" 1/4	120	120	1764	0,025	30,4
S4 6/38	40L T	3 x 230 V ~	4	5,5	16,6	99	1987	1" 1/4	120	120	2087	0,030	29,4
	40L T	3 x 400 V ~	4	5,5	9,6	99	1987	1" 1/4	120	120	2087	0,030	29,4
	4GG T	3 x 230 V ~	4	5,5	17,3	99	2013	1" 1/4	120	120	2113	0,030	36,1
	4GG T	3 x 400 V ~	4	5,5	10	99	2013	1" 1/4	120	120	2113	0,030	36,1

4GG: 4" encapsulated motor with stator immersed in thermosetting insulating resin.

40L: 4" rewindable oil-filled motor.

ELECTRICAL DATA AND DIMENSIONS

MODEL	ELECTRICAL DATA					Ø mm	H mm	DNM	PACKING DIMENSIONS			VOLUME m ³	WEIGHT kg
	MOTOR	POWER INPUT 50 Hz	P2 NOMINAL		In A				L/A	L/B	H		
			kW	HP									
S4 6/52	40LT	3 x 230 V ~	5,5	7,5	22,6	99	2528	1" 1/4	280	230	2820	0,182	63,4
	40LT	3 x 400 V ~	5,5	7,5	13,1	99	2528	1" 1/4	280	230	2820	0,182	63,4
	4GGT	3 x 230 V ~	5,5	7,5	24,2	99	2554	1" 1/4	280	230	2820	0,182	66,6
	4GGT	3 x 400 V ~	5,5	7,5	14	99	2554	1" 1/4	280	230	2820	0,182	66,6
S4 6/61	40LT	3 x 230 V ~	7,5	10	29,2	99	2886	1" 1/4	280	230	3080	0,198	72,1
	40LT	3 x 400 V ~	7,5	10	16,9	99	2886	1" 1/4	280	230	3080	0,198	72,1
	4GGT	3 x 230 V ~	7,5	10	30,1	99	2936	1" 1/4	280	230	3080	0,198	75
	4GGT	3 x 400 V ~	7,5	10	17,4	99	2936	1" 1/4	280	230	3080	0,198	75

4GG: 4" encapsulated motor with stator immersed in thermosetting insulating resin.

40L: 4" rewindable oil-filled motor.

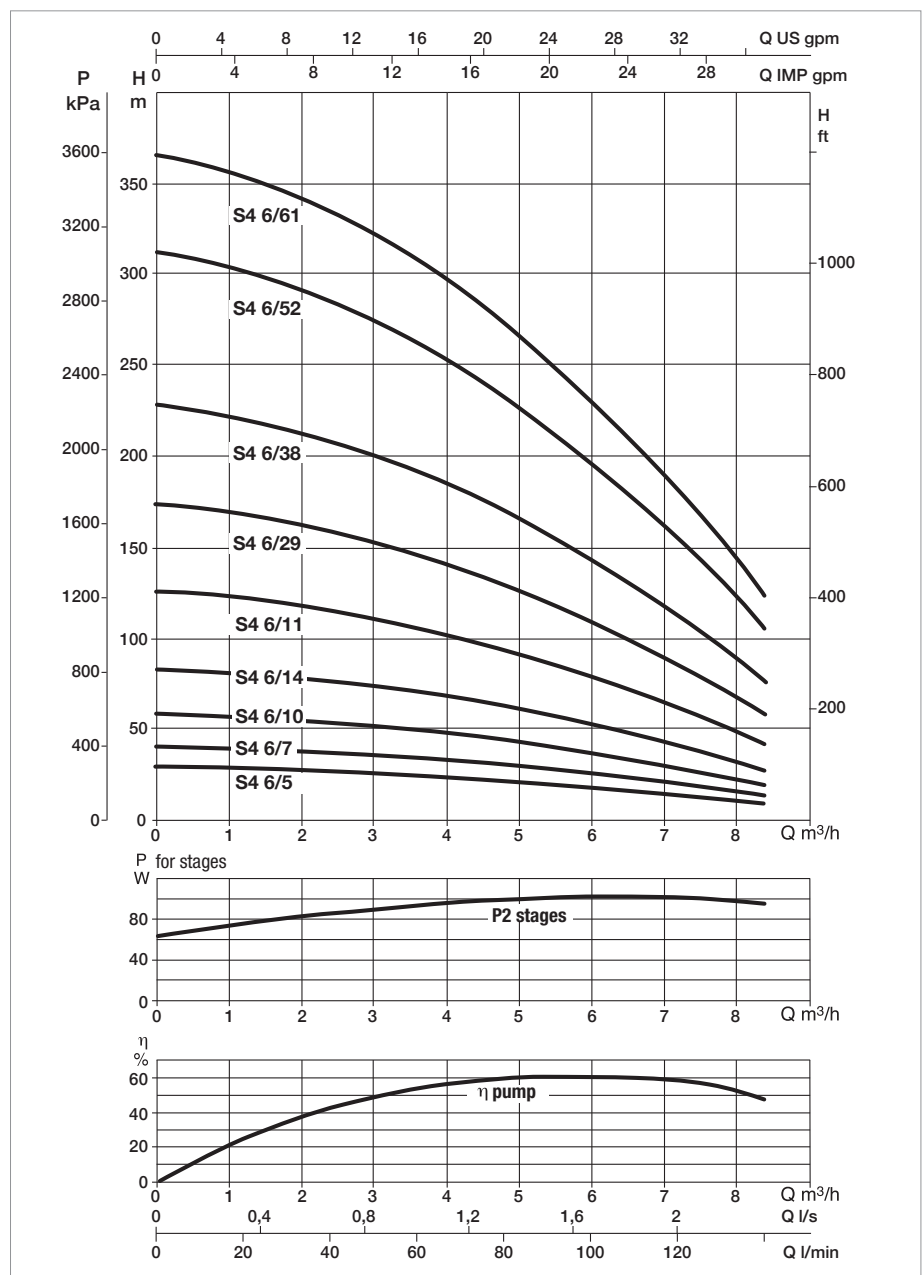
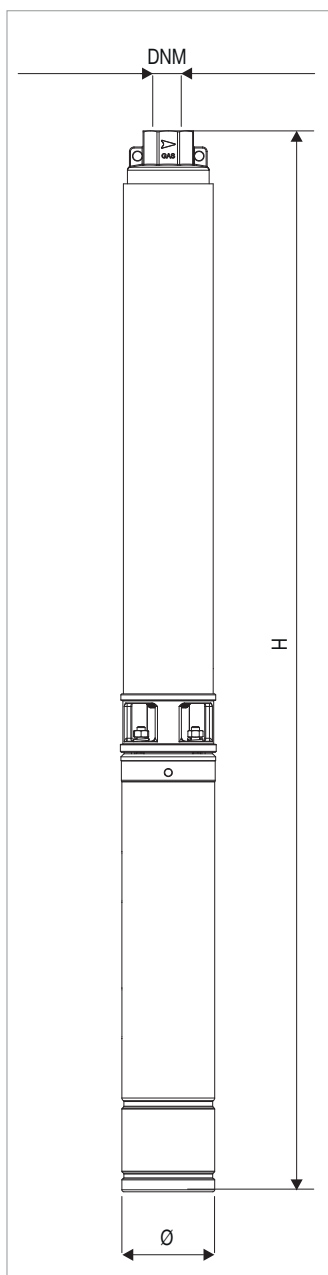

Performance at 50 Hz 2 poles. The performance curves are based on kinematic viscosity values = 1 mm²/s and density equal to 1000 kg/m³. Curve tolerance according to ISO 9906.

PERFORMANCE AT 50 Hz

MODEL	ELECTRICAL DATA		HYDRAULIC DATA									
	P2 NOMINAL		Q=m³/h	0	3,0	4,2	5,4	6,0	7,2	8,4	9,6	10,8
	kW	HP	Q=l/min	0	50	70	90	100	120	140	160	180
S4 8/5	0,75	1	H (m)	30	30	28	27	26	24	21	16	11
S4 8/7	1,1	1,5		42	41	39	38	37	34	29	23	16
S4 8/9	1,5	2		54	52	50	49	48	44	37	29	20
S4 8/15	2,2	3		90	86	83	81	79	73	62	48	33
S4 8/21	3	4		130	125	120	117	112	103	86	68	47
S4 8/27	4	5,5		162	155	151	146	144	132	111	87	60
S4 8/35	5,5	7,5		210	202	195	192	187	171	144	113	78
S4 8/38	5,5	7,5		228	219	211	207	203	186	156	122	84
S4 8/50	7,5	10		298	288	278	273	267	244	206	161	111

ELECTRICAL DATA AND DIMENSIONS

MODEL	ELECTRICAL DATA					Ø mm	H mm	DNM	PACKING DIMENSIONS			VOLUME m³	WEIGHT kg
	MOTOR	POWER INPUT 50 Hz	P2 NOMINAL		In A				L/A	L/B	H		
			kW	HP									
S4 8/5	40L M	1 x 230 V ~	0,75	1	6,3	99	784	2"	120	120	884	0,013	12,5
	40L T	3 x 230 V ~	0,75	1	4,5	99	754	2"	120	120	854	0,012	11,2
	40L T	3 x 400 V ~	0,75	1	2,6	99	754	2"	120	120	854	0,012	11,2
	4GG M	1 x 230 V ~	0,75	1	6,2	99	736	2"	120	120	836	0,012	13,4
	4GG T	3 x 230 V ~	0,75	1	4,1	99	716	2"	110	110	720	0,009	12,4
	4GG T	3 x 400 V ~	0,75	1	2,4	99	716	2"	110	110	720	0,009	12,4
S4 8/7	40L M	1 x 230 V ~	1,1	1,5	8,5	99	895	2"	120	120	995	0,014	14,2
	40L T	3 x 230 V ~	1,1	1,5	6,2	99	875	2"	120	120	975	0,014	13,2
	40L T	3 x 400 V ~	1,1	1,5	3,6	99	875	2"	120	120	975	0,014	13,2
	4GG M	1 x 230 V ~	1,1	1,5	8,6	99	872	2"	120	120	972	0,014	16,3
	4GG T	3 x 230 V ~	1,1	1,5	5,5	99	827	2"	120	120	927	0,013	14,1
	4GG T	3 x 400 V ~	1,1	1,5	3,2	99	827	2"	120	120	927	0,013	14,1
S4 8/9	40L M	1 x 230 V ~	1,5	2	10,8	99	1031	2"	120	120	1131	0,016	16,8
	40L T	3 x 230 V ~	1,5	2	7,9	99	985	2"	120	120	1085	0,016	14,8
	40L T	3 x 400 V ~	1,5	2	4,6	99	985	2"	120	120	1085	0,016	14,8
	4GG M	1 x 230 V ~	1,5	2	11	99	1024	2"	120	120	1124	0,016	19,1
	4GG T	3 x 230 V ~	1,5	2	7,6	99	979	2"	120	120	1079	0,016	16,9
	4GG T	3 x 400 V ~	1,5	2	4,4	99	979	2"	120	120	1079	0,016	16,9
S4 8/15	40L M	1 x 230 V ~	2,2	3	15	99	1419	2"	120	120	1519	0,022	21,7
	40L T	3 x 230 V ~	2,2	3	10,4	99	1399	2"	120	120	1499	0,022	20,6
	40L T	3 x 400 V ~	2,2	3	6	99	1399	2"	120	120	1499	0,022	20,6
	4GG M	1 x 230 V ~	2,2	3	15	99	1354	2"	120	120	1454	0,021	21,9
	4GG T	3 x 230 V ~	2,2	3	10,2	99	1334	2"	120	120	1434	0,021	21,2
	4GG T	3 x 400 V ~	2,2	3	5,9	99	1334	2"	120	120	1434	0,021	21,2
S4 8/21	40L T	3 x 230 V ~	3	4	13	99	1732	2"	120	120	1832	0,026	24,9
	40L T	3 x 400 V ~	3	4	7,5	99	1732	2"	120	120	1832	0,026	24,9
	4GG T	3 x 230 V ~	3	4	14,3	99	1758	2"	120	120	1858	0,027	29,5
	4GG T	3 x 400 V ~	3	4	8,3	99	1758	2"	120	120	1858	0,027	29,5
S4 8/27	40L T	3 x 230 V ~	4	5,5	16,6	99	1845	2"	120	120	1945	0,028	29,5
	40L T	3 x 400 V ~	4	5,5	9,6	99	1845	2"	120	120	1945	0,028	29,5
	4GG T	3 x 230 V ~	4	5,5	17,3	99	1871	2"	120	120	1971	0,028	36,2
	4GG T	3 x 400 V ~	4	5,5	10	99	1871	2"	120	120	1971	0,028	36,2
S4 8/35	40L T	3 x 230 V ~	5,5	7,5	22,6	99	2293	2"	120	120	2393	0,034	38,6
	40L T	3 x 400 V ~	5,5	7,5	13,1	99	2293	2"	120	120	2393	0,034	38,6
	4GG T	3 x 230 V ~	5,5	7,5	24,2	99	2319	2"	120	120	2419	0,035	41,8
	4GG T	3 x 400 V ~	5,5	7,5	14	99	2319	2"	120	120	2419	0,035	41,8

4GG: 4" encapsulated motor with stator immersed in thermosetting insulating resin.

40L: 4" rewindable oil-filled motor.

ELECTRICAL DATA AND DIMENSIONS

MODEL	ELECTRICAL DATA					Ø mm	H mm	DNM	PACKING DIMENSIONS			VOLUME m³	WEIGHT kg
	MOTOR	POWER INPUT 50 Hz	P2 NOMINAL		In A				L/A	L/B	H		
			kW	HP									
S4 8/38	40LT	3 x 230 V ~	5,5	7,5	22,6	99	2555	2"	280	230	2820	0,182	63,4
	40LT	3 x 400 V ~	5,5	7,5	13,1	99	2555	2"	280	230	2820	0,182	63,4
	4GGT	3 x 230 V ~	5,5	7,5	24,2	99	2581	2"	280	230	2820	0,182	66,6
	4GGT	3 x 400 V ~	5,5	7,5	14	99	2581	2"	280	230	2820	0,182	66,6
S4 8/50	40LT	3 x 230 V ~	7,5	10	29,2	99	3011	2"	280	230	3380	0,218	75,3
	40LT	3 x 400 V ~	7,5	10	16,9	99	3011	2"	280	230	3380	0,218	75,3
	4GGT	3 x 230 V ~	7,5	10	30,1	99	3172	2"	280	230	3380	0,218	78,2
	4GGT	3 x 400 V ~	7,5	10	17,4	99	3172	2"	280	230	3380	0,218	78,2

4GG: 4" encapsulated motor with stator immersed in thermosetting insulating resin.

40L: 4" rewindable oil-filled motor.

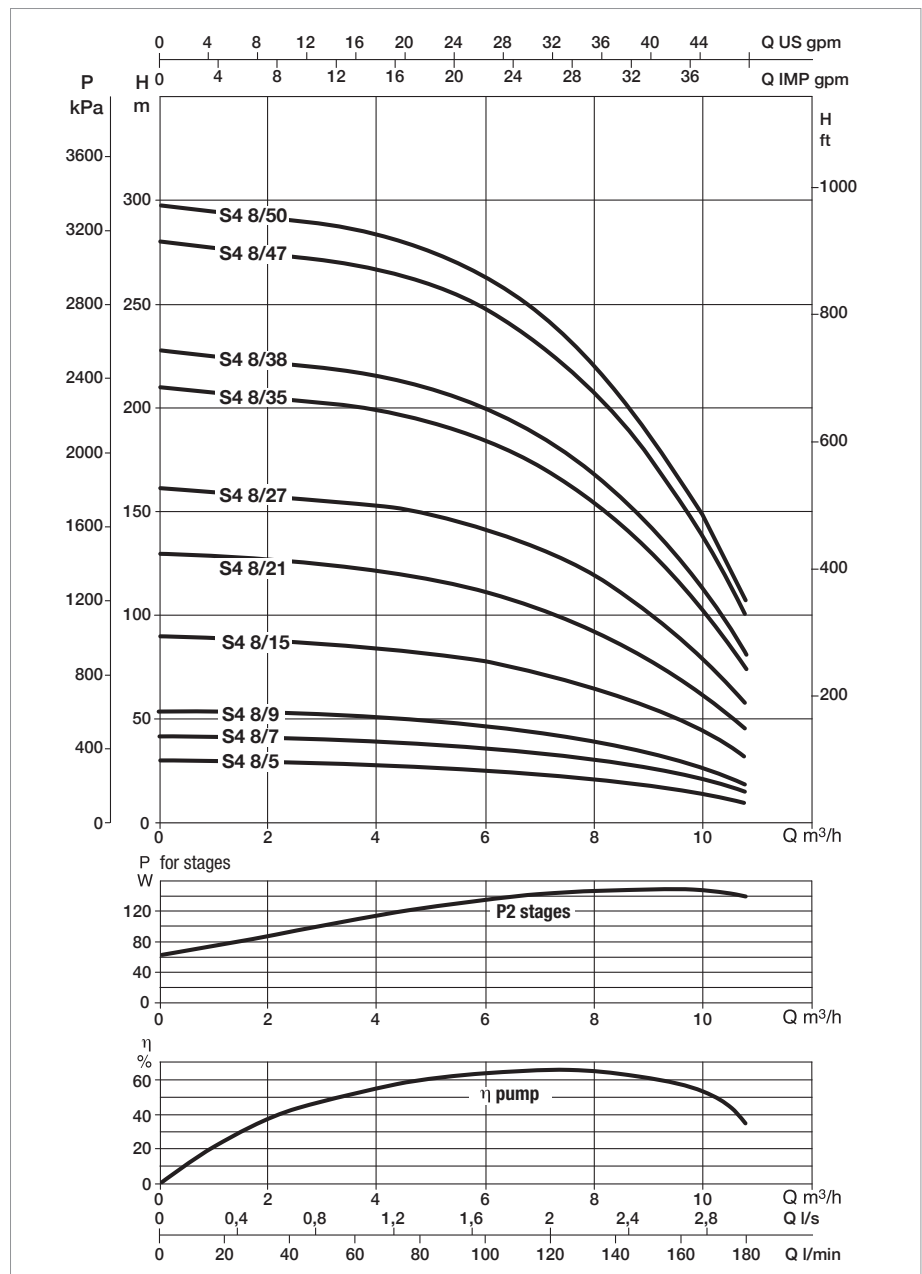
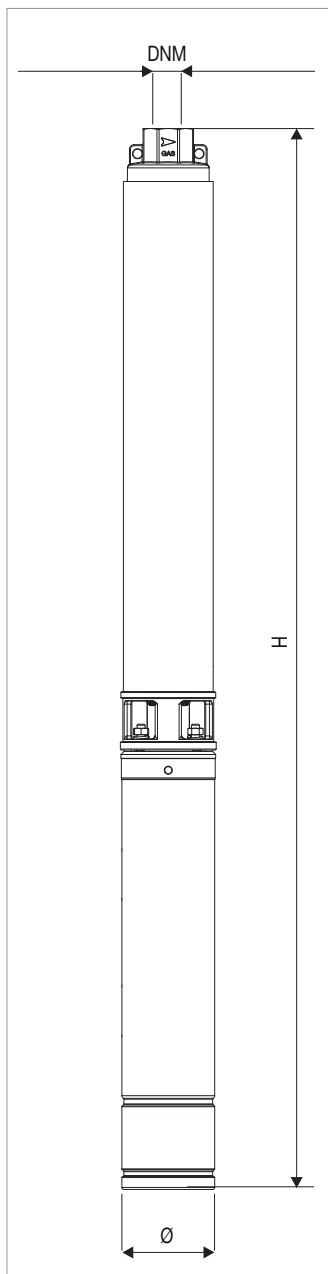

Performance at 50 Hz 2 poles. The performance curves are based on kinematic viscosity values = 1 mm²/s and density equal to 1000 kg/m³. Curve tolerance according to ISO 9906.

PERFORMANCE AT 50 Hz

MODEL	ELECTRICAL DATA		HYDRAULIC DATA									
	P2 NOMINAL		Q=m³/h	0	5,4	6,0	7,2	8,4	9,6	10,8	12,0	14,4
	kW	HP	Q=l/min	0	90	100	120	140	160	180	200	240
S4 12/6	1,1	1,5	H (m)	30	29	28	25	24	23	21	18	11
S4 12/9	1,5	2		46	42	40	38	36	34	31	28	17
S4 12/13	2,2	3		66	61	59	55	52	49	44	38	23
S4 12/18	3	4		91	84	82	76	72	68	60	52	31
S4 12/24	4	5,5		122	112	110	101	96	91	81	70	46
S4 12/34	5,5	7,5		172	158	156	144	136	129	115	101	65
S4 12/44	7,5	10		215	192	188	175	165	156	140	124	81

ELECTRICAL DATA AND DIMENSIONS

MODEL	ELECTRICAL DATA					Ø mm	H mm	DNM	PACKING DIMENSIONS			VOLUME m³	WEIGHT kg
	MOTOR	POWER INPUT 50 Hz	P2 NOMINAL		In A				L/A	L/B	H		
			kW	HP									
S4 12/6	40L M	1 x 230 V ~	1,1	1,5	8,5	99	890	2"	120	120	990	0,014	14,2
	40L T	3 x 230 V ~	1,1	1,5	6,2	99	870	2"	120	120	970	0,014	13,2
	40L T	3 x 400 V ~	1,1	1,5	3,6	99	870	2"	120	120	970	0,014	13,2
	4GG M	1 x 230 V ~	1,1	1,5	8,6	99	867	2"	120	120	967	0,014	16,3
	4GG T	3 x 230 V ~	1,1	1,5	5,5	99	822	2"	120	120	922	0,013	14,1
	4GG T	3 x 400 V ~	1,1	1,5	3,2	99	822	2"	120	120	922	0,013	14,1
S4 12/9	40L M	1 x 230 V ~	1,5	2	10,8	99	1093	2"	120	120	1193	0,017	17,5
	40L T	3 x 230 V ~	1,5	2	7,9	99	1047	2"	120	120	1147	0,017	15,5
	40L T	3 x 400 V ~	1,5	2	4,6	99	1047	2"	120	120	1147	0,017	15,5
	4GG M	1 x 230 V ~	1,5	2	11	99	1086	2"	120	120	1186	0,017	19,8
	4GG T	3 x 230 V ~	1,5	2	7,6	99	1041	2"	120	120	1141	0,016	17,6
	4GG T	3 x 400 V ~	1,5	2	4,4	99	1041	2"	120	120	1141	0,016	17,6
S4 12/13	40L M	1 x 230 V ~	2,2	3	15	99	1378	2"	120	120	1478	0,021	21,5
	40L T	3 x 230 V ~	2,2	3	10,4	99	1358	2"	120	120	1458	0,021	20,4
	40L T	3 x 400 V ~	2,2	3	6	99	1358	2"	120	120	1458	0,021	20,4
	4GG M	1 x 230 V ~	2,2	3	15	99	1313	2"	120	120	1413	0,020	21,7
	4GG T	3 x 230 V ~	2,2	3	10,2	99	1293	2"	120	120	1393	0,020	21
	4GG T	3 x 400 V ~	2,2	3	5,9	99	1293	2"	120	120	1393	0,020	21
S4 12/18	40L T	3 x 230 V ~	3	4	13	99	1685	2"	120	120	1785	0,026	26,4
	40L T	3 x 400 V ~	3	4	7,5	99	1685	2"	120	120	1785	0,026	26,4
	4GG T	3 x 230 V ~	3	4	14,3	99	1711	2"	120	120	1811	0,026	31
	4GG T	3 x 400 V ~	3	4	8,3	99	1711	2"	120	120	1811	0,026	31
S4 12/24	40L T	3 x 230 V ~	4	5,5	16,6	99	2067	2"	120	120	2167	0,031	29,2
	40L T	3 x 400 V ~	4	5,5	9,6	99	2067	2"	120	120	2167	0,031	29,2
	4GG T	3 x 230 V ~	4	5,5	17,3	99	2093	2"	120	120	2193	0,032	35,9
	4GG T	3 x 400 V ~	4	5,5	10	99	2093	2"	120	120	2193	0,032	35,9
S4 12/34	40L T	3 x 230 V ~	5,5	7,5	22,6	99	2693	2"	280	230	2820	0,182	64,7
	40L T	3 x 400 V ~	5,5	7,5	13,1	99	2693	2"	280	230	2820	0,182	64,7
	4GG T	3 x 230 V ~	5,5	7,5	24,2	99	2719	2"	280	230	2820	0,182	67,9
	4GG T	3 x 400 V ~	5,5	7,5	14	99	2719	2"	280	230	2820	0,182	67,9
S4 12/44	40L T	3 x 230 V ~	7,5	10	29,2	99	3290	2"	280	230	3380	0,218	75,9
	40L T	3 x 400 V ~	7,5	10	16,9	99	3290	2"	280	230	3380	0,218	75,9
	4GG T	3 x 230 V ~	7,5	10	30,1	99	3316	2"	280	230	3380	0,218	78,8
	4GG T	3 x 400 V ~	7,5	10	17,4	99	3316	2"	280	230	3380	0,218	78,8

4GG: 4" encapsulated motor with stator immersed in thermosetting insulating resin.
40L: 4" rewindable oil-filled motor.

S4 12

4" SUBMERSIBLE ELECTRIC PUMPS

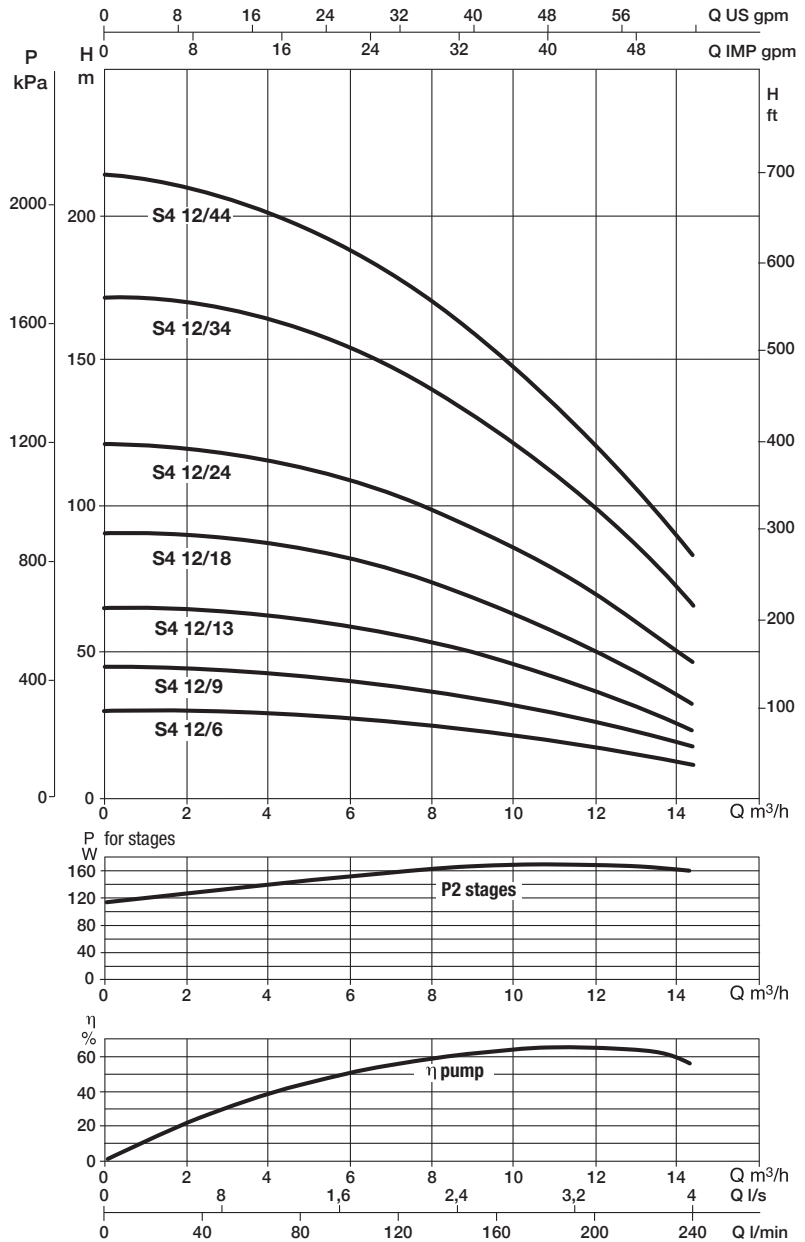
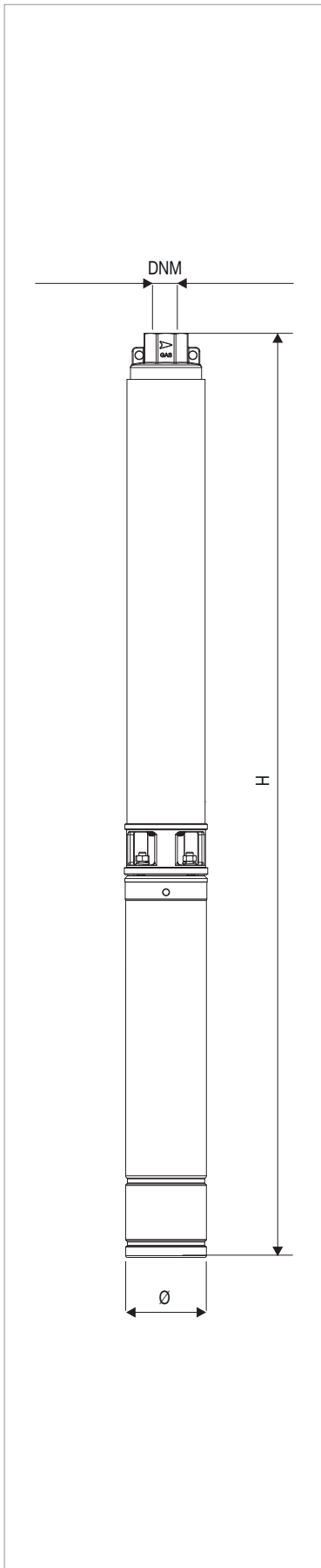

Performance at 50 Hz 2 poles. The performance curves are based on kinematic viscosity values = 1 mm²/s and density equal to 1000 kg/m³. Curve tolerance according to ISO 9906.

PERFORMANCE AT 50 Hz

MODEL	ELECTRICAL DATA		HYDRAULIC DATA								
	P2 NOMINAL		Q=m³/h	0	9,6	10,8	12,0	14,4	16,8	19,2	21,6
	kW	HP	Q=l/min	0	160	180	200	240	280	320	360
S4 16/8	1,5	2	H (m)	37	31	29	26	22	18	13	7
S4 16/12	2,2	3		55	46	43	39	33	27	19	10
S4 16/16	3	4		73	61	57	52	44	36	25	13
S4 16/21	4	5,5		96	81	75	68	58	47	33	18
S4 16/29	5,5	7,5		133	111	104	94	80	65	46	24
S4 16/38	7,5	10		174	146	136	124	105	86	60	32

ELECTRICAL DATA AND DIMENSIONS

MODEL	ELECTRICAL DATA					Ø mm	H mm	DNM	PACKING DIMENSIONS			VOLUME m³	WEIGHT kg
	MOTOR	POWER INPUT 50 Hz	P2 NOMINAL		In A				L/A	L/B	H		
			kW	HP									
S4 16/8	40L M	1 x 230 V ~	1,5	2	10,8	99	1167	2"	120	120	1267	0,018	17,7
	40L T	3 x 230 V ~	1,5	2	7,9	99	1121	2"	120	120	1221	0,018	15,7
	40L T	3 x 400 V ~	1,5	2	4,6	99	1121	2"	120	120	1221	0,018	15,7
	4GG M	1 x 230 V ~	1,5	2	11	99	1160	2"	120	120	1260	0,018	20
	4GG T	3 x 230 V ~	1,5	2	7,6	99	1115	2"	120	120	1215	0,017	17,8
	4GG T	3 x 400 V ~	1,5	2	4,4	99	1115	2"	120	120	1215	0,017	17,8
S4 16/12	40L M	1 x 230 V ~	2,2	3	15	99	1517	2"	120	120	1617	0,023	23
	40L T	3 x 230 V ~	2,2	3	10,4	99	1497	2"	120	120	1597	0,023	21,9
	40L T	3 x 400 V ~	2,2	3	6	99	1497	2"	120	120	1597	0,023	21,9
	4GG M	1 x 230 V ~	2,2	3	15	99	1452	2"	120	120	1552	0,022	23,2
	4GG T	3 x 230 V ~	2,2	3	10,2	99	1432	2"	120	120	1532	0,022	22,5
	4GG T	3 x 400 V ~	2,2	3	5,9	99	1432	2"	120	120	1532	0,022	22,5
S4 16/16	40L T	3 x 230 V ~	3	4	13	99	1841	2"	120	120	1941	0,028	27,4
	40L T	3 x 400 V ~	3	4	7,5	99	1841	2"	120	120	1941	0,028	27,4
	4GG T	3 x 230 V ~	3	4	14,3	99	1867	2"	120	120	1967	0,028	32
	4GG T	3 x 400 V ~	3	4	8,3	99	1867	2"	120	120	1967	0,028	32
S4 16/21	40L T	3 x 230 V ~	4	5,5	16,6	99	2250	2"	120	120	2350	0,034	31,8
	40L T	3 x 400 V ~	4	5,5	9,6	99	2250	2"	120	120	2350	0,034	31,8
	4GG T	3 x 230 V ~	4	5,5	17,3	99	2276	2"	120	120	2376	0,034	38,5
	4GG T	3 x 400 V ~	4	5,5	10	99	2276	2"	120	120	2376	0,034	38,5
S4 16/29	40L T	3 x 230 V ~	5,5	7,5	22,6	99	2903	2"	280	230	3080	0,198	67,9
	40L T	3 x 400 V ~	5,5	7,5	13,1	99	2903	2"	280	230	3080	0,198	67,9
	4GG T	3 x 230 V ~	5,5	7,5	24,2	99	2929	2"	280	230	3080	0,198	71,1
	4GG T	3 x 400 V ~	5,5	7,5	14	99	2929	2"	280	230	3080	0,198	71,1
S4 16/38	40L T	3 x 230 V ~	7,5	10	29,2	99	3554	2"	280	230	3780	0,243	82,9
	40L T	3 x 400 V ~	7,5	10	16,9	99	3554	2"	280	230	3780	0,243	82,9
	4GG T	3 x 230 V ~	7,5	10	30,1	99	3580	2"	280	230	3780	0,243	85,8
	4GG T	3 x 400 V ~	7,5	10	17,4	99	3580	2"	280	230	3780	0,243	85,8

4GG: 4" encapsulated motor with stator immersed in thermosetting insulating resin.

40L: 4" rewindable oil-filled motor.

S4 16

4" SUBMERSIBLE ELECTRIC PUMPS

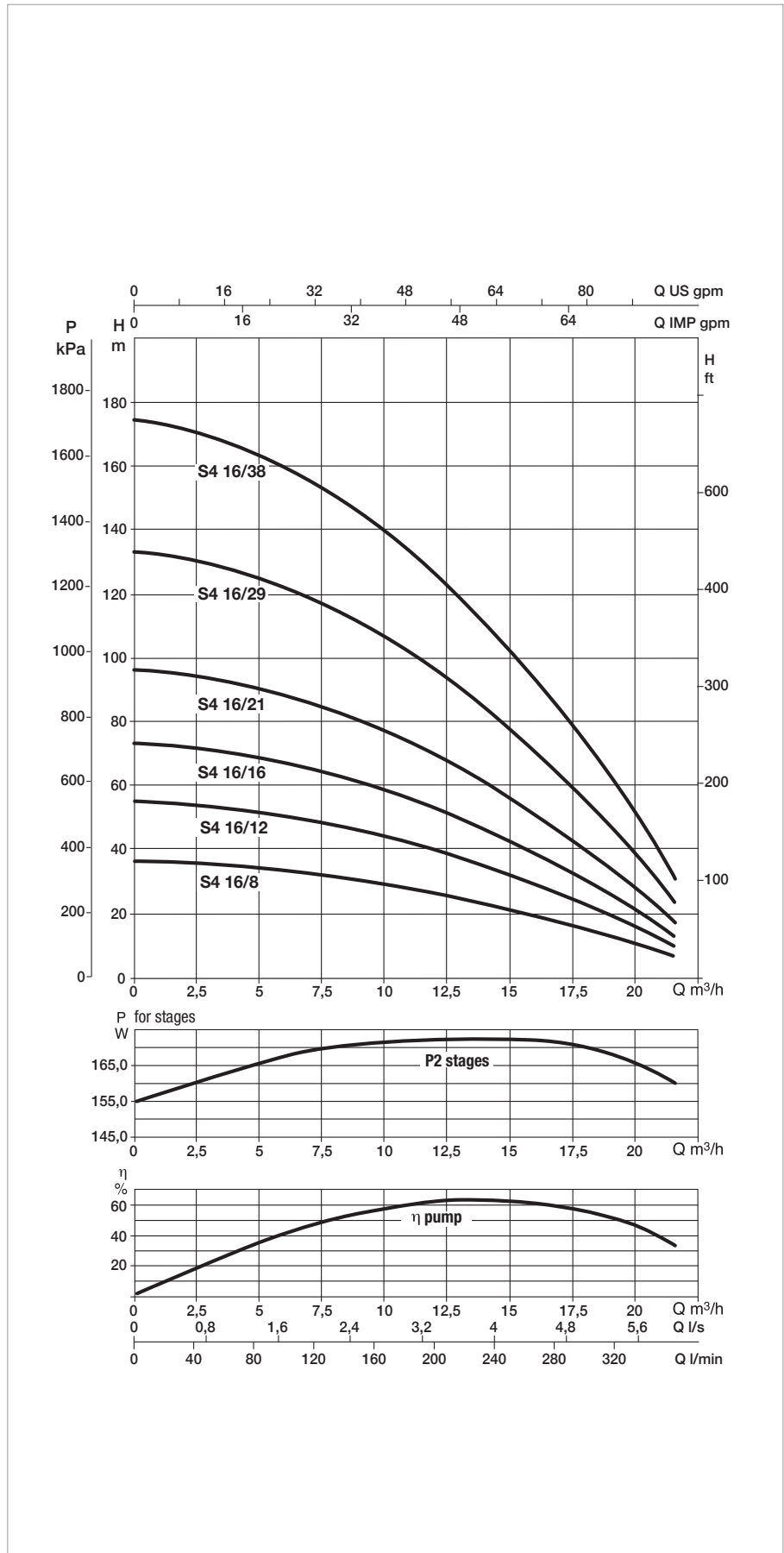
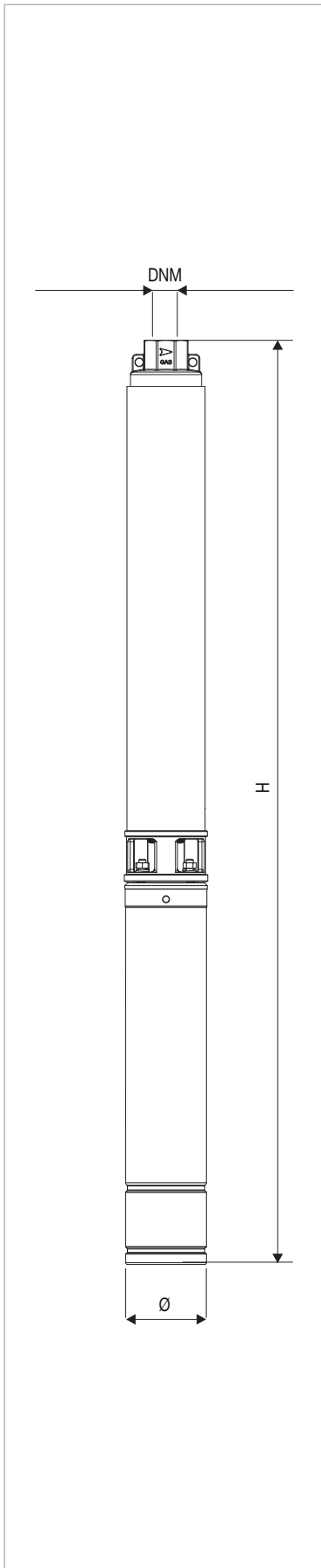

Performance at 50 Hz 2 poles. The performance curves are based on kinematic viscosity values = 1 mm²/s and density equal to 1000 kg/m³. Curve tolerance according to ISO 9906.



MAKING WATER EASY

Via Marco Polo, 14 - 35035 Mestrino (PD) Italy - Tel. +39.049.5125000 - Fax +39.049.5125950

www.dabpumps.com

DAB
PUMPS SELECTOR



On-line product selection



DAB PUMPS LTD.
Unit 6 Gilberd Court
Newcomen Way, Severalls Park
CO4 9WN
Colchester
ordersuk@dwtgroup.com
Tel. +44 0333 777 5010



DAB PUMPS IBERICA S.L.
Calle Verano 18-20-22
28850 - Torrejón de Ardoz - Madrid
Spain
Info.spain@dwtgroup.com
Tel. +34 91 6569545



DAB PUMPS DE MÉXICO, S.A. DE C.V.
Av Amsterdam 101 Local 4
Col. Hipódromo Condesa,
Del. Cuauhtémoc CP 06170
Ciudad de México
Tel. +52 55 553 2621



DAB PUMPS BV
'tHofveld 6 C1
1702 Groot Bijgaarden - Belgium
info.belgium@dwtgroup.com
Tel. +32 2 4668353



DAB PUMPS HUNGARY KFT.
H-8800
Nagykanizsa, Buda Ernő u.5
Hungary
Tel. +36 93501700



DAB PUMPS SOUTH AFRICA (PTY) LTD
Twenty One industrial Estate,
16 Purlin Street, Unit B, Warehouse 4
Olifantsfontein -1667 - South Africa
info.sa@dwtgroup.com
Tel. +27 12 361 3997



DAB PUMPS B.V.
Statenlaan, 4
5223 LA, 's-Hertogenbosch
Nederland
info.nl@dabpumps.com
Tel. +31 416 387280



DAB PUMPS POLAND Sp. z o.o.
Ul. Cieslewskich 35K
03-017 Warszawa - Poland
sprzedaz@dabpumps.com.pl



DAB PUMPS (QINGDAO) CO. LTD.
No.10 Xindong Road
Jiulong Town,
Jiaozhou City
266319 Qingdao (Shandong) - China
sales.cn@dwtgroup.com
Tel. +86 400 186 8280



DAB PUMPS FRANCE SAS
Tour Ariane, Paris la Défense 9
5, Place de la Pyramide
92800 Puteaux - France
info.fr@dabpumps.com
Tel. +33 (0)6 79 63 05 46
+33 (0)7 89 01 53 35



DAB PUMPS INC.
3226 Benchmark Drive
Ladson, SC 29456 - USA
info.usa@dwtgroup.com
Tel. 1- 843-797-5002
Fax 1-843-797-3366



DAB PUMPS OCEANIA PTY LTD
426 South Gippsland Highway,
Dandenong South VIC 3175 - Australia
info.oceania@dwtgroup.com
Tel. +61 1300 378 677



DAB PUMPS GMBH
Am Nordpark 3
D - 41069 Mönchengladbach - Germany
info.germany@dwtgroup.com
Tel. +49 2161 47388-0
Fax +49 2161 47388-36



DAB PUMPS CANADA INC.
333 Bay Street, Suite 4600, Toronto,
Ontario, M5H 2S5, - Canada
orders@dwtgroup.ca
Tel. 1-833-322-7867



PT DAB PUMPS INDONESIA
Satrio Tower lantai 26
unit C-D, Jl. Prof. Dr. Satrio Kav. C4,
Kel. Kuningan Timur, Kec. Setiabudi, Kota Adm.
Jakarta Selatan, Prov. DKI Jakarta. - Indonesia
Tel. +62 2129222850