

DIVERTRON

THE SHAPE OF
EFFICIENCY



DAB[®]
MAKING WATER EASY

DIVERTRON

THE SHAPE OF EFFICIENCY

At DAB we listen to the needs of customers, technicians, the market and the environment. That is why we always anticipate the evolution of our products, improving their characteristics, potential and usability before all else and before it's too late.

The first generation of Divertron was developed in **2007**, breaking into the market **as a complete novelty**: it is a range of submersible pumps **with integrated on/off electronics**, a feature that has made it a product of excellence to this day.

DAB's ongoing research and drive for continuous development has led it to launch **the second generation of Divertron**. This product has been improved in terms of appearance and technical and technological content in order **to increase its performance and reduce its consumption**, adapting it well in advance to the next MEI regulations on **energy efficiency**. At the same time, it has been made **even stronger and easier to install and maintain**.

Find out more 



**A RENEWED PRODUCT:
MORE POWERFUL AND EASIER TO USE IN ALL ITS APPLICATIONS**

📍 tank installation



STANDARD VERSION



FLOAT

By detecting the water level, the float prevents repeat starting routines and provides additional protection against dry running. In addition, the float also prevents the pump from becoming blocked due to a continuous lack of water.



Divertron is a submersible pump with integrated on/off electronics for domestic water supply. Ideal for irrigation and gardening and for the reuse of rainwater, it can be installed inside collecting tanks, wells and tanks with a maximum immersion depth of 12 metres.

KIT X. Filter and ball float

Attached to the special filter designed for Version X, this accessory prevents water from being sucked up from the very bottom of a well or tank, so that sludge, dust or debris is not drawn in. The kit is ready for use because the connecting tube is already included.



📍 well installation

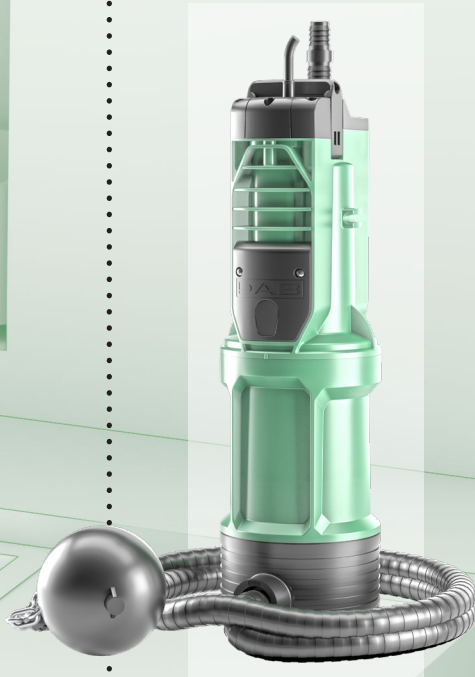

X VERSION



WATER BOOSTING

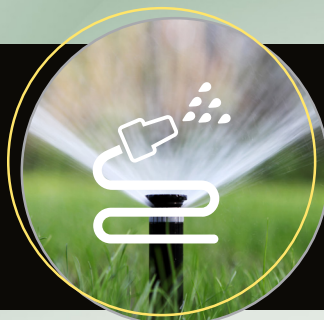

GARDENING & IRRIGATION



RAIN WATER REUSE

DIVERTRON

THE SECOND GENERATION

LESS CONSUMPTION, MORE OUTPUT

Combining the new high-efficiency impellers and an optimised mechanical seal, **the new Divertron consumes 30% less power than the current model, while still achieving higher performance.**

In line with the MEI directives on energy efficiency, which will enter into force in 2024, **it helps to respect the environment and reduce energy bills.** This is a real benefit your customers will want to hear about.

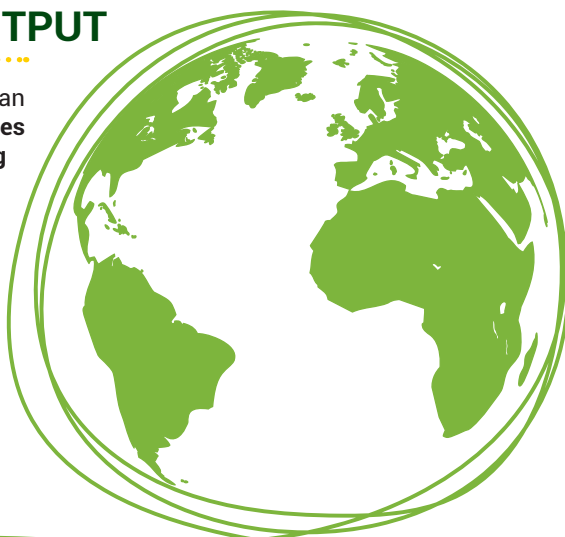

CONTINUITY OF OPERATION AND DURABILITY OVER TIME

In this new version, **the float works in conjunction with the integrated electronic card to offer double protection against dry running**, preventing the repetition of starting routines. This ensures superior and smooth operation and less stress on the pump, **extending its life cycle and reducing the need for special maintenance.** A real long-term investment.



SIMPLE MAINTENANCE

The condenser can be accessed **directly** from outside in a quick and easy way, **and removed without complicated disassembly operations.** Fast and functional.

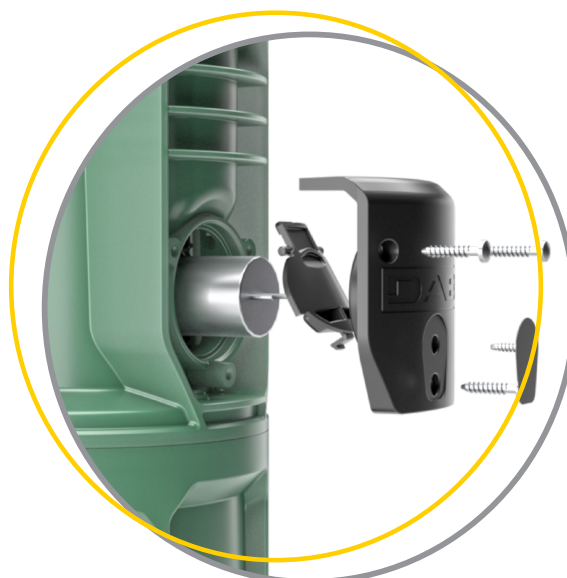

OVERVIEW

PRACTICAL TO USE

The new **retractable handle** makes it easier to move the pump, while **the hook** is designed to use a cord when the pump is lowered into a tank or well.

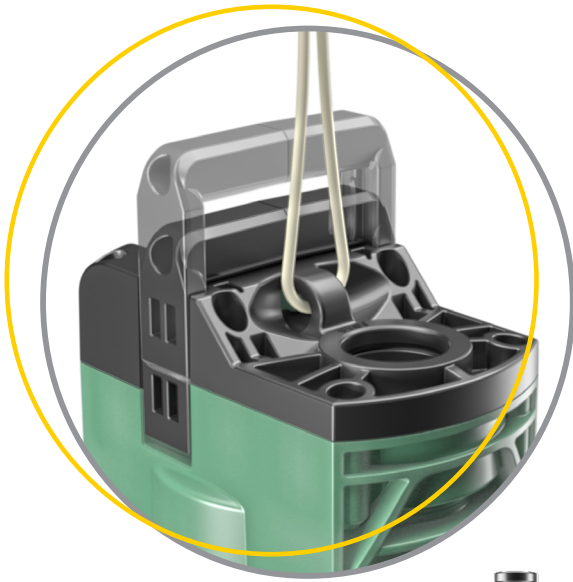

DIVERTRON

FEATURES

HIGH EFFICIENCY IMPELLERS

The technopolymer impellers are based on in-depth research into fluid dynamics to increase performance: higher efficiency with lower energy consumption.

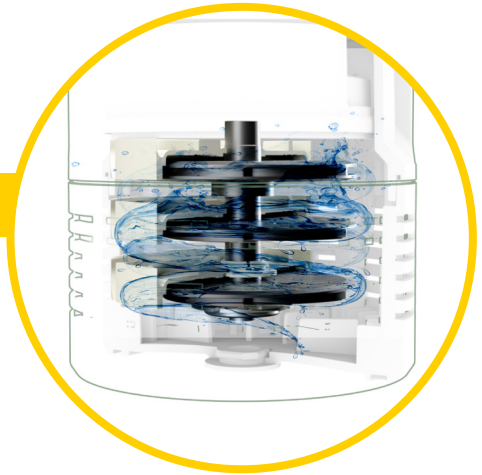

NEW MOTOR

The motor has been redesigned to reduce consumption. But also to improve performance.

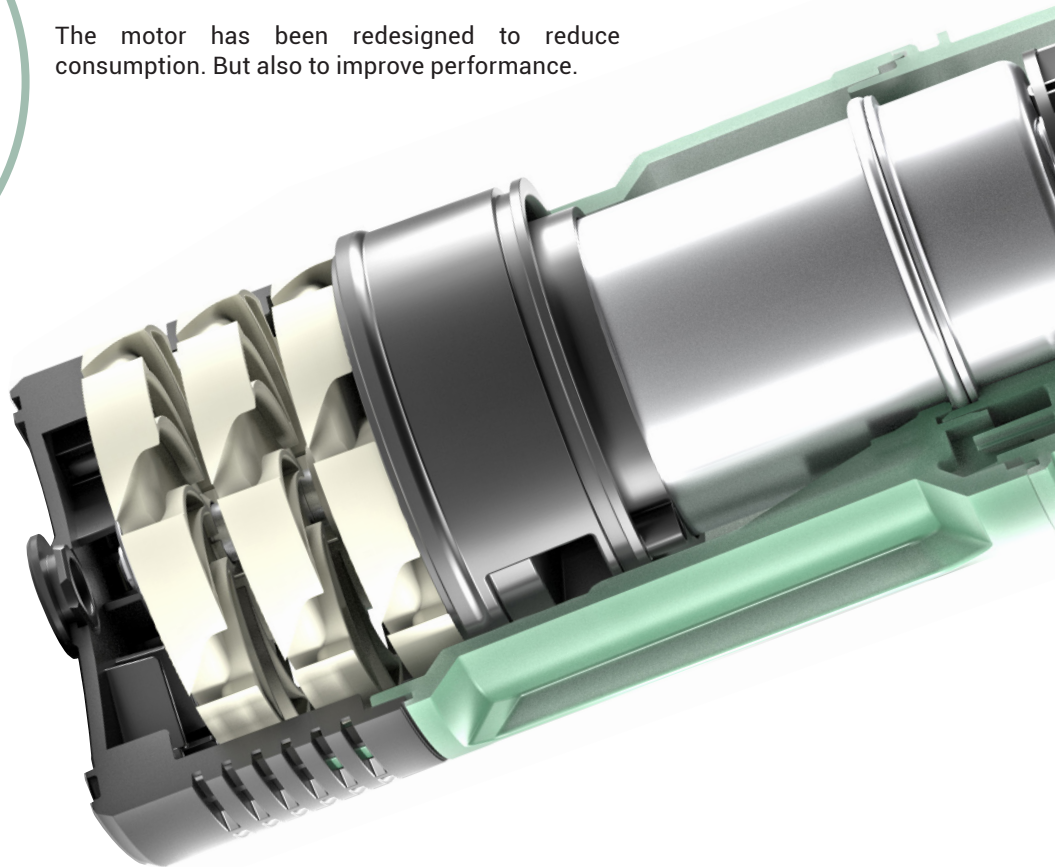

MECHANICAL SEAL

We have applied a mechanical sealing system that offers two advantages: greater strength and durability, but also greater efficiency, thanks to the combined action with the new hydraulics.



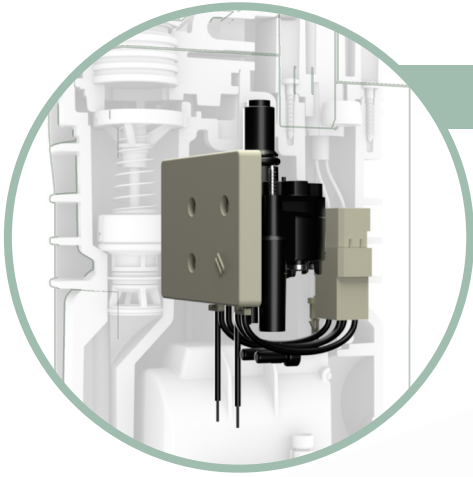

INTEGRATED ON/OFF ELECTRONICS

The integrated electronic card manages starting and stopping of the pump automatically in relation to the water demand, without the need to install an external controller. This prevents dry running of the pump in the event of a prolonged shortage of water. Easier to install, and easier and safer to use.

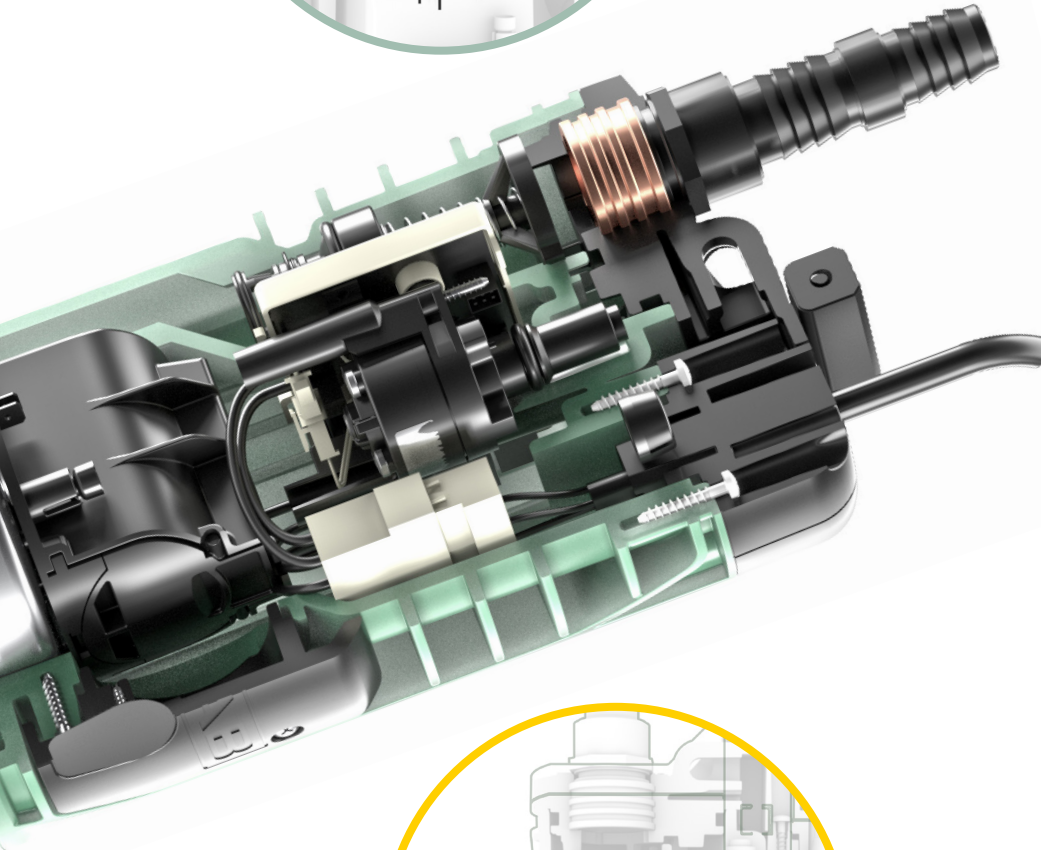

NON-RETURN VALVE

The non-return valve ensures quick and safe initial installation, allowing immediate priming.

DIRECT ACCESS TO THE CAPACITOR

The capacitor housing is designed to be replaced quickly without the need to remove the pump housing.



DIVERTRON

SELECTION TABLE



DIVERTRON
650



DIVERTRON
900

MAXIMUM NUMBER OF FLOORS	WATER PRESSURIZATION / RAIN WATER REUSE			IRRIGATION
	SMALL APARTMENT with 1 bathroom (6 taps)	MEDIUM APARTMENT with 2 bathrooms (10 taps)	LARGE APARTMENT with 2 bathrooms + garden (15 taps)	STATIC SPRINKLERS RANGE 4 m Flow rate: = 6 l/min Operating pressure: 2.4 bar
	MAXIMUM NUMBER OF APARTMENTS			MAXIMUM NUMBER OF SPRINKLERS
DIVERTRON 650	1	3	1	9
	2	2	1	
	3	1	0	
DIVERTRON 900	1	3	1	10
	2	2	1	
	3	2	1	
	4	1	0	

* The table is indicative and based on average values. To ensure optimal sizing, perform a careful assessment of the specific system.

VERSIONS *



STANDARD VERSION



WITH FLOAT



X VERSION



Kit X for X Version



* Recommended installation with auxiliary tank

TECHNICAL DATA

MAXIMUM FLOW RATE	up to 6 m ³ /h
MAXIMUM HEAD	up to 45 m
P1	up to 920 W
P2 NOMINAL	up to 0,56 Kw (0,75HP)
MAXIMUM IMMERSION DEPTH	12 m
MAX AMBIENT AND LIQUID TEMPERATURE:	+40 °C
FACTORY CUT-IN:	2,4 bar (±0,2)
DELIVERY THREAD:	1"
PUMP MAXIMUM DIAMETER:	160 mm.
DIMENSIONS:	Divertron 650: 487x160 mm Divertron 900: 534x160 mm

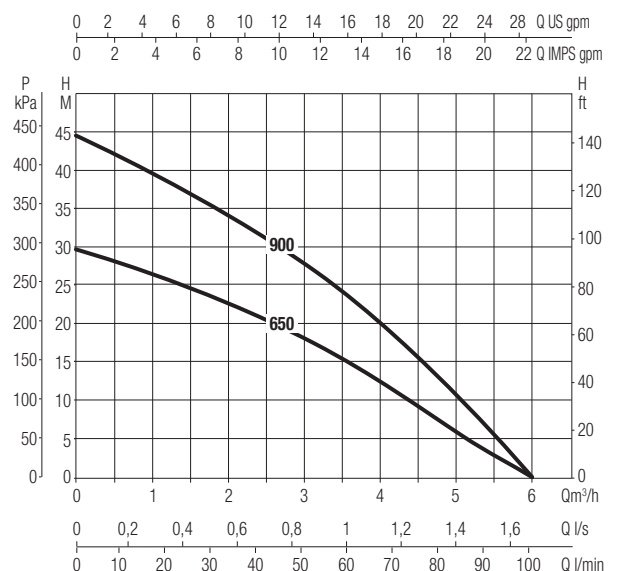



DAB PUMPS LTD.
Unit 6 Gilberd Court
Newcomen Way, Severalls Park
CO4 9WN
Colchester
ordersuk@dwtgroup.com
Tel. +44 0333 777 5010



DAB PUMPS IBERICA S.L.
Calle Verano 18-20-22
28850 - Torrejón de Ardoz - Madrid
Spain
Info.spain@dwtgroup.com
Tel. +34 91 6569545



DAB PUMPS DE MÉXICO, S.A. DE C.V.
Av Amsterdam 101 Local 4
Col. Hipódromo Condesa,
Del. Cuauhtémoc CP 06170
Ciudad de México
Tel. +52 55 553 2621



DAB PUMPS BV
'tHofveld 6 C1
1702 Groot Bijgaarden - Belgium
info.belgium@dwtgroup.com
Tel. +32 2 4668353



DAB PUMPS HUNGARY KFT.
H-8800
Nagykanizsa, Buda Ernő u.5
Hungary
Tel. +36 93501700



DAB PUMPS SOUTH AFRICA (PTY) LTD
Twenty One industrial Estate,
16 Purlin Street, Unit B, Warehouse 4
Olifantsfontein -1667 - South Africa
info.sa@dwtgroup.com
Tel. +27 12 361 3997



DAB PUMPS B.V.
Statenlaan, 4
5223 LA, 's-Hertogenbosch
Nederland
info.nl@dabpumps.com
Tel. +31 416 387280



DAB PUMPS POLAND Sp. z o.o.
Ul. Cieslewskich 35K
03-017 Warszawa - Poland
sprzedaz@dabpumps.com.pl



DAB PUMPS (QINGDAO) CO. LTD.
No.10 Xindong Road
Jiulong Town,
Jiaozhou City
266319 Qingdao (Shandong) - China
sales.cn@dwtgroup.com
Tel. +86 400 186 8280



DAB PUMPS FRANCE SAS
Tour Ariane, Paris la Défense 9
5, Place de la Pyramide
92800 Puteaux - France
info.fr@dabpumps.com
Tel. +33 (0)6 79 63 05 46
+33 (0)7 89 01 53 35



DAB PUMPS INC.
3226 Benchmark Drive
Ladson, SC 29456 - USA
info.usa@dwtgroup.com
Tel. 1-843-797-5002
Fax 1-843-797-3366



DAB PUMPS OCEANIA PTY LTD
426 South Gippsland Highway,
Dandenong South VIC 3175 - Australia
info.oceania@dwtgroup.com
Tel. +61 1300 378 677



DAB PUMPS GMBH
Am Nordpark 3
D - 41069 Mönchengladbach - Germany
info.germany@dwtgroup.com
Tel. +49 2161 47388-0
Fax +49 2161 47388-36



DAB PUMPS CANADA INC.
333 Bay Street, Suite 4600, Toronto,
Ontario, M5H 2S5, - Canada
orders@dwtgroup.ca
Tel. 1-833-322-7867



PT DAB PUMPS INDONESIA
Satrio Tower lantai 26
unit C-D, Jl. Prof. Dr. Satrio Kav. C4,
Kel. Kuningan Timur, Kec. Setiabudi, Kota Adm.
Jakarta Selatan, Prov. DKI Jakarta. - Indonesia
Tel. +62 2129222850