

DIVERTRON

SUBMERSIBLE MULTI-IMPELLER ELECTRONIC PUMPS





TECHNICAL DATA

Operating range: 1 m³/h to 5.4 m³/h

Head up to: 45 m (model 900) and 30 m (model 650).

Maximum immersion depth: 12 m

Pumped liquid: Clean, free of solids or abrasive substances, non-viscous, non-aggressive, non-crystallised and chemically neutral.

Liquid temperature range:

0°C to +35°C for domestic use (EN 60335-2-41).

Maximum suction depth: 15 metres.

Flanges, thread: 1" (supplied as standard with a four-section reducer fitting)

Maximum pump diameter: 160 mm.

Impeller construction material: technopolymer

Pump protection degree: IP 68.

Insulation class: F.

Single-phase power supply: 230 V 50 Hz

Three-phase power supply: not available

Power cable (m) and plug: 15 m H07RNF with plug

Installation: Fixed or portable in vertical position only.

Special designs on request: Different cable lengths, different plugs.

Multi-impeller submersible pump with integrated electronic for automatic switching on and off. There are versions with two or three impellers available. The pump is designed for pressurization, gardening and irrigation in residential building service.

CONSTRUCTION FEATURES OF THE PUMP

Pump body and impellers in technopolymer to resist corrosion and oxidation. The delivery has an integrated non-return valve. There are version with anti-debris filter in technopolymer or fitting with brass insert for use with float suction kit (the X version). Version with float available.

CONSTRUCTION FEATURES OF THE MOTOR

Asynchronous motor. Motor shaft in stainless steel AISI 416 + AISI 304. Integrated starting capacitor and thermal protection against overheating of the motor.

FEATURES OF THE ELECTRONIC

The electronics allow automatic switching on and off. The pressure switch and the flow sensor are integrated. Dry running protection. Quick access to the capacitor compartment.

DIVERTRON

SUBMERSIBLE MULTI-IMPELLER ELECTRONIC PUMPS

MATERIALS

N°	PARTS	MATERIALS
1	BASE	TECHNOPOLYMER
2	INSPECTION CAP	EPDM
3	NUT	SS A2
4	WASHER	SS A2
5	FIRST STAGE CASE	TECHNOPOLYMER
6	FRONT FLOATING RING	TECHNOPOLYMER
7	DIFFUSER	TECHNOPOLYMER
8	BACK FLOATING RING	TECHNOPOLYMER
9	STAGE CASE	TECHNOPOLYMER
10	IMPELLER	TECHNOPOLYMER/SS AISI 304
11	SHAFT	SS AISI 303
12	FINAL DIFFUSER CAP	TECHNOPOLYMER
13	MOTOR FLANGE	TECHNOPOLYMER
14	MECHANICAL SEAL	CARBON-IMPREGNATED RESIN/CERAMIC/NBR
15	OR GASKET	EPDM
16	OR GASKET	EPDM
17	MOTOR	
	CAP	SS AISI 304
	MOTOR SHAFT	SS AISI 416
18	BODY	TECHNOPOLYMER
19	OR GASKET	EPDM
20	COVER	TECHNOPOLYMER
21	NON-RETURN VALVE	TECHNOPOLYMER/NBR/AISI 302/AISI A2/FERRITE
22	PRESSURE SWITCH	TECHNOPOLYMER/SILICONE
23	SAND FILTER	TECHNOPOLYMER
24	OR GASKET	EPDM
25	OUTLET COVER	TECHNOPOLYMER
26	INSERT	BRASS
27	CAPACITOR COMPARTMENT COVER	TECHNOPOLYMER
28	CABLE FLANGE	TECHNOPOLYMER
29	HANDLE	TECHNOPOLYMER

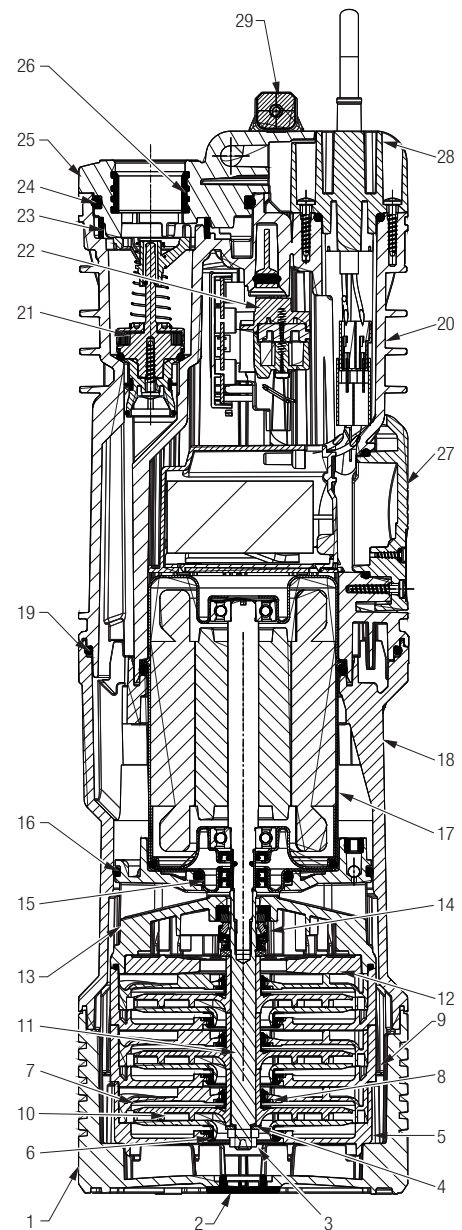

PERFORMANCE AT 50 HZ

MODEL	HYDRAULIC DATA								
	Q=m³/h	0	1,2	1,8	2,4	3,0	3,6	4,2	4,8
	Q=l/min	0	20	30	40	50	60	70	80
DIVERTRON 900	H (m)	45,8	42,1	39,4	35,6	31,1	25,2	18,8	11,9
DIVERTRON 650		30,4	27,7	25,8	23	19,7	15,2	10,3	4,8
DIVERTRON X 900		45,8	42,1	39,4	35,6	31,1	25,2	18,8	11,9
DIVERTRON X 650		30,4	27,7	25,8	23	19,7	15,2	10,3	4,8

ELECTRICAL DATA AND DIMENSIONS

MODEL	ELECTRICAL DATA							CAPACITOR									PACKING VOLUME dm ³	Q.TY X PALLET	WEIGHT Kg	
	POWER INPUT 50 Hz	P1 kW	P2 NOMINAL		I _n A	CAPACITOR		A	B	C	H	H1	H2	H3	PACKING DIMENSIONS					
			kW	HP		μF	V								L/A	L/B				H
DIVERTRON 900	1 x 220-240 V ~	0,92	0,56	0,75	4,2	12,5	450	Ø 160	-	-	536	517	503	596	550	195	250	28,6	32	11
DIVERTRON 650	1 x 220-240 V ~	0,63	0,42	0,56	2,9	8	450	Ø 160	-	-	488	469	455	548	550	195	250	28,6	32	9,5
DIVERTRON X 900	1 x 220-240 V ~	0,92	0,56	0,75	4,2	12,5	450	Ø 160	186	33	536	517	503	596	550	195	250	28,6	32	11
DIVERTRON X 650	1 x 220-240 V ~	0,63	0,42	0,56	2,9	8	450	Ø 160	186	33	488	469	455	548	550	195	250	28,6	32	9,5

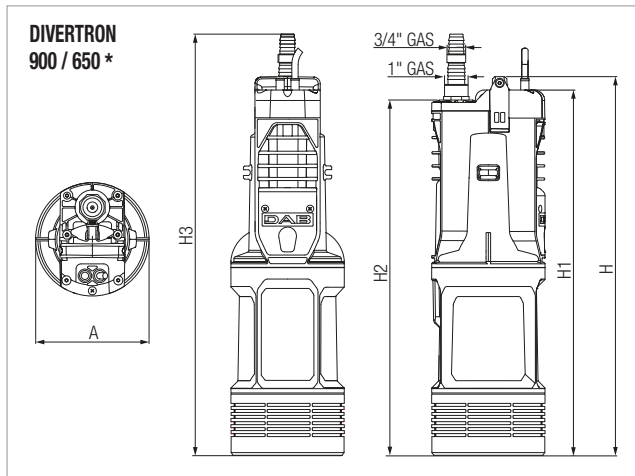

* Same dimensions for models 900 A - 650 A (with float switch)

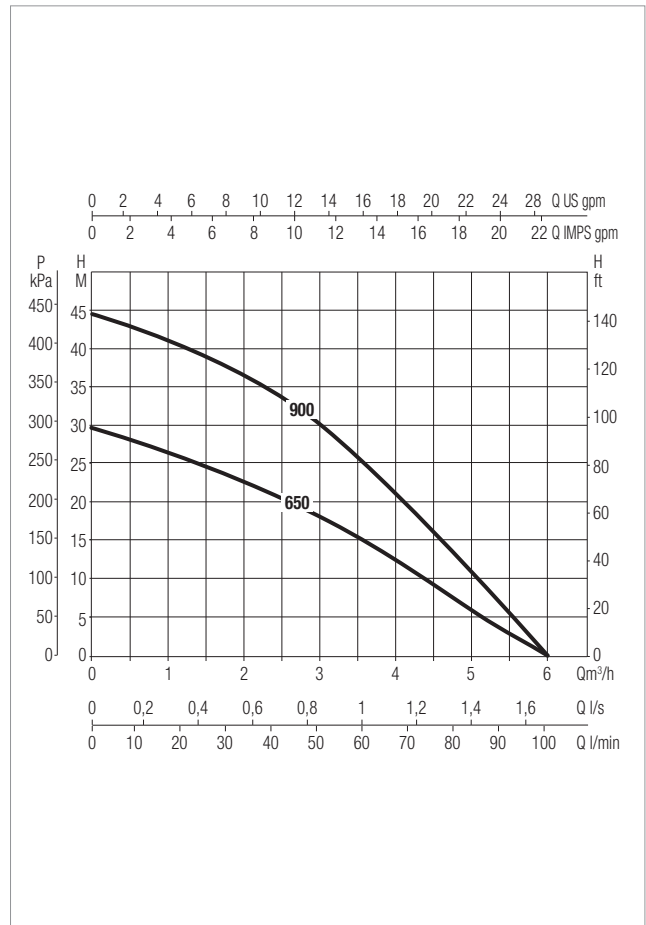
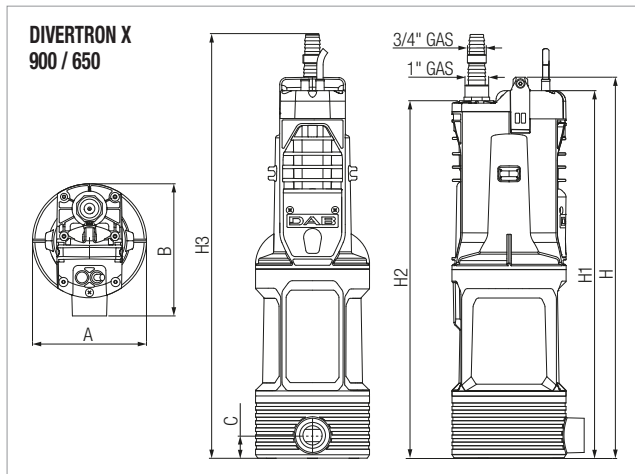

The performance curves are based on kinematic viscosity values = 1 mm²/s and density equivalent to 1000 kg/m³. Curve tolerance according to ISO 9906.

ACCESSORIES

DIVERTRON

	DESCRIPTION	PACKING DIMENSIONS			WEIGHT Kg
		L/A	L/B	H	
	<p>SUCTION KIT FOR DIVERTRON X</p> <p>Combined to X version can be used to collect water at such a level as to avoid the pumping of dust and mud found at the bottom of wells and tanks.</p>	320	190	245	1,1

DAB

PUMPS SELECTOR

On-line selection tool



DAB PUMPS LTD.
Unit 6 Gilberd Court
Newcomen Way, Severalls Park
CO4 9WN
Colchester
ordersuk@dwtgroup.com
Tel. +44 0333 777 5010



DAB PUMPS IBERICA S.L.
Calle Verano 18-20-22
28850 - Torrejón de Ardoz - Madrid
Spain
Info.spain@dwtgroup.com
Tel. +34 91 6569545



DAB PUMPS DE MÉXICO, S.A. DE C.V.
Av Amsterdam 101 Local 4
Col. Hipódromo Condesa,
Del. Cuauhtémoc CP 06170
Ciudad de México
Tel. +52 55 553 2621



DAB PUMPS BV
'tHofveld 6 C1
1702 Groot Bijgaarden - Belgium
info.belgium@dwtgroup.com
Tel. +32 2 4668353



DAB PUMPS HUNGARY KFT.
H-8800
Nagykanizsa, Buda Ernő u.5
Hungary
Tel. +36 93501700



DAB PUMPS SOUTH AFRICA (PTY) LTD
Twenty One industrial Estate,
16 Purlin Street, Unit B, Warehouse 4
Olifantsfontein -1667 - South Africa
info.sa@dwtgroup.com
Tel. +27 12 361 3997



DAB PUMPS B.V.
Statenlaan, 4
5223 LA, 's-Hertogenbosch
Nederland
info.nl@dabpumps.com
Tel. +31 416 387280



DAB PUMPS POLAND Sp. z o.o.
Ul. Cieslewskich 35K
03-017 Warszawa - Poland
sprzedaz@dabpumps.com.pl



DAB PUMPS (QINGDAO) CO. LTD.
No.10 Xindong Road
Jiulong Town,
Jiaozhou City
266319 Qingdao (Shandong) - China
sales.cn@dwtgroup.com
Tel. +86 400 186 8280



DAB PUMPS FRANCE SAS
Tour Ariane, Paris la Défense 9
5, Place de la Pyramide
92800 Puteaux - France
info.fr@dabpumps.com
Tel. +33 (0)6 79 63 05 46
+33 (0)7 89 01 53 35



DAB PUMPS INC.
3226 Benchmark Drive
Ladson, SC 29456 - USA
info.usa@dwtgroup.com
Tel. 1- 843-797-5002
Fax 1-843-797-3366



DAB PUMPS OCEANIA PTY LTD
426 South Gippsland Highway,
Dandenong South VIC 3175 - Australia
info.oceania@dwtgroup.com
Tel. +61 1300 378 677



DAB PUMPS GMBH
Am Nordpark 3
D - 41069 Mönchengladbach - Germany
info.germany@dwtgroup.com
Tel. +49 2161 47388-0
Fax +49 2161 47388-36



DAB PUMPS CANADA INC.
333 Bay Street, Suite 4600, Toronto,
Ontario, M5H 2S5, - Canada
orders@dwtgroup.ca
Tel. 1-833-322-7867



PT DAB PUMPS INDONESIA
Satrio Tower lantai 26
unit C-D, Jl. Prof. Dr. Satrio Kav. C4,
Kel. Kuningan Timur, Kec. Setiabudi, Kota Adm.
Jakarta Selatan, Prov. DKI Jakarta. - Indonesia
Tel. +62 2129222850