

SS

SUBMERSIBLE PUMPS 6", 7", 8", 10"





SS6A

TECHNICAL DATA

Flow rate maximum: up to 75 m³/h

Head up to: 670 m

Maximum immersion depth: depending on the motor

Type of pumped liquid: clean, free from solid or abrasive substances, non-viscous, non-aggressive, non-crystallized and chemically neutral. The version in AISI 316 stainless steel is also suitable for aggressive solutions and/or salt water

Maximum sand quantity: 50 g/m³

Liquid temperature range: from 0°C to +50°C (depending on the motor)

Maximum ambient temperature: 30°C (50°C available on request).

Flanges, thread:

SS6A and SS6B: 2 1/2"

SS6C: 3"

SS6D, SS6E: 4"

Pump maximum diameter: 132mm (167 mm for the version with high number of impeller)

Impeller/s material: pressed AISI 304 stainless steel

Maximum number of starts: depending on the motor

Protection class: IP 68

Single phase power input: 230 V 50 Hz up to 10 HP (4" version)

Three phase power input: 3x230 V 50 Hz / 3x400 V 50 Hz

Power cable (m) and plug: depending on the motor (all the motor are without the power plug)

Possible type of installation: fixed in vertical position. Horizontal installation permitted by removing the non-return valve and installing a cooling jacket (check the applicability of the motor for horizontal use in the dedicated section)

Special versions on request: molded AISI 316 stainless steel construction (impellers and pump body) for aggressive water applications, delivery ports with NPT standard

6" semi axial multi-impeller submersible pump in molded AISI 304 or AISI 316 stainless steel, designed for pressurization, lifting water from underground, gardening and irrigation in commercial building service and irrigation also in agriculture.

CONSTRUCTION FEATURES OF THE PUMP

Diffusers, impellers, supports, delivery and suction made entirely of pressed AISI 304 stainless steel or AISI 316. Impellers balanced and keyed to the shaft with a conical coupling, specially developed to guarantee: easy assembly, avoid malfunctions due to vibrations during rotation and reduce operating noise. Shaft driven by water lubricated bearings. The diffuser geometry facilitates the expulsion of sand particles with the pumped liquid and limits the infiltration of water between the stage. Integrated non-return valve to reduce localized pressure drops. Stainless steel filter applied to the suction mouth to prevent the entry of dissolved solid bodies. Delivery port threaded according to the GAS standard. Different types of impeller are available to guarantee the best efficiency at different flow rates and models up to 60 impellers to cover a wide range of heads.

CONSTRUCTION FEATURES OF THE MOTOR

Coupling with 4" or 8" motors depending on the power required by the hydraulic system:

- 4GG: 4" submersible encapsulated motor
- 40L: 4" submersible oil-bath motor
- 6GF: 6" submersible encapsulated motor
- TR6: 6" submersible rewindable motor
- TR8: 8" submersible rewindable motor

For operation with the variable frequency drive, refer to the specifications of the coupled motor.

For hydraulic systems in AISI 316 stainless steel, we recommend coupling with motors made of AISI 316 or DUPLEX stainless steel (check availability of the selected model).

PERFORMANCE RANGE - 2 POLES

The performance curves are based on the kinematic viscosity values = 1 mm²/s and density equal to 1000 kg/m³. Curve tolerance according to ISO 9906.

GRAPHIC SELECTION TABLE

50 Hz - 2900 r.p.m.

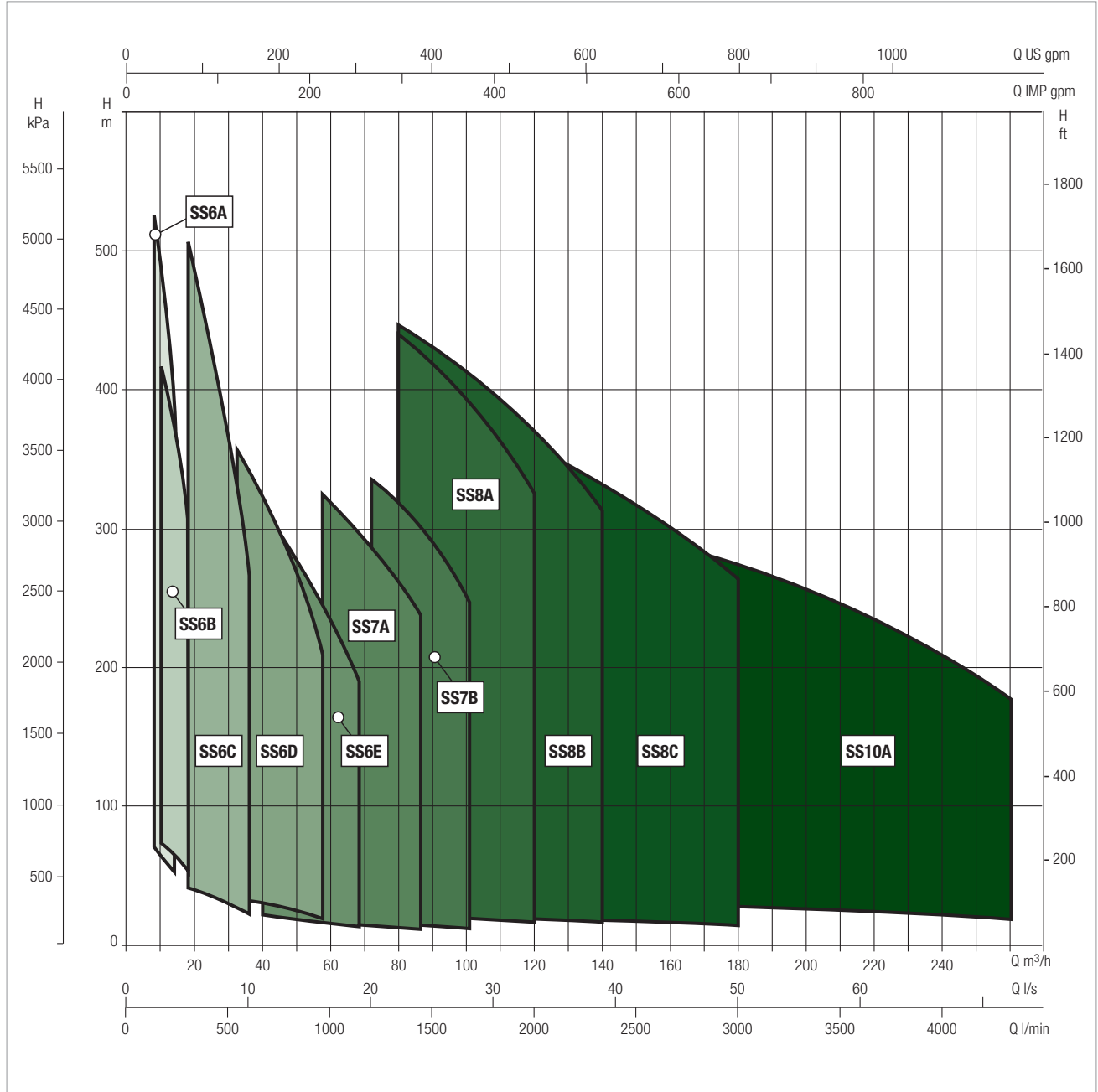

MATERIALS

N.	PARTS	STD version MATERIALS	AISI316 version MATERIALS
1	SUCTION CASE	STAINLESS STEEL (AISI 304L)	STAINLESS STEEL (AISI 316L)
2	SUCTION FILTER	STAINLESS STEEL (AISI 304L)	STAINLESS STEEL (AISI 316L)
3	SUCTION CASE WEAR RING	BRONZE (ASTM B145-4A)	POM
4	PUMP SHAFT	STAINLESS STEEL (AISI 420)	STAINLESS STEEL (AISI 316)
5	COLLET	STAINLESS STEEL (AISI 304)	STAINLESS STEEL (AISI 316)
6	IMPELLER WEAR RING	STAINLESS STEEL (AISI 304)	STAINLESS STEEL (AISI 316)
7	IMPELLER	STAINLESS STEEL (AISI 304L)	STAINLESS STEEL (AISI 316L)
8	DIFFUSER	STAINLESS STEEL (AISI 304L)	STAINLESS STEEL (AISI 316L)
9	INTERMEDIATE BEARING	RUBBER	POM
10	DIFFUSER WEAR RING	RUBBER	POM
11	NUT FOR STOP RING	STAINLESS STEEL (AISI 304L)	STAINLESS STEEL (AISI 316)
12	BEARING	RUBBER	STAINLESS STEEL (AISI 316L)
13	SHAFT STOPPER	BRONZE (ASTM B145-4A)	POM
14	VALVE	STAINLESS STEEL (AISI 304)	STAINLESS STEEL (AISI 316)
15	DISCHARGE CASE	STAINLESS STEEL (AISI 304)	STAINLESS STEEL (AISI 316)
16	TIE ROD	STAINLESS STEEL (AISI 304L)	STAINLESS STEEL (AISI 316L)
17	CABLE GUARD	STAINLESS STEEL (AISI 304)	STAINLESS STEEL (AISI 316)
18	TIE ROD NUT	STAINLESS STEEL (AISI 303)	STAINLESS STEEL (AISI 316)
19	NAME PLATE	STAINLESS STEEL (AISI 304)	STAINLESS STEEL (AISI 316)

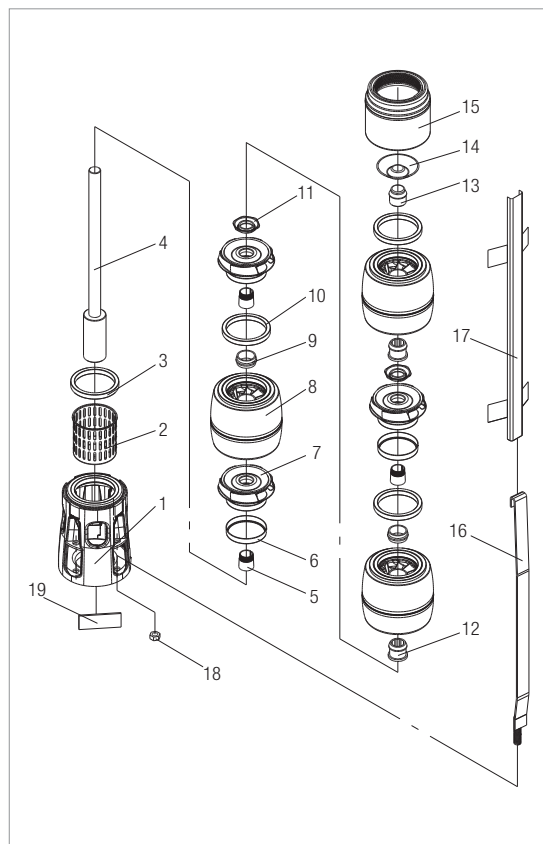

- Denomination index: (example)

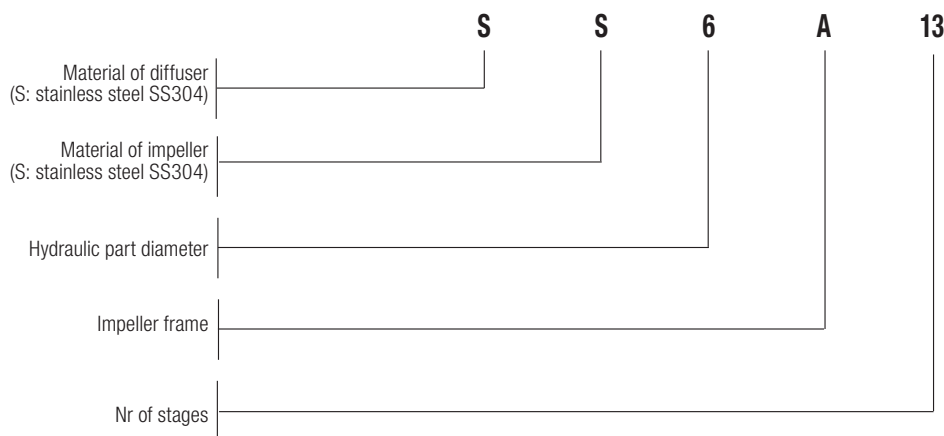

PERFORMANCE 50 HZ - 2 POLES

MODEL	ELECTRICAL DATA		HYDRAULIC DATA											STANDARD MOTOR COUPLING
	P2 NOMINAL		Q=m ³ h	0	2	4	6	8	10	12	14	16	17	
	kW	HP	Q=l/min	0	33,3	66,6	100	133,3	166,6	200	233,3	266,6	283,3	
SS6A 01	0,55	0,75	H (mt)	9	9	9	9	9	8	7	6	5	4	4"
SS6A 02	1,1	1,5		19	19	19	18	17	16	15	13	10	9	4"
SS6A 03	1,5	2		28	28	28	27	26	24	22	19	15	13	4"
SS6A 04	2,2	3		37	37	37	36	35	32	29	25	20	18	4"
SS6A 05	2,2	3		47	47	46	45	43	41	37	32	26	22	4"
SS6A 06	2,2	3		56	56	56	54	52	49	44	38	31	27	4"
SS6A 07	3	4		65	66	65	64	61	57	51	44	36	31	4"
SS6A 08	4	5,5		75	75	74	73	70	65	59	51	41	36	4" - 6"
SS6A 09	4	5,5		84	84	84	82	78	73	66	57	46	40	4" - 6"
SS6A 10	4	5,5		93	94	93	91	87	81	73	63	51	44	4" - 6"
SS6A 11	4	5,5		103	103	102	100	96	89	81	70	56	49	4" - 6"
SS6A 12	5,5	7,5		112	112	112	109	104	97	88	76	61	53	4" - 6"
SS6A 13	5,5	7,5		121	122	121	118	113	105	95	82	67	58	4" - 6"
SS6A 14	5,5	7,5		131	131	130	127	122	114	103	89	72	62	4" - 6"
SS6A 15	5,5	7,5		140	140	139	136	130	122	110	95	77	67	4" - 6"
SS6A 16	7,5	10		149	150	149	145	139	130	117	101	82	71	4" - 6"
SS6A 17	7,5	10		159	159	158	154	148	138	124	108	87	76	4" - 6"
SS6A 18	7,5	10		168	169	167	163	156	146	132	114	92	80	4" - 6"
SS6A 19	7,5	10		177	178	177	172	165	154	139	120	97	84	4" - 6"
SS6A 20	7,5	10		187	187	186	182	174	162	146	127	102	89	4" - 6"
SS6A 21	7,5	10		196	197	195	191	182	170	154	133	108	93	4" - 6"
SS6A 22	9,2	12,5		205	206	204	200	191	178	161	139	113	98	6"
SS6A 23	9,2	12,5		215	215	214	209	200	186	168	146	118	102	6"
SS6A 24	9,2	12,5		224	225	223	218	209	195	176	152	123	107	6"

ELECTRICAL DATA AND DIMENSIONS

MODEL	MOTOR *	ELECTRICAL DATA				HORIZONTAL INSTALLATION	L2 mm	L mm	L1 mm	D mm	D1 mm	TOTAL WEIGHT kg
		P2 NOMINAL		In A	OPERATING BY INVERTER							
		kW	HP									
SS6A 01	4GG	0,55	0,75	1,9	●	●	566	236	330	93	132	11,9
	4OL	0,55	0,75	2,2	●	●	614	284	330	93	132	11,5
SS6A 02	4GG	1,1	1,5	3,2	●	●	676	286	390	93	132	16,6
	4OL	1,1	1,5	3,6	●	●	724	334	390	93	132	15,7
SS6A 03	4GG	1,5	2	4,4	●	●	799	348	451	93	132	19,8
	4OL	1,5	2	4,6	●	●	805	354	451	93	132	17,7
SS6A 04	4GG	2,2	3	5,9	●	●	904	393	511	93	132	24
	4OL	2,2	3	6	●	●	969	458	511	93	132	23,4
SS6A 05	4GG	2,2	3	5,9	●	●	965	393	572	93	132	25
	4OL	2,2	3	6	●	●	1030	458	572	93	132	24,4
SS6A 06	4GG	2,2	3	5,9	●	●	1025	393	632	93	132	27
	4OL	2,2	3	6	●	●	1090	458	632	93	132	26,4
SS6A 07	4GG	3	4	8,3	●	●	1237	544	693	93	132	34,5
	4OL	3	4	7,5	●	●	1211	518	693	93	132	29,9
SS6A 08	4GG	4	5,5	10	●	●	1367	614	753	93	132	38,8
	4OL	4	5,5	9,6	●	●	1341	588	753	93	132	32,1
SS6A 08	6GF	4	5,5	10,6	●	●	1354	601	753	141	132	56
	4GG	4	5,5	10	●	●	1428	614	814	93	132	40,8
	4OL	4	5,5	9,6	●	●	1402	588	814	93	132	34,1
SS6A 09	6GF	4	5,5	10,6	●	●	1415	601	814	141	132	58
	4GG	4	5,5	10	●	●	1488	614	874	93	132	41,8
	4OL	4	5,5	9,6	●	●	1462	588	874	93	132	35,1
SS6A 10	6GF	4	5,5	10,6	●	●	1475	601	874	141	132	59
	4GG	4	5,5	10	●	●	1549	614	935	93	132	43,8
	4OL	4	5,5	9,6	●	●	1523	588	935	93	132	37,1
SS6A 11	6GF	4	5,5	10,6	●	●	1536	601	935	141	132	61
	4GG	5,5	7,5	14	●	●	1679	684	995	93	132	48,1
	4OL	5,5	7,5	13,1	●	●	1653	658	995	93	132	44,9
SS6A 12	6GF	5,5	7,5	14	●	●	1626	631	995	141	132	65
	TR6	5,5	7,5	13	○	●	1782	787	995	144	132	71
	4GG	5,5	7,5	14	●	●	1740	684	1056	93	132	50,1
SS6A 13	4OL	5,5	7,5	13,1	●	●	1714	658	1056	93	132	46,9
	6GF	5,5	7,5	14	●	●	1687	631	1056	141	132	67
	TR6	5,5	7,5	13	○	●	1843	787	1056	144	132	73
SS6A 14	4GG	5,5	7,5	14	●	●	1800	684	1116	93	132	51,1
	4OL	5,5	7,5	13,1	●	●	1774	658	1116	93	132	47,9
	6GF	5,5	7,5	14	●	●	1747	631	1116	141	132	68
SS6A 15	TR6	5,5	7,5	13	○	●	1903	787	1116	144	132	74
	4GG	5,5	7,5	14	●	●	1861	684	1177	93	132	53,1
	4OL	5,5	7,5	13,1	●	●	1835	658	1177	93	132	49,9
SS6A 16	6GF	5,5	7,5	14	●	●	1808	631	1177	141	132	70
	TR6	5,5	7,5	13	○	●	1964	787	1177	144	132	76
	4GG	7,5	10	17,4	●	●	2001	764	1237	93	132	57,8
SS6A 17	4OL	7,5	10	16,9	●	●	1975	738	1237	93	132	54,9
	6GF	7,5	10	18	●	●	1898	661	1237	141	132	74
	TR6	7,5	10	18	○	●	2054	817	1237	144	132	80
SS6A 18	4GG	7,5	10	17,4	●	●	2062	764	1298	93	132	58,8
	4OL	7,5	10	16,9	●	●	2036	738	1298	93	132	55,9
	6GF	7,5	10	18	●	●	1959	661	1298	141	132	75
SS6A 19	TR6	7,5	10	18	○	●	2115	817	1298	144	132	81
	4GG	7,5	10	17,4	●	●	2122	764	1358	93	132	60,8
	4OL	7,5	10	16,9	●	●	2096	738	1358	93	132	57,9
SS6A 20	6GF	7,5	10	18	●	●	2019	661	1358	141	132	77
	TR6	7,5	10	18	○	●	2175	817	1358	144	132	83
	4GG	7,5	10	17,4	●	●	2183	764	1419	93	132	61,8
SS6A 21	4OL	7,5	10	16,9	●	●	2157	738	1419	93	132	58,9
	6GF	7,5	10	18	●	●	2080	661	1419	141	132	78
	TR6	7,5	10	18	○	●	2236	817	1419	144	132	84
SS6A 22	4GG	7,5	10	17,4	●	●	2243	764	1479	93	132	63,8
	4OL	7,5	10	16,9	●	●	2217	738	1479	93	132	60,9
	6GF	7,5	10	18	●	●	2140	661	1479	141	132	80
SS6A 23	TR6	7,5	10	18	○	●	2296	817	1479	144	132	86
	4GG	7,5	10	17,4	●	●	2304	764	1540	93	132	64,8
	4OL	7,5	10	16,9	●	●	2278	738	1540	93	132	61,9
SS6A 24	6GF	7,5	10	18	●	●	2201	661	1540	141	132	81
	TR6	7,5	10	18	○	●	2357	817	1540	144	132	87
	6GF	9,2	12,5	22	●	●	2286	686	1600	141	132	86
SS6A 22	TR6	9,2	12,5	21	○	●	2447	847	1600	144	132	91
	6GF	9,2	12,5	22	●	●	2347	686	1661	141	132	87
SS6A 23	TR6	9,2	12,5	21	○	●	2508	847	1661	144	132	92
	6GF	9,2	12,5	22	●	●	2407	686	1721	141	132	89
SS6A 24	TR6	9,2	12,5	21	○	●	2568	847	1721	144	132	94

* **4GG motor:** 4" water-filled motor with stator immersed in thermosetting insulating resin with high heat dissipation capacity
4OL motor: 4" oil-filled rewindable motor

6GF motor: 6" encapsulated water-glycol-filled motor with stator immersed in thermosetting insulating resin
TR6 motor: 6" water-filled rewindable motor

● Allowed
○ Only PE2 + PA version

SS6A

SUBMERSIBLE PUMPS

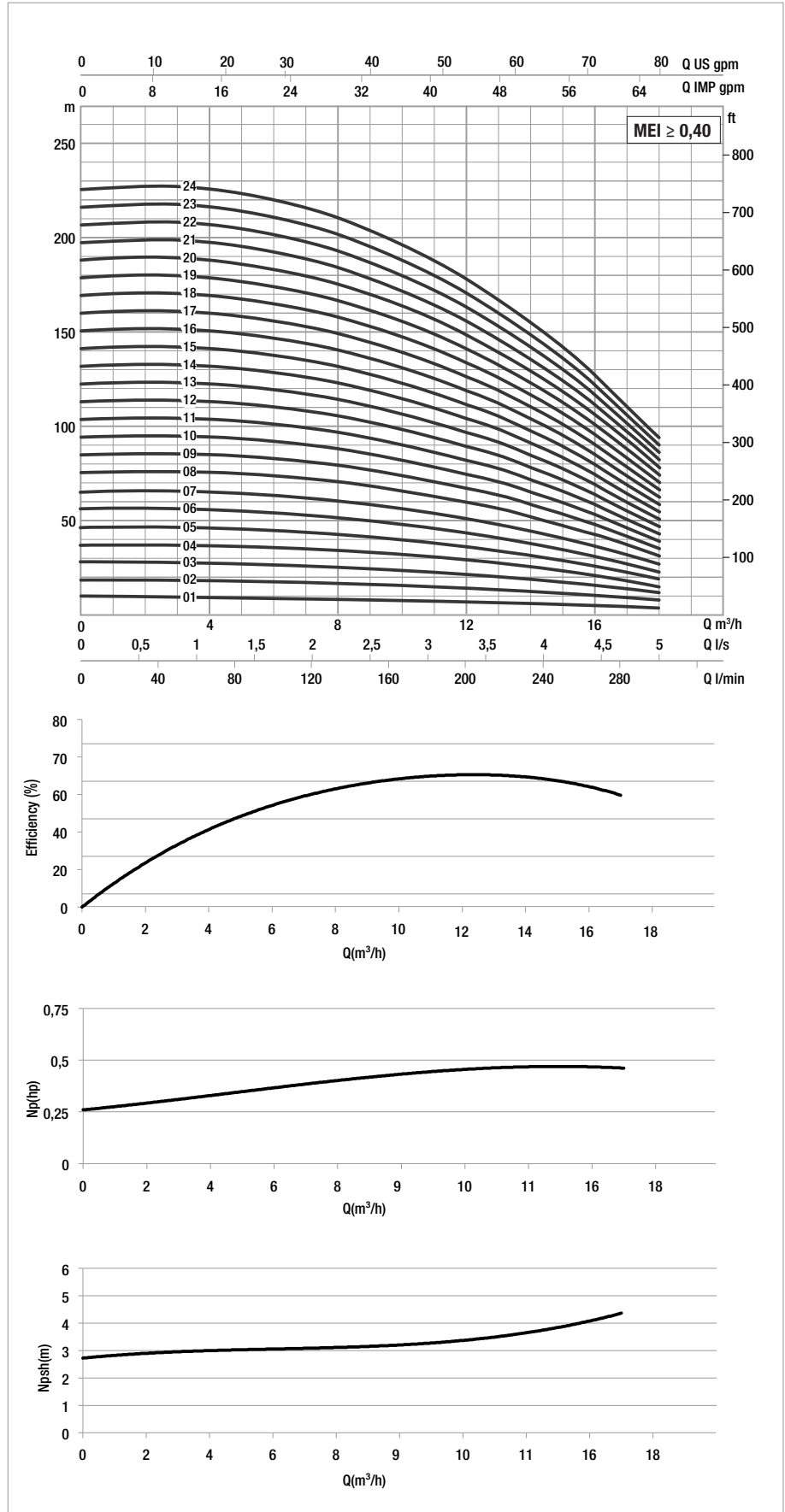
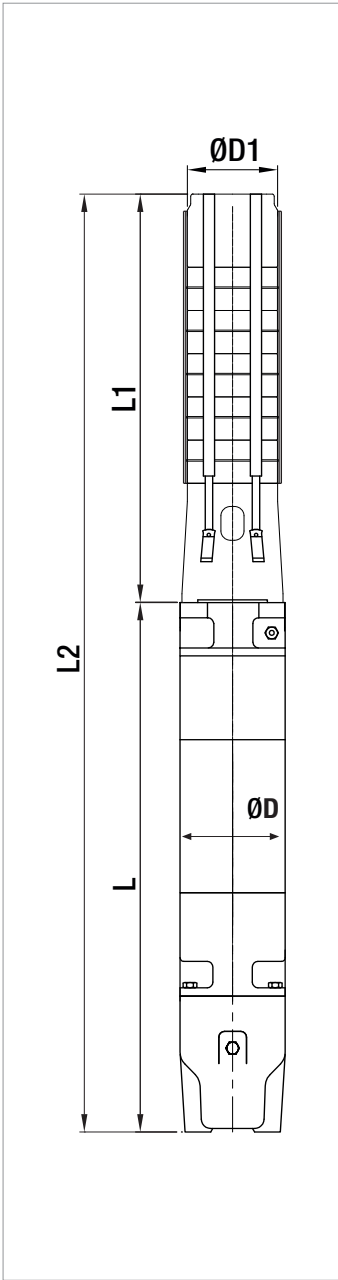

Performance 50 Hz - 2 poles. The performance curves are based on the kinematic viscosity values = 1 mm²/s and density equal to 1000 kg/m³. Curve tolerance according to ISO 9906. For the MEI index, refer to the hydraulic efficiency section

PERFORMANCE 50 HZ - 2 POLES

MODEL	ELECTRICAL DATA		Q=m ³ h Q=l/min	HYDRAULIC DATA										STANDARD MOTOR COUPLING
	P2 NOMINAL			0	2	4	6	8	10	12	14	16	17	
	kW	HP		0	33,3	66,6	100	133,3	166,6	200	233,3	266,6	283,3	
SS6A 25	9,2	12,5	H (mt)	233	234	232	227	217	203	183	158	128	111	6"
SS6A 26	9,2	12,5		243	244	242	236	226	211	190	165	133	116	6"
SS6A 27	11	15		252	253	251	245	235	219	198	171	138	120	6"
SS6A 28	11	15		261	262	260	254	243	227	205	177	143	124	6"
SS6A 29	11	15		270	272	270	263	252	235	212	184	149	129	6"
SS6A 30	11	15		280	281	279	272	261	243	220	190	154	133	6"
SS6A 31	13	17,5		289	290	288	281	269	251	227	196	159	138	6"
SS6A 32	13	17,5		298	300	297	290	278	259	234	202	164	142	6"
SS6A 33	13	17,5		308	309	307	300	287	268	242	209	169	147	6"
SS6A 34	13	17,5		317	318	316	309	295	276	249	215	174	151	6"
SS6A 35	13	17,5		326	328	325	318	304	284	256	221	179	156	6"
SS6A 36	13	17,5		336	337	335	327	313	292	264	228	184	160	6"
SS6A 37	13	17,5		345	347	344	336	321	300	271	234	190	164	6"
SS6A 38	15	20		354	356	353	345	330	308	278	240	195	169	6"
SS6A 39	15	20		364	365	362	354	339	316	286	247	200	173	6"
SS6A 40	15	20		373	375	372	363	348	324	293	253	205	178	6"
SS6A 41	15	20		382	384	381	372	356	332	300	259	210	182	6"
SS6A 42	18,5	25		392	393	390	381	365	341	308	266	215	187	6"

ELECTRICAL DATA AND DIMENSIONS

MODEL	MOTOR *	ELECTRICAL DATA				HORIZONTAL INSTALLATION	L2 mm	L mm	L1 mm	D mm	D1 mm	TOTAL WEIGHT kg
		P2 NOMINAL		In A	OPERATING BY INVERTER							
		kW	HP									
SS6A 25	6GF	9,2	12,5	22	●	●	2468	686	1782	141	132	90
	TR6	9,2	12,5	21	○	●	2629	847	1782	144	132	95
SS6A 26	6GF	9,2	12,5	22	●	●	2528	686	1842	141	132	91
	TR6	9,2	12,5	21	○	●	2689	847	1842	144	132	96
SS6A 27	6GF	11	15	25,5	●	●	2634	731	1903	141	132	98
	TR6	11	15	25	○	●	2780	877	1903	144	132	103
SS6A 28	6GF	11	15	25,5	●	●	2694	731	1963	141	132	99
	TR6	11	15	25	○	●	2840	877	1963	144	132	104
SS6A 29	6GF	11	15	25,5	●	●	2755	731	2024	141	132	101
	TR6	11	15	25	○	●	2901	877	2024	144	132	106
SS6A 30	6GF	11	15	25,5	●	●	2815	731	2084	141	132	102
	TR6	11	15	25	○	●	2961	877	2084	144	132	107
SS6A 31	6GF	13	17,5	28,7	●	●	2906	761	2145	141	132	107
	TR6	13	17,5	29	○	●	3052	907	2145	144	132	114
SS6A 32	6GF	13	17,5	28,7	●	●	2966	761	2205	141	132	108
	TR6	13	17,5	29	○	●	3112	907	2205	144	132	115
SS6A 33	6GF	13	17,5	28,7	●	●	3027	761	2266	141	132	110
	TR6	13	17,5	29	○	●	3173	907	2266	144	132	117
SS6A 34	6GF	13	17,5	28,7	●	●	3087	761	2326	141	132	111
	TR6	13	17,5	29	○	●	3233	907	2326	144	132	118
SS6A 35	6GF	13	17,5	28,7	●	●	3148	761	2387	141	132	112
	TR6	13	17,5	29	○	●	3294	907	2387	144	132	119
SS6A 36	6GF	13	17,5	28,7	●	●	3208	761	2447	141	132	114
	TR6	13	17,5	29	○	●	3354	907	2447	144	132	121
SS6A 37	6GF	13	17,5	28,7	●	●	3269	761	2508	141	132	115
	TR6	13	17,5	29	○	●	3415	907	2508	144	132	122
SS6A 38	6GF	15	20	33,4	●	●	3354	786	2568	141	132	120
	TR6	15	20	32	○	●	3545	977	2568	144	132	136
SS6A 39	6GF	15	20	33,4	●	●	3665	786	2879	141	167	152
	TR6	15	20	32	○	●	3856	977	2879	144	167	168
SS6A 40	6GF	15	20	33,4	●	●	3725	786	2939	141	167	153
	TR6	15	20	32	○	●	3916	977	2939	144	167	169
SS6A 41	6GF	15	20	33,4	●	●	3786	786	3000	141	167	155
	TR6	15	20	32	○	●	3977	977	3000	144	167	171
SS6A 42	6GF	18,5	25	41	●	●	3921	861	3060	141	167	165
	TR6	18,5	25	39	○	●	4097	1037	3060	144	167	176

* 6GF motor: 6" encapsulated water-glycol-filled motor with stator immersed in thermosetting insulating resin
 TR6 motor: 6" water-filled rewindable motor

●	Allowed
○	Only PE2 + PA version

SS6A

SUBMERSIBLE PUMPS

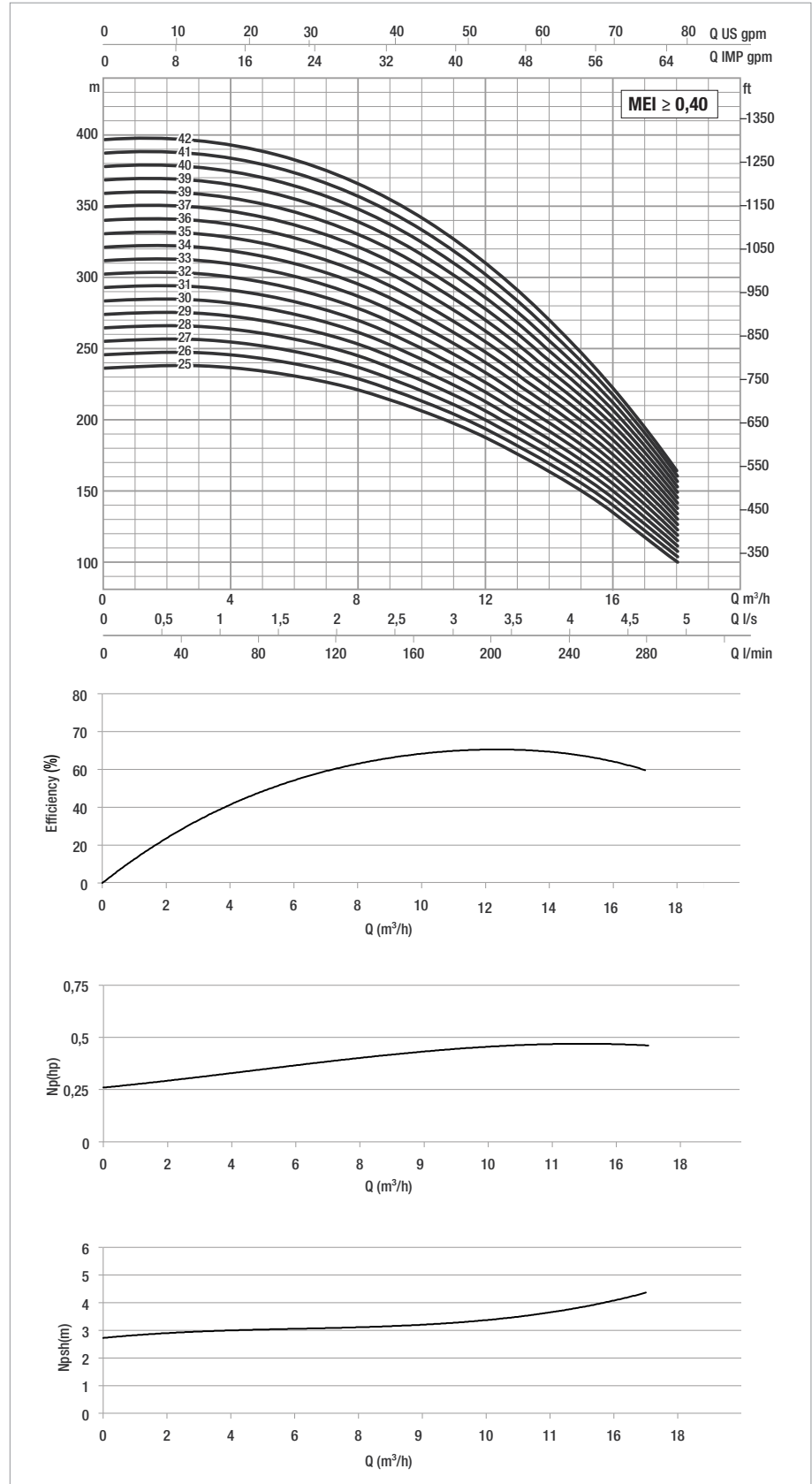
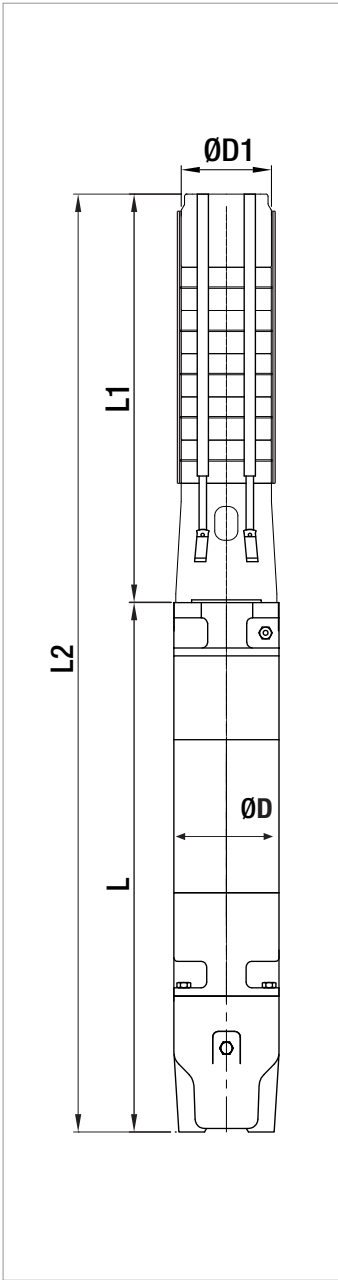

Performance 50 Hz - 2 poles. The performance curves are based on the kinematic viscosity values = 1 mm²/s and density equal to 1000 kg/m³. Curve tolerance according to ISO 9906.
For the MEI index, refer to the hydraulic efficiency section

PERFORMANCE 50 HZ - 2 POLES

MODEL	ELECTRICAL DATA		HYDRAULIC DATA											STANDARD MOTOR COUPLING
	P2 NOMINAL		Q=m ³ h	0	2	4	6	8	10	12	14	16	17	
	kW	HP	Q=l/min	0	33,3	66,6	100	133,3	166,6	200	233,3	266,6	283,3	
SS6A 43	18,5	25	H (mt)	401	403	400	390	374	349	315	272	220	191	6"
SS6A 44	18,5	25		410	412	409	399	382	357	322	278	225	196	6"
SS6A 45	18,5	25		420	421	418	408	391	365	330	285	231	200	6"
SS6A 46	18,5	25		429	431	428	418	400	373	337	291	236	204	6"
SS6A 47	18,5	25		438	440	437	427	408	381	344	297	241	209	6"
SS6A 48	18,5	25		448	450	446	436	417	389	352	304	246	213	6"
SS6A 49	18,5	25		457	459	455	445	426	397	359	310	251	218	6"
SS6A 50	22	30		466	468	465	454	434	405	366	316	256	222	6"
SS6A 51	22	30		476	478	474	463	443	414	373	323	261	227	6"
SS6A 52	22	30		485	487	483	472	452	422	381	329	266	231	6"
SS6A 53	22	30		494	496	493	481	460	430	388	335	272	236	6"
SS6A 54	22	30		504	506	502	490	469	438	395	342	277	240	6"
SS6A 55	22	30		513	515	511	499	478	446	403	348	282	244	6"
SS6A 56	22	30		522	524	520	508	487	454	410	354	287	249	6"
SS6A 57	22	30		532	534	530	517	495	462	417	361	292	253	6"
SS6A 58	22	30		541	543	539	526	504	470	425	367	297	258	6"
SS6A 59	22	30		550	553	548	536	513	478	432	373	302	262	6"
SS6A 60	22	30		560	562	558	545	521	486	439	380	307	267	6"

ELECTRICAL DATA AND DIMENSIONS

MODEL	MOTOR *	ELECTRICAL DATA				HORIZONTAL INSTALLATION	L2 mm	L mm	L1 mm	D mm	D1 mm	TOTAL WEIGHT kg
		P2 NOMINAL		In A	OPERATING BY INVERTER							
		kW	HP									
SS6A 43	6GF	18,5	25	41	●	●	3982	861	3121	141	167	167
	TR6	18,5	25	39	○	●	4158	1037	3121	144	167	178
SS6A 44	6GF	18,5	25	41	●	●	4042	861	3181	141	167	169
	TR6	18,5	25	39	○	●	4218	1037	3181	144	167	180
SS6A 45	6GF	18,5	25	41	●	●	4103	861	3242	141	167	170
	TR6	18,5	25	39	○	●	4279	1037	3242	144	167	181
SS6A 46	6GF	18,5	25	41	●	●	4163	861	3302	141	167	172
	TR6	18,5	25	39	○	●	4339	1037	3302	144	167	183
SS6A 47	6GF	18,5	25	41	●	●	4224	861	3363	141	167	174
	TR6	18,5	25	39	○	●	4400	1037	3363	144	167	185
SS6A 48	6GF	18,5	25	41	●	●	4284	861	3423	141	167	176
	TR6	18,5	25	39	○	●	4460	1037	3423	144	167	187
SS6A 49	6GF	18,5	25	41	●	●	4345	861	3484	141	167	177
	TR6	18,5	25	39	○	●	4521	1037	3484	144	167	188
SS6A 50	6GF	22	30	47	●	●	4465	921	3544	141	167	184
	TR6	22	30	49	○	●	4611	1067	3544	144	167	205
SS6A 51	6GF	22	30	47	●	●	4526	921	3605	141	167	186
	TR6	22	30	49	○	●	4672	1067	3605	144	167	207
SS6A 52	6GF	22	30	47	●	●	4586	921	3665	141	167	188
	TR6	22	30	49	○	●	4732	1067	3665	144	167	209
SS6A 53	6GF	22	30	47	●	●	4647	921	3726	141	167	190
	TR6	22	30	49	○	●	4793	1067	3726	144	167	211
SS6A 54	6GF	22	30	47	●	●	4707	921	3786	141	167	191
	TR6	22	30	49	○	●	4853	1067	3786	144	167	212
SS6A 55	6GF	22	30	47	●	●	4768	921	3847	141	167	193
	TR6	22	30	49	○	●	4914	1067	3847	144	167	214
SS6A 56	6GF	22	30	47	●	●	4828	921	3907	141	167	195
	TR6	22	30	49	○	●	4974	1067	3907	144	167	216
SS6A 57	6GF	22	30	47	●	●	4889	921	3968	141	167	197
	TR6	22	30	49	○	●	5035	1067	3968	144	167	218
SS6A 58	6GF	22	30	47	●	●	4949	921	4028	141	167	199
	TR6	22	30	49	○	●	5095	1067	4028	144	167	220
SS6A 59	6GF	22	30	47	●	●	5010	921	4089	141	167	200
	TR6	22	30	49	○	●	5156	1067	4089	144	167	221
SS6A 60	6GF	22	30	47	●	●	5070	921	4149	141	167	202
	TR6	22	30	49	○	●	5216	1067	4149	144	167	223

* **6GF motor:** 6" encapsulated water-glycol-filled motor with stator immersed in thermosetting insulating resin
TR6 motor: 6" water-filled rewindable motor

●	Allowed
○	Only PE2 + PA version

SS6A

SUBMERSIBLE PUMPS

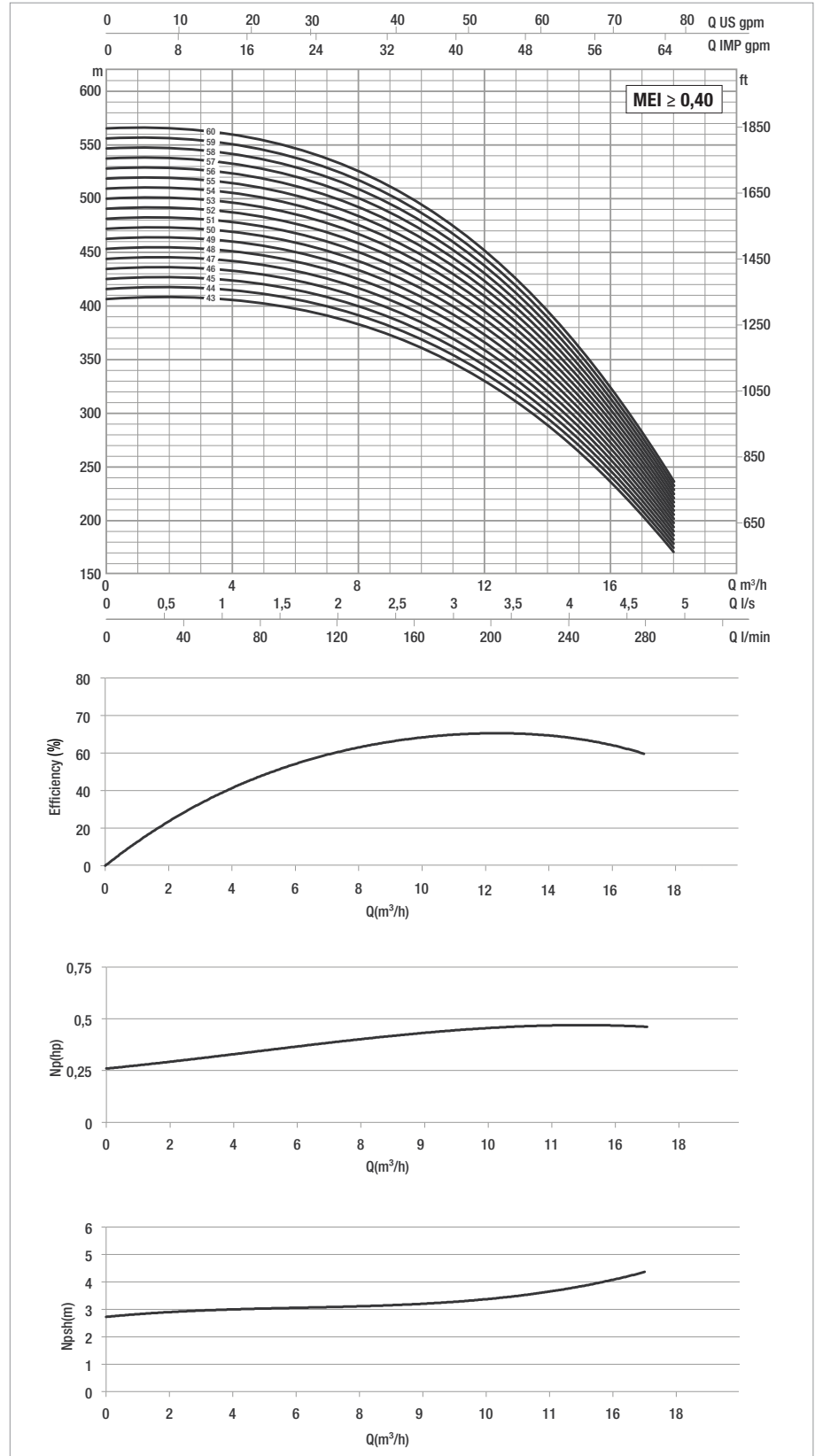
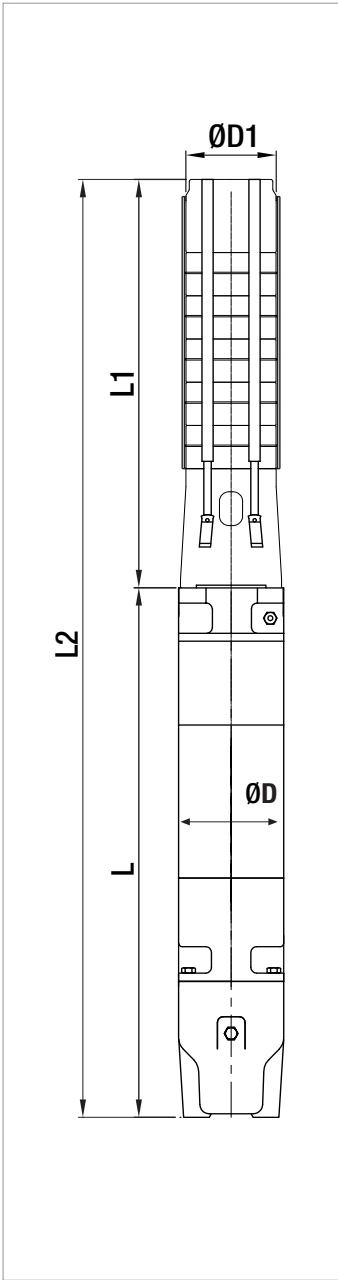

Performance 50 Hz - 2 poles. The performance curves are based on the kinematic viscosity values = 1 mm²/s and density equal to 1000 kg/m³. Curve tolerance according to ISO 9906.
For the MEI index, refer to the hydraulic efficiency section

PERFORMANCE 50 HZ - 2 POLES

MODEL	ELECTRICAL DATA		HYDRAULIC DATA											STANDARD MOTOR COUPLING
	P2 NOMINAL		Q=m ³ h	0	6	8	10	12	14	15	16	18	20	
	kW	HP	Q=l/min	0	100	133,3	166,6	200	233,3	250	266,6	300	333,3	
SS6B 01	0,75	1	H (mt)	11	11	11	10	10	9	9	9	8	6	4"
SS6B 02	1,5	2		23	22	22	21	20	19	18	17	15	13	4"
SS6B 03	2,2	3		34	33	33	31	30	28	27	26	23	19	4"
SS6B 04	3	4		45	44	43	42	40	37	36	34	30	26	4"
SS6B 05	3	4		56	55	54	52	50	47	45	43	38	32	4"
SS6B 06	4	5,5		68	66	65	63	60	56	54	51	45	39	4" - 6"
SS6B 07	4	5,5		79	77	76	73	70	65	63	60	53	45	4" - 6"
SS6B 08	5,5	7,5		90	89	87	84	80	75	71	68	60	52	4" - 6"
SS6B 09	5,5	7,5		102	100	98	94	90	84	80	77	68	58	4" - 6"
SS6B 10	5,5	7,5		113	111	108	105	100	93	89	85	76	65	4" - 6"
SS6B 11	7,5	10		124	122	119	115	110	102	98	94	83	71	4" - 6"
SS6B 12	7,5	10		135	133	130	126	120	112	107	102	91	78	4" - 6"
SS6B 13	7,5	10		147	144	141	136	130	121	116	111	98	84	4" - 6"
SS6B 14	7,5	10		158	155	152	147	140	130	125	119	106	91	4" - 6"
SS6B 15	9,3	12,5		169	166	163	157	150	140	134	128	113	97	6"
SS6B 16	9,3	12,5		181	177	173	168	160	149	143	136	121	103	6"
SS6B 17	9,3	12,5		192	188	184	178	170	158	152	145	128	110	6"
SS6B 18	11	15		203	199	195	189	180	168	161	153	136	116	6"
SS6B 19	11	15		214	210	206	199	190	177	170	162	143	123	6"
SS6B 20	11	15		226	221	217	210	199	186	179	170	151	129	6"
SS6B 21	13	17,5		237	232	228	220	209	196	188	179	159	136	6"
SS6B 22	13	17,5		248	243	238	230	219	205	196	187	166	142	6"
SS6B 23	13	17,5		260	254	249	241	229	214	205	196	174	149	6"
SS6B 24	13	17,5		271	266	260	251	239	224	214	204	181	155	6"
SS6B 25	15	20		282	277	271	262	249	233	223	213	189	162	6"
SS6B 26	15	20		293	288	282	272	259	242	232	221	196	168	6"
SS6B 27	15	20		305	299	293	283	269	252	241	230	204	175	6"

ELECTRICAL DATA AND DIMENSIONS

MODEL	MOTOR *	ELECTRICAL DATA				HORIZONTAL INSTALLATION	L2 mm	L mm	L1 mm	D mm	D1 mm	TOTAL WEIGHT kg
		P2 NOMINAL		In A	OPERATING BY INVERTER							
		kW	HP									
SS6B 01	4GG	0,75	1	2,4	●	●	596	266	330	93	132	13,6
	40L	0,75	1	2,6	●	●	634	304	330	93	132	12,4
SS6B 02	4GG	1,5	2	4,4	●	●	738	348	390	93	132	18,3
	40L	1,5	2	4,6	●	●	744	354	390	93	132	16,2
SS6B 03	4GG	2,2	3	5,9	●	●	844	393	451	93	132	22
	40L	2,2	3	6	●	●	909	458	451	93	132	21,4
SS6B 04	4GG	3	4	8,3	●	●	1055	544	511	93	132	30
	40L	3	4	7,5	●	●	1029	518	511	93	132	25,4
SS6B 05	4GG	3	4	8,3	●	●	1116	544	572	93	132	31,5
	40L	3	4	7,5	●	●	1090	518	572	93	132	26,9
SS6B 06	4GG	4	5,5	10	●	●	1246	614	632	93	132	36,3
	40L	4	5,5	9,6	●	●	1220	588	632	93	132	29,6
	6GF	4	5,5	10,6	●	●	1233	601	632	141	132	53,5
SS6B 07	4GG	4	5,5	10	●	●	1307	614	693	93	132	37,8
	40L	4	5,5	9,6	●	●	1281	588	693	93	132	31,1
	6GF	4	5,5	10,6	●	●	1294	601	693	141	132	55
SS6B 08	4GG	5,5	7,5	14	●	●	1437	684	753	93	132	43,1
	40L	5,5	7,5	13,1	●	●	1411	658	753	93	132	39,9
	6GF	5,5	7,5	14	●	●	1384	631	753	141	132	60
	TR6	5,5	7,5	13	○	●	1540	787	753	144	132	66
SS6B 09	4GG	5,5	7,5	14	●	●	1498	684	814	93	132	44,1
	40L	5,5	7,5	13,1	●	●	1472	658	814	93	132	40,9
	6GF	5,5	7,5	14	●	●	1445	631	814	141	132	61
	TR6	5,5	7,5	13	○	●	1601	787	814	144	132	67
SS6B 10	4GG	5,5	7,5	14	●	●	1558	684	874	93	132	45,1
	40L	5,5	7,5	13,1	●	●	1532	658	874	93	132	41,9
	6GF	5,5	7,5	14	●	●	1505	631	874	141	132	62
	TR6	5,5	7,5	13	○	●	1661	787	874	144	132	68
SS6B 11	4GG	7,5	10	17,4	●	●	1699	764	935	93	132	50,8
	40L	7,5	10	16,9	●	●	1673	738	935	93	132	47,9
	6GF	7,5	10	18	●	●	1596	661	935	141	132	67
	TR6	7,5	10	18	○	●	1752	817	935	144	132	73
SS6B 12	4GG	7,5	10	17,4	●	●	1759	764	995	93	132	51,8
	40L	7,5	10	16,9	●	●	1733	738	995	93	132	48,9
	6GF	7,5	10	18	●	●	1656	661	995	141	132	68
	TR6	7,5	10	18	○	●	1812	817	995	144	132	74
SS6B 13	4GG	7,5	10	17,4	●	●	1820	764	1056	93	132	53,8
	40L	7,5	10	16,9	●	●	1794	738	1056	93	132	50,9
	6GF	7,5	10	18	●	●	1717	661	1056	141	132	70
	TR6	7,5	10	18	○	●	1873	817	1056	144	132	76
SS6B 14	4GG	7,5	10	17,4	●	●	1880	764	1116	93	132	54,8
	40L	7,5	10	16,9	●	●	1854	738	1116	93	132	51,9
	6GF	7,5	10	18	●	●	1777	661	1116	141	132	71
	TR6	7,5	10	18	○	●	1933	817	1116	144	132	77
SS6B 15	6GF	9,3	12,5	22	●	●	1863	686	1177	141	132	76
	TR6	9,3	12,5	21	○	●	2024	847	1177	144	132	81
SS6B 16	6GF	9,3	12,5	22	●	●	1923	686	1237	141	132	77
	TR6	9,3	12,5	21	○	●	2084	847	1237	144	132	82
SS6B 17	6GF	9,3	12,5	22	●	●	1984	686	1298	141	132	79
	TR6	9,3	12,5	21	○	●	2145	847	1298	144	132	84
SS6B 18	6GF	11	15	25,5	●	●	2089	731	1358	141	132	85
	TR6	11	15	25	○	●	2235	877	1358	144	132	90
SS6B 19	6GF	11	15	25,5	●	●	2150	731	1419	141	132	86
	TR6	11	15	25	○	●	2296	877	1419	144	132	91
SS6B 20	6GF	11	15	25,5	●	●	2210	731	1479	141	132	88
	TR6	11	15	25	○	●	2356	877	1479	144	132	93
SS6B 21	6GF	13	17,5	28,7	●	●	2301	761	1540	141	132	92
	TR6	13	17,5	29	○	●	2447	907	1540	144	132	99
SS6B 22	6GF	13	17,5	28,7	●	●	2361	761	1600	141	132	94
	TR6	13	17,5	29	○	●	2507	907	1600	144	132	101
SS6B 23	6GF	13	17,5	28,7	●	●	2422	761	1661	141	132	95
	TR6	13	17,5	29	○	●	2568	907	1661	144	132	102
SS6B 24	6GF	13	17,5	28,7	●	●	2482	761	1721	141	132	97
	TR6	13	17,5	29	○	●	2628	907	1721	144	132	104
SS6B 25	6GF	15	20	33,4	●	●	2568	786	1782	141	132	101
	TR6	15	20	32	○	●	2759	977	1782	144	132	117
SS6B 26	6GF	15	20	33,4	●	●	2628	786	1842	141	132	103
	TR6	15	20	32	○	●	2819	977	1842	144	132	119
SS6B 27	6GF	15	20	33,4	●	●	2689	786	1903	141	132	104
	TR6	15	20	32	○	●	2880	977	1903	144	132	120

* 4GG motor: 4" water-filled motor with stator immersed in thermosetting insulating resin with high heat dissipation capacity
 40L motor: 4" oil-filled rewindable motor

6GF motor: 6" encapsulated water-glycol-filled motor with stator immersed in thermosetting insulating resin
 TR6 motor: 6" water-filled rewindable motor

● Allowed
 ○ Only PE2 + PA version

SS6B

SUBMERSIBLE PUMPS

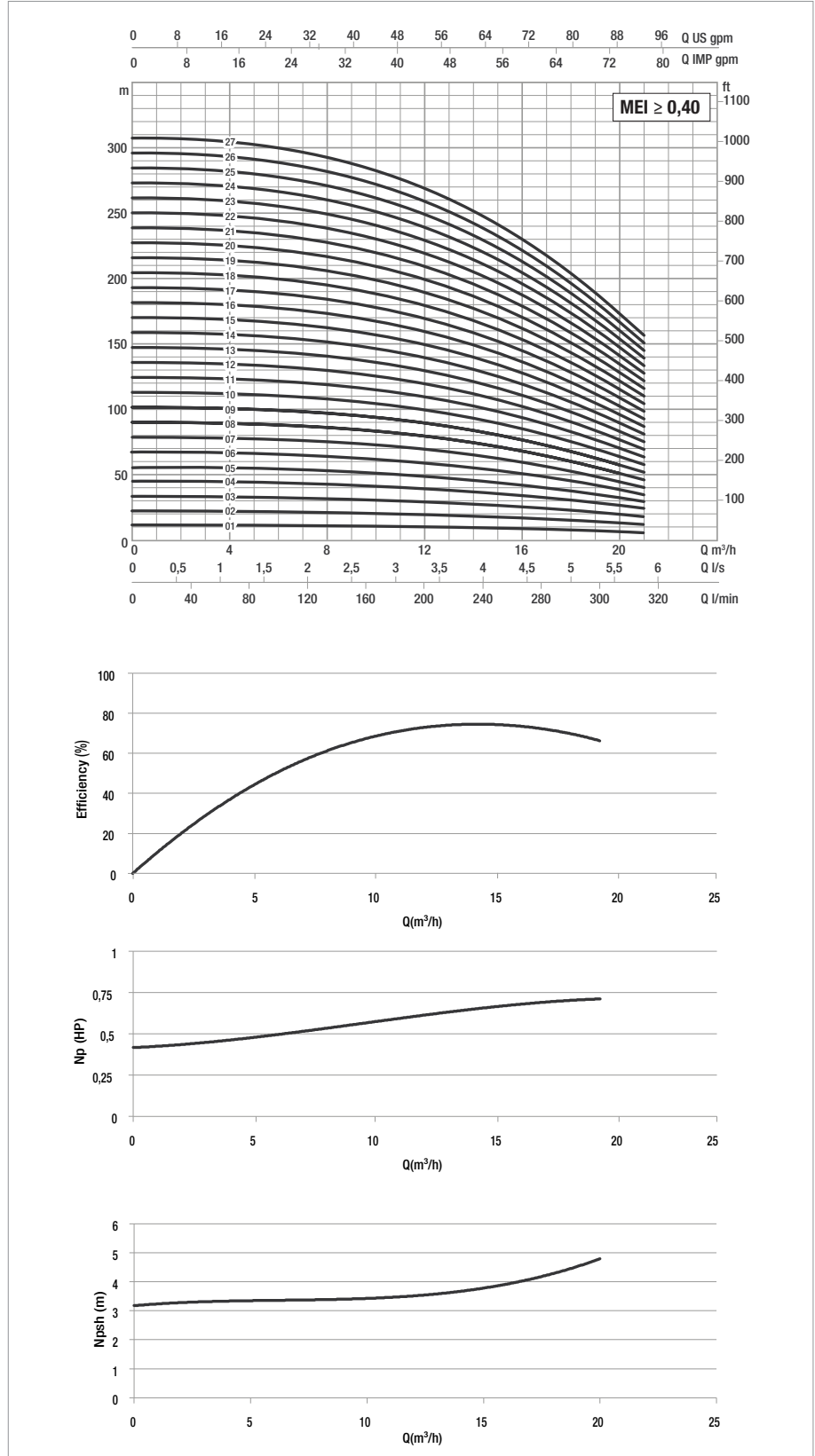
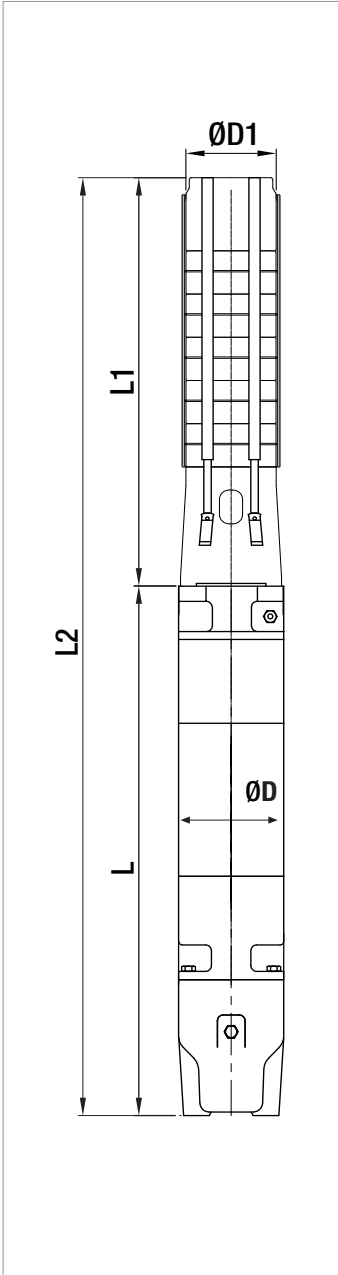

Performance 50 Hz - 2 poles. The performance curves are based on the kinematic viscosity values = $1 \text{ mm}^2/\text{s}$ and density equal to $1000 \text{ kg}/\text{m}^3$. Curve tolerance according to ISO 9906.
For the MEI index, refer to the hydraulic efficiency section

PERFORMANCE 50 HZ - 2 POLES

MODEL	ELECTRICAL DATA		Q=m ³ h Q=l/min	HYDRAULIC DATA										STANDARD MOTOR COUPLING
	P2 NOMINAL			0	6	8	10	12	14	15	16	18	20	
	kW	HP		0	100	133,3	166,6	200	233,3	250	266,6	300	333,3	
SS6B 28	15	20	H (mt)	316	310	303	293	279	261	250	238	211	181	6"
SS6B 29	18,5	25		327	321	314	304	289	270	259	247	219	188	6"
SS6B 30	18,5	25		339	332	325	314	299	280	268	255	227	194	6"
SS6B 31	18,5	25		350	343	336	325	309	289	277	264	234	200	6"
SS6B 32	18,5	25		361	354	347	335	319	298	286	272	242	207	6"
SS6B 33	18,5	25		372	365	358	346	329	307	295	281	249	213	6"
SS6B 34	18,5	25		384	376	368	356	339	317	304	289	257	220	6"
SS6B 35	22	30		395	387	379	367	349	326	313	298	264	226	6"
SS6B 36	22	30		406	398	390	377	359	335	322	306	272	233	6"
SS6B 37	22	30		418	409	401	388	369	345	330	315	279	239	6"
SS6B 38	22	30		429	420	412	398	379	354	339	323	287	246	6"
SS6B 39	22	30		440	432	423	409	389	363	348	332	294	252	6"
SS6B 40	22	30		451	443	433	419	399	373	357	340	302	259	6"
SS6B 41	22	30		463	454	444	430	409	382	366	349	310	265	6"
SS6B 42	26	35		474	465	455	440	419	391	375	357	317	272	6"
SS6B 43	26	35		485	476	466	450	429	401	384	366	325	278	6"

ELECTRICAL DATA AND DIMENSIONS

MODEL	MOTOR *	ELECTRICAL DATA				HORIZONTAL INSTALLATION	L2 mm	L mm	L1 mm	D mm	D1 mm	TOTAL WEIGHT kg
		P2 NOMINAL		In A	OPERATING BY INVERTER							
		kW	HP									
SS6B 28	6GF	15	20	33,4	●	●	2749	786	1963	141	132	106
	TR6	15	20	32	○	●	2940	977	1963	144	132	122
SS6B 29	6GF	18,5	25	41	●	●	2885	861	2024	141	132	115
	TR6	18,5	25	39	○	●	3061	1037	2024	144	132	126
SS6B 30	6GF	18,5	25	41	●	●	2945	861	2084	141	132	116
	TR6	18,5	25	39	○	●	3121	1037	2084	144	132	127
SS6B 31	6GF	18,5	25	41	●	●	3006	861	2145	141	132	118
	TR6	18,5	25	39	○	●	3182	1037	2145	144	132	129
SS6B 32	6GF	18,5	25	41	●	●	3066	861	2205	141	132	119
	TR6	18,5	25	39	○	●	3242	1037	2205	144	132	130
SS6B 33	6GF	18,5	25	41	●	●	3127	861	2266	141	132	121
	TR6	18,5	25	39	○	●	3303	1037	2266	144	132	132
SS6B 34	6GF	18,5	25	41	●	●	3187	861	2326	141	132	122
	TR6	18,5	25	39	○	●	3363	1037	2326	144	132	133
SS6B 35	6GF	22	30	47	●	●	3308	921	2387	141	132	129
	TR6	22	30	49	○	●	3454	1067	2387	144	132	150
SS6B 36	6GF	22	30	47	●	●	3368	921	2447	141	132	130
	TR6	22	30	49	○	●	3514	1067	2447	144	132	151
SS6B 37	6GF	22	30	47	●	●	3429	921	2508	141	132	132
	TR6	22	30	49	○	●	3575	1067	2508	144	132	153
SS6B 38	6GF	22	30	47	●	●	3489	921	2568	141	132	133
	TR6	22	30	49	○	●	3635	1067	2568	144	132	154
SS6B 39	6GF	22	30	47	●	●	3800	921	2879	141	167	165
	TR6	22	30	49	○	●	3946	1067	2879	144	167	186
SS6B 40	6GF	22	30	47	●	●	3860	921	2939	141	167	167
	TR6	22	30	49	○	●	4006	1067	2939	144	167	188
SS6B 41	6GF	22	30	47	●	●	3921	921	3000	141	167	169
	TR6	22	30	49	○	●	4067	1067	3000	144	167	190
SS6B 42	6GF	26	35	57	●	●	4040	980	3060	141	167	174
	TR6	26	35	58	○	●	4197	1137	3060	144	167	201
SS6B 43	6GF	26	35	57	●	●	4101	980	3121	141	167	176
	TR6	26	35	58	○	●	4258	1137	3121	144	167	203

* **6GF motor:** 6" encapsulated water-glycol-filled motor with stator immersed in thermosetting insulating resin
TR6 motor: 6" water-filled rewindable motor

●	Allowed
○	Only PE2 + PA version

SS6B

SUBMERSIBLE PUMPS

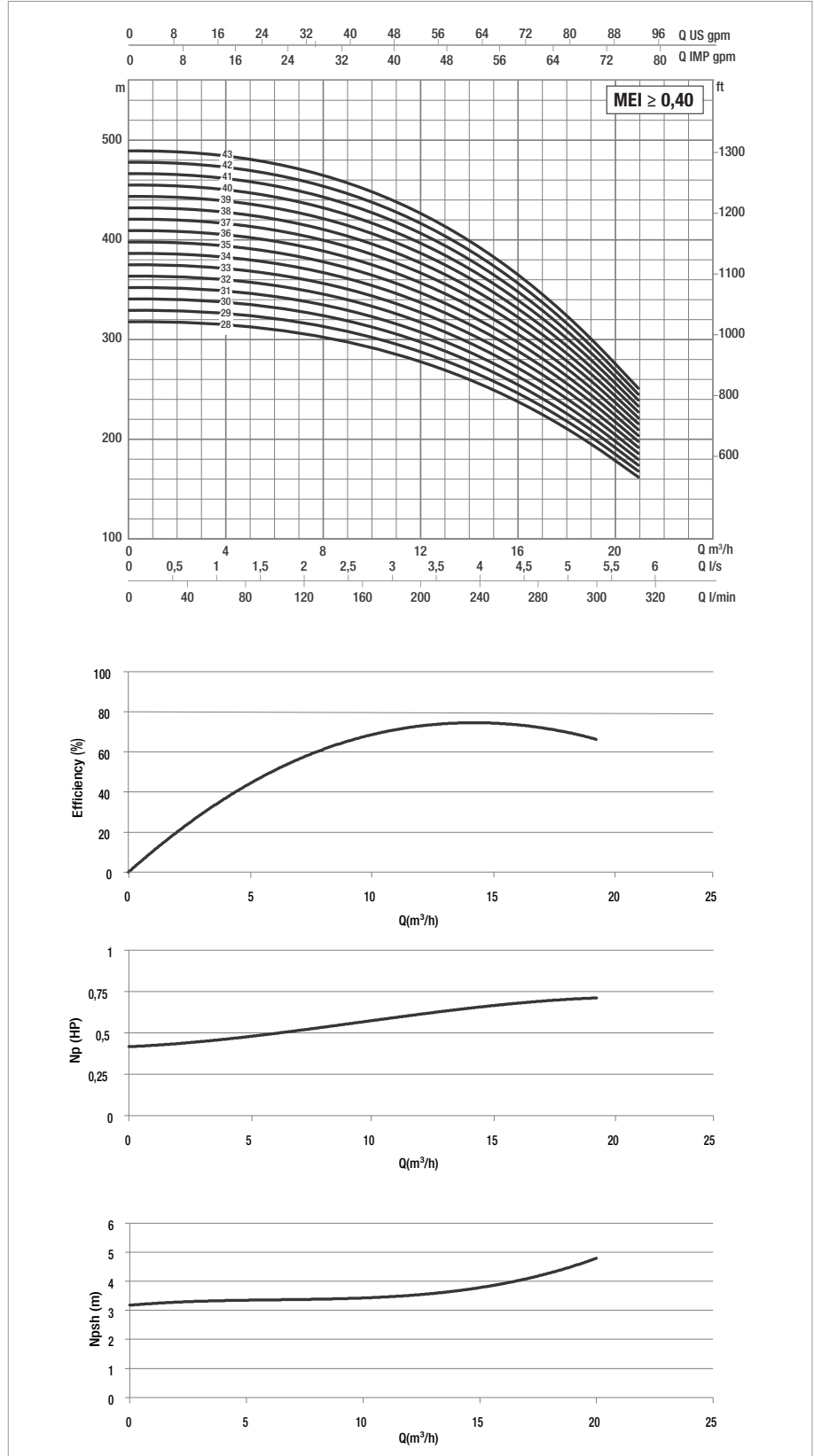
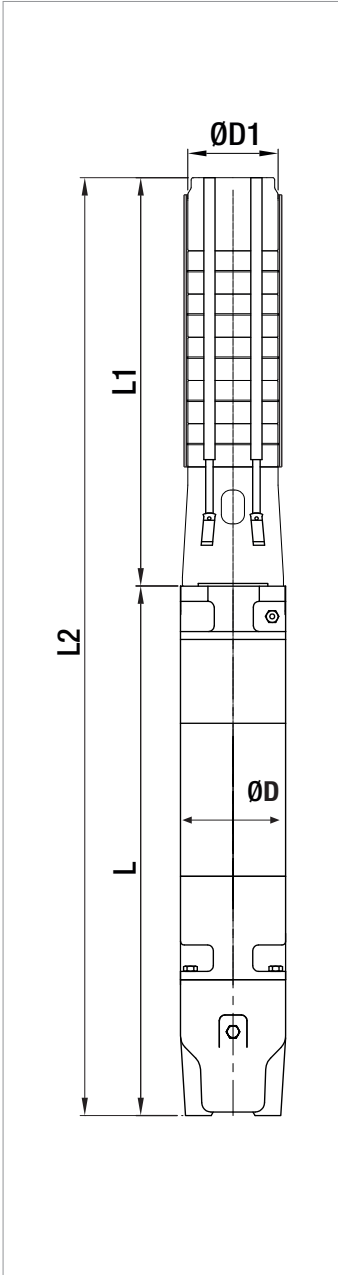

Performance 50 Hz - 2 poles. The performance curves are based on the kinematic viscosity values = 1 mm²/s and density equal to 1000 kg/m³. Curve tolerance according to ISO 9906.

For the MEI index, refer to the hydraulic efficiency section

PERFORMANCE 50 HZ - 2 POLES

MODEL	ELECTRICAL DATA		HYDRAULIC DATA											STANDARD MOTOR COUPLING
	P2 NOMINAL		Q=m ³ h	0	6	8	10	12	14	15	16	18	20	
	kW	HP	Q=l/min	0	100	133,3	166,6	200	233,3	250	266,6	300	333,3	
SS6B 44	26	35	H (m)	497	487	477	461	439	410	393	374	332	284	6"
SS6B 45	26	35		508	498	488	471	449	419	402	383	340	291	6"
SS6B 46	26	35		519	509	498	482	459	429	411	391	347	297	6"
SS6B 47	26	35		531	520	509	492	469	438	420	400	355	304	6"
SS6B 48	26	35		542	531	520	503	479	447	429	408	362	310	6"
SS6B 49	30	40		553	542	531	513	489	457	438	417	370	317	6"
SS6B 50	30	40		564	553	542	524	499	466	447	425	378	323	6"
SS6B 51	30	40		576	564	553	534	509	475	456	434	385	330	6"
SS6B 52	30	40		587	575	563	545	519	485	464	442	393	336	6"
SS6B 53	30	40		598	586	574	555	529	494	473	451	400	343	6"
SS6B 54	30	40		610	597	585	566	539	503	482	459	408	349	6"
SS6B 55	30	40		621	609	596	576	549	512	491	468	415	356	6"
SS6B 56	30	40		632	620	607	587	559	522	500	476	423	362	6"
SS6B 57	37	50		643	631	618	597	569	531	509	485	430	369	6"
SS6B 58	37	50		655	642	628	608	578	540	518	493	438	375	6"
SS6B 59	37	50		666	653	639	618	588	550	527	502	446	381	6"
SS6B 60	37	50		677	664	650	629	598	559	536	510	453	388	6"

ELECTRICAL DATA AND DIMENSIONS

MODEL	MOTOR *	ELECTRICAL DATA				HORIZONTAL INSTALLATION	L2 mm	L mm	L1 mm	D mm	D1 mm	TOTAL WEIGHT kg
		P2 NOMINAL		In A	OPERATING BY INVERTER							
		kW	HP									
SS6B 44	6GF	26	35	57	●	●	4161	980	3181	141	167	178
	TR6	26	35	58	○	●	4318	1137	3181	144	167	205
SS6B 45	6GF	26	35	57	●	●	4222	980	3242	141	167	180
	TR6	26	35	58	○	●	4379	1137	3242	144	167	207
SS6B 46	6GF	26	35	57	●	●	4282	980	3302	141	167	181
	TR6	26	35	58	○	●	4439	1137	3302	144	167	208
SS6B 47	6GF	26	35	57	●	●	4343	980	3363	141	167	183
	TR6	26	35	58	○	●	4500	1137	3363	144	167	210
SS6B 48	6GF	26	35	57	●	●	4403	980	3423	141	167	185
	TR6	26	35	58	○	●	4560	1137	3423	144	167	212
SS6B 49	6GF	30	40	61,5	●	●	4535	1051	3484	141	167	198
	TR6	30	40	65	○	●	4676	1192	3484	144	167	219
SS6B 50	6GF	30	40	61,5	●	●	4595	1051	3544	141	167	200
	TR6	30	40	65	○	●	4736	1192	3544	144	167	221
SS6B 51	6GF	30	40	61,5	●	●	4656	1051	3605	141	167	201
	TR6	30	40	65	○	●	4797	1192	3605	144	167	222
SS6B 52	6GF	30	40	61,5	●	●	4716	1051	3665	141	167	203
	TR6	30	40	65	○	●	4857	1192	3665	144	167	224
SS6B 53	6GF	30	40	61,5	●	●	4777	1051	3726	141	167	205
	TR6	30	40	65	○	●	4918	1192	3726	144	167	226
SS6B 54	6GF	30	40	61,5	●	●	4837	1051	3786	141	167	207
	TR6	30	40	65	○	●	4978	1192	3786	144	167	228
SS6B 55	6GF	30	40	61,5	●	●	4898	1051	3847	141	167	209
	TR6	30	40	65	○	●	5039	1192	3847	144	167	230
SS6B 56	6GF	30	40	61,5	●	●	4958	1051	3907	141	167	210
	TR6	30	40	65	○	●	5099	1192	3907	144	167	231
SS6B 57	6GF	37	50	79,3	●	●	5149	1181	3968	141	167	225
	TR6	37	50	80	○	●	5260	1292	3968	144	167	236
SS6B 58	6GF	37	50	79,3	●	●	5209	1181	4028	141	167	227
	TR6	37	50	80	○	●	5320	1292	4028	144	167	238
SS6B 59	6GF	37	50	79,3	●	●	5270	1181	4089	141	167	229
	TR6	37	50	80	○	●	5381	1292	4089	144	167	240
SS6B 60	6GF	37	50	79,3	●	●	5330	1181	4149	141	167	231
	TR6	37	50	80	○	●	5441	1292	4149	144	167	242

* 6GF motor: 6" encapsulated water-glycol-filled motor with stator immersed in thermosetting insulating resin

TR6 motor: 6" water-filled rewindable motor

●	Allowed
○	Only PE2 + PA version

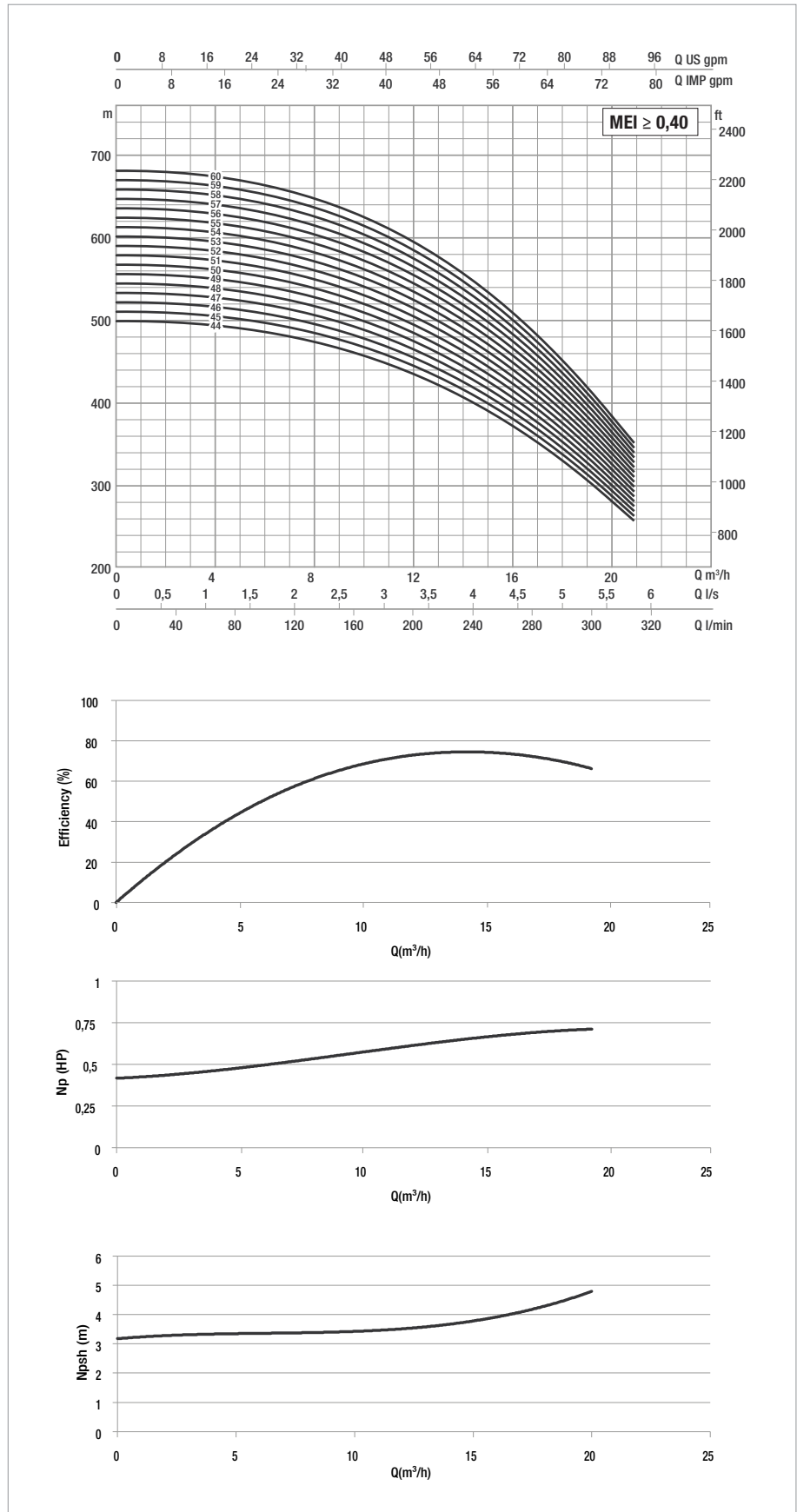
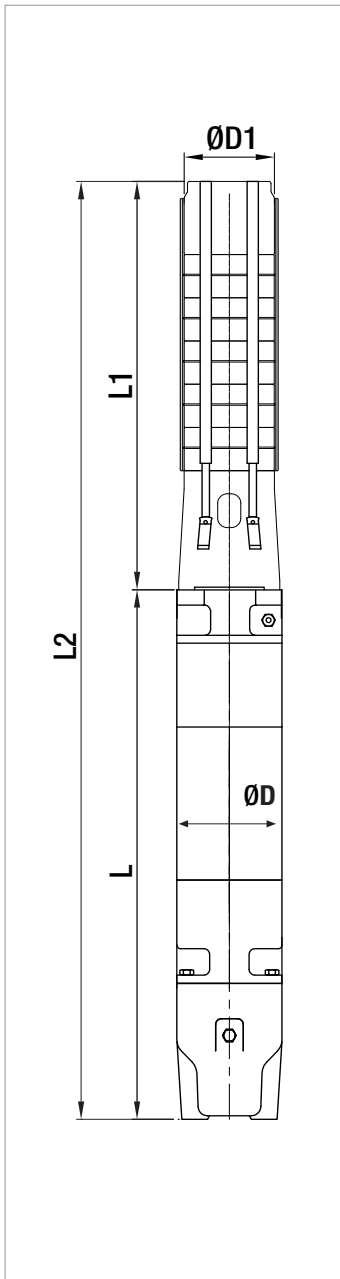

Performance 50 Hz - 2 poles. The performance curves are based on the kinematic viscosity values = $1 \text{ mm}^2/\text{s}$ and density equal to 1000 kg/m^3 . Curve tolerance according to ISO 9906.
For the MEI index, refer to the hydraulic efficiency section

PERFORMANCE 50 HZ - 2 POLES

MODEL	ELECTRICAL DATA		Q=m ³ h Q=l/min	HYDRAULIC DATA										STANDARD MOTOR COUPLING
	P2 NOMINAL			0	6	10	14	18	22	26	30	34	38	
	kW	HP		0	100	166,6	233,3	300	366,6	433,3	500	566,6	633,3	
SS6C 01	1,1	1,5	H (mt)	12	11	11	11	10	9	8	7	6	5	4"
SS6C 02	2,2	3		12	11	11	11	10	9	8	7	6	5	4"
SS6C 03	3	4		35	34	33	32	30	28	25	22	19	15	4"
SS6C 04	4	5,5		47	46	44	43	40	37	34	30	25	20	4" - 6"
SS6C 05	5,5	7,5		59	57	55	53	50	47	42	37	32	25	4" - 6"
SS6C 06	5,5	7,5		70	69	67	64	60	56	51	45	38	30	4" - 6"
SS6C 07	7,5	10		82	80	78	74	70	65	59	52	44	35	4" - 6"
SS6C 08	7,5	10		94	92	89	85	80	75	68	60	51	40	4" - 6"
SS6C 09	9,3	12,5		105	103	100	96	90	84	76	67	57	45	6"
SS6C 10	9,3	12,5		117	114	111	106	100	93	85	75	63	50	6"
SS6C 11	9,3	12,5		129	126	122	117	110	103	93	82	70	55	6"
SS6C 12	11	15		141	137	133	128	120	112	102	90	76	60	6"
SS6C 13	11	15		152	149	144	138	131	121	110	97	82	65	6"
SS6C 14	13	17,5		164	160	155	149	141	131	119	105	89	70	6"
SS6C 15	13	17,5		176	172	166	159	151	140	127	112	95	75	6"
SS6C 16	15	20		187	183	178	170	161	149	136	120	101	80	6"
SS6C 17	15	20		199	195	189	181	171	159	144	127	108	85	6"
SS6C 18	18,5	25		211	206	200	191	181	168	153	135	114	90	6"
SS6C 19	18,5	25		223	217	211	202	191	177	161	142	121	95	6"
SS6C 20	18,5	25		234	229	222	213	201	186	170	150	127	100	6"

ELECTRICAL DATA AND DIMENSIONS

MODEL	MOTOR *	ELECTRICAL DATA				HORIZONTAL INSTALLATION	L2 mm	L mm	L1 mm	D mm	D1 mm	TOTAL WEIGHT kg
		P2 NOMINAL		In A	OPERATING BY INVERTER							
		kW	HP									
SS6C 01	4GG	1,1	1,5	3,2	●	●	650	286	364	93	132	15,6
	4OL	1,1	1,5	3,6	●	●	698	334	364	93	132	14,7
SS6C 02	4GG	2,2	3	5,9	●	●	852	393	459	93	132	23
	4OL	2,2	3	6	●	●	917	458	459	93	132	22,4
SS6C 03	4GG	3	4	8,3	●	●	1098	544	554	93	132	31,5
	4OL	3	4	7,5	●	●	1072	518	554	93	132	26,9
SS6C 04	4GG	4	5,5	10	●	●	1263	614	649	93	132	36,8
	4OL	4	5,5	9,6	●	●	1237	588	649	93	132	30,1
	6GF	4	5,5	10,6	●	●	1250	601	649	141	132	54
SS6C 05	4GG	5,5	7,5	14	●	●	1428	684	744	93	132	42,1
	4OL	5,5	7,5	13,1	●	●	1402	658	744	93	132	38,9
	6GF	5,5	7,5	14	●	●	1375	631	744	141	132	59
	TR6	5,5	7,5	13	○	●	1531	787	744	144	132	65
SS6C 06	4GG	5,5	7,5	14	●	●	1523	684	839	93	132	44,1
	4OL	5,5	7,5	13,1	●	●	1497	658	839	93	132	40,9
	6GF	5,5	7,5	14	●	●	1470	631	839	141	132	61
	TR6	5,5	7,5	13	○	●	1626	787	839	144	132	67
SS6C 07	4GG	7,5	10	17,4	●	●	1698	764	934	93	132	49,8
	4OL	7,5	10	16,9	●	●	1672	738	934	93	132	46,9
	6GF	7,5	10	18	●	●	1595	661	934	141	132	66
	TR6	7,5	10	18	○	●	1751	817	934	144	132	72
SS6C 08	4GG	7,5	10	17,4	●	●	1793	764	1029	93	132	51,8
	4OL	7,5	10	16,9	●	●	1767	738	1029	93	132	48,9
	6GF	7,5	10	18	●	●	1690	661	1029	141	132	68
	TR6	7,5	10	18	○	●	1846	817	1029	144	132	74
SS6C 09	6GF	9,3	12,5	22	●	●	1810	686	1124	141	132	73
	TR6	9,3	12,5	21	○	●	1971	847	1124	144	132	78
SS6C 10	6GF	9,3	12,5	22	●	●	1905	686	1219	141	132	75
	TR6	9,3	12,5	21	○	●	2066	847	1219	144	132	80
SS6C 11	6GF	9,3	12,5	22	●	●	2000	686	1314	141	132	77
	TR6	9,3	12,5	21	○	●	2161	847	1314	144	132	82
SS6C 12	6GF	11	15	25,5	●	●	2140	731	1409	141	132	84
	TR6	11	15	25	○	●	2286	877	1409	144	132	89
SS6C 13	6GF	11	15	25,5	●	●	2235	731	1504	141	132	86
	TR6	11	15	25	○	●	2381	877	1504	144	132	91
SS6C 14	6GF	13	17,5	28,7	●	●	2360	761	1599	141	132	91
	TR6	13	17,5	29	○	●	2506	907	1599	144	132	98
SS6C 15	6GF	13	17,5	28,7	●	●	2455	761	1694	141	132	94
	TR6	13	17,5	29	○	●	2601	907	1694	144	132	101
SS6C 16	6GF	15	20	33,4	●	●	2575	786	1789	141	132	99
	TR6	15	20	32	○	●	2766	977	1789	144	132	115
SS6C 17	6GF	15	20	33,4	●	●	2670	786	1884	141	132	101
	TR6	15	20	32	○	●	2861	977	1884	144	132	117
SS6C 18	6GF	18,5	25	41	●	●	2840	861	1979	141	132	111
	TR6	18,5	25	39	○	●	3016	1037	1979	144	132	122
SS6C 19	6GF	18,5	25	41	●	●	2935	861	2074	141	132	113
	TR6	18,5	25	39	○	●	3111	1037	2074	144	132	124
SS6C 20	6GF	18,5	25	41	●	●	3030	861	2169	141	132	115
	TR6	18,5	25	39	○	●	3206	1037	2169	144	132	126

* **4GG motor:** 4" water-filled motor with stator immersed in thermosetting insulating resin with high heat dissipation capacity
4OL motor: 4" oil-filled rewindable motor

6GF motor: 6" encapsulated water-glycol-filled motor with stator immersed in thermosetting insulating resin
TR6 motor: 6" water-filled rewindable motor

● Allowed
○ Only PE2 + PA version

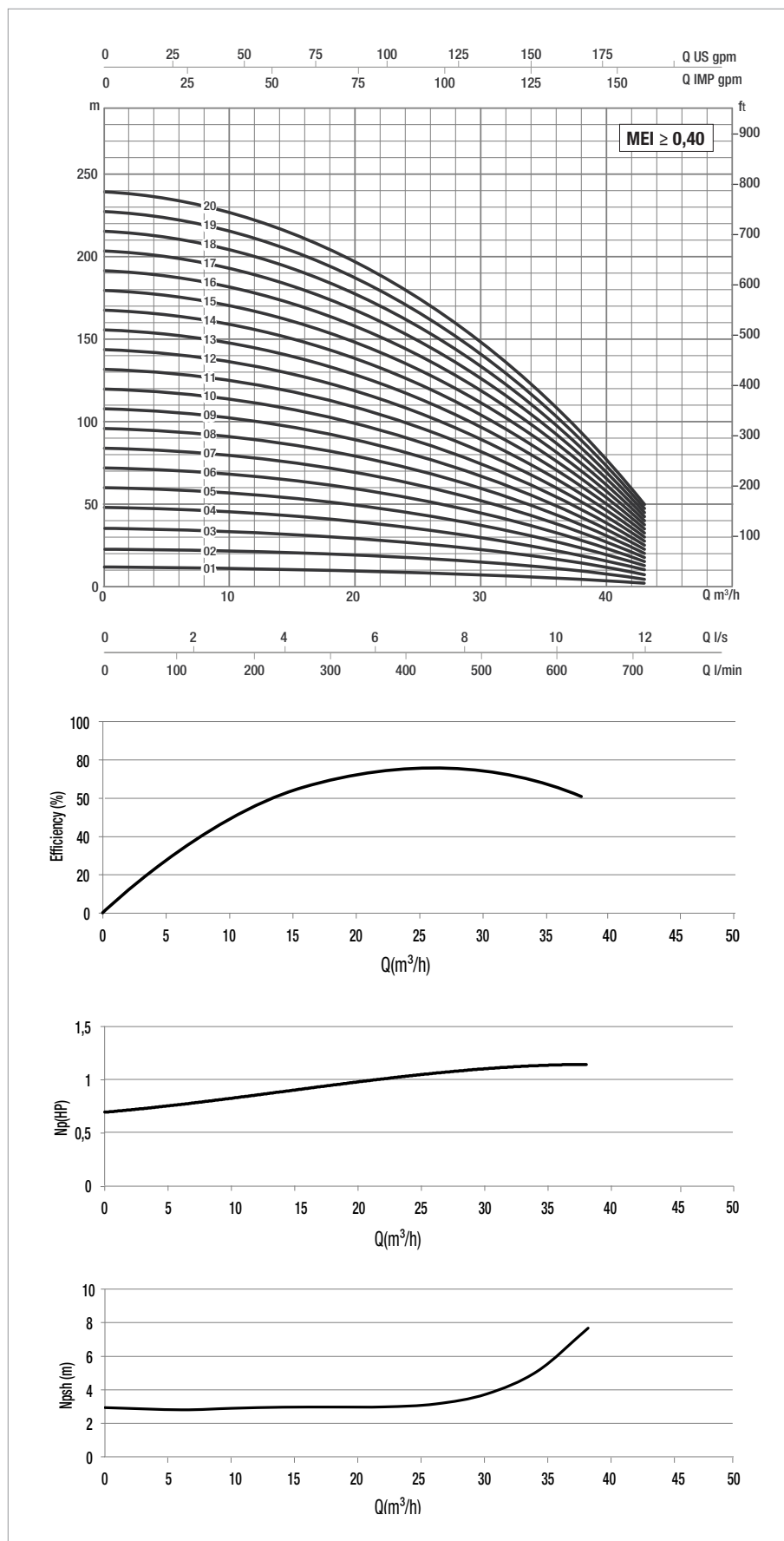
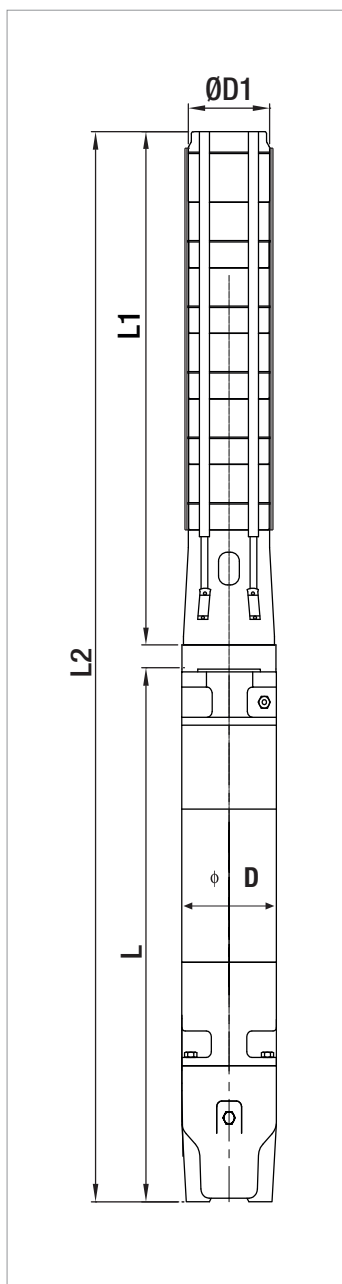

Performance 50 Hz - 2 poles. The performance curves are based on the kinematic viscosity values = $1 \text{ mm}^2/\text{s}$ and density equal to $1000 \text{ kg}/\text{m}^3$. Curve tolerance according to ISO 9906.
For the MEI index, refer to the hydraulic efficiency section

PERFORMANCE 50 HZ - 2 POLES

MODEL	ELECTRICAL DATA		HYDRAULIC DATA										STANDARD MOTOR COUPLING	
	P2 NOMINAL		Q=m³h	0	6	10	14	18	22	26	30	34		38
	kW	HP	Q=l/min	0	100	166,6	233,3	300	366,6	433,3	500	566,6		633,3
SS6C 21	18,5	25	H (m)	246	240	233	223	211	196	178	157	133	105	6"
SS6C 22	22	30		258	252	244	234	221	205	187	165	140	110	6"
SS6C 23	22	30		269	263	255	244	231	214	195	172	146	115	6"
SS6C 24	22	30		281	275	266	255	241	224	203	180	152	120	6"
SS6C 25	22	30		293	286	277	266	251	233	212	187	159	125	6"
SS6C 26	22	30		305	298	289	276	261	242	220	195	165	130	6"
SS6C 27	26	35		316	309	300	287	271	252	229	202	171	136	6"
SS6C 28	26	35		328	320	311	298	281	261	237	210	178	141	6"
SS6C 29	26	35		340	332	322	308	291	270	246	217	184	146	6"
SS6C 30	26	35		351	343	333	319	301	280	254	225	190	151	6"
SS6C 31	30	40		363	355	344	330	311	289	263	232	197	156	6"
SS6C 32	30	40		375	366	355	340	321	298	271	240	203	161	6"
SS6C 33	30	40		387	378	366	351	331	308	280	247	209	166	6"
SS6C 34	30	40		398	389	377	361	341	317	288	255	216	171	6"
SS6C 35	30	40		410	401	388	372	351	326	297	262	222	176	6"
SS6C 36	30	40		422	412	400	383	361	336	305	270	228	181	6"
SS6C 37	37	50		433	423	411	393	371	345	314	277	235	186	6"

ELECTRICAL DATA AND DIMENSIONS

MODEL	MOTOR *	ELECTRICAL DATA				HORIZONTAL INSTALLATION	L2 mm	L mm	L1 mm	D mm	D1 mm	TOTAL WEIGHT kg
		P2 NOMINAL		In A	OPERATING BY INVERTER							
		kW	HP									
SS6C 21	6GF	18,5	25	41	●	●	3125	861	2264	141	132	117
	TR6	18,5	25	39	○	●	3301	1037	2264	144	132	128
SS6C 22	6GF	22	30	47	●	●	3280	921	2359	141	132	124
	TR6	22	30	49	○	●	3426	1067	2359	144	132	145
SS6C 23	6GF	22	30	47	●	●	3375	921	2454	141	132	126
	TR6	22	30	49	○	●	3521	1067	2454	144	132	147
SS6C 24	6GF	22	30	47	●	●	3470	921	2549	141	132	128
	TR6	22	30	49	○	●	3616	1067	2549	144	132	149
SS6C 25	6GF	22	30	47	●	●	3565	921	2644	141	132	130
	TR6	22	30	49	○	●	3711	1067	2644	144	132	151
SS6C 26	6GF	22	30	47	●	●	3660	921	2739	141	132	132
	TR6	22	30	49	○	●	3806	1067	2739	144	132	150
SS6C 27	6GF	26	35	57	●	●	3814	980	2834	141	132	138
	TR6	26	35	58	○	●	3971	1137	2834	144	132	165
SS6C 28	6GF	26	35	57	●	●	3909	980	2929	141	132	141
	TR6	26	35	58	○	●	4066	1137	2929	144	132	168
SS6C 29	6GF	26	35	57	●	●	4004	980	3024	141	132	143
	TR6	26	35	58	○	●	4161	1137	3024	144	132	170
SS6C 30	6GF	26	35	57	●	●	4099	980	3119	141	132	145
	TR6	26	35	58	○	●	4256	1137	3119	141	132	172
SS6C 31	6GF	30	40	61,5	●	●	4265	1051	3214	141	132	158
	TR6	30	40	65	○	●	4406	1192	3214	144	132	179
SS6C 32	6GF	30	40	61,5	●	●	4360	1051	3309	141	132	160
	TR6	30	40	65	○	●	4501	1192	3309	144	132	181
SS6C 33	6GF	30	40	61,5	●	●	4455	1051	3404	141	132	162
	TR6	30	40	65	○	●	4596	1192	3404	144	132	183
SS6C 34	6GF	30	40	61,5	●	●	4550	1051	3499	141	132	164
	TR6	30	40	65	○	●	4691	1192	3499	144	132	185
SS6C 35	6GF	30	40	61,5	●	●	4645	1051	3594	141	132	166
	TR6	30	40	65	○	●	4786	1192	3594	144	132	187
SS6C 36	6GF	30	40	61,5	●	●	4740	1051	3689	141	132	168
	TR6	30	40	65	○	●	4881	1192	3689	144	132	189
SS6C 37	6GF	37	50	79,3	●	●	4965	1181	3784	141	132	183
	TR6	37	50	80	○	●	5076	1292	3784	144	132	194

* **6GF motor:** 6" encapsulated water-glycol-filled motor with stator immersed in thermosetting insulating resin
TR6 motor: 6" water-filled rewindable motor

●	Allowed
○	Only PE2 + PA version

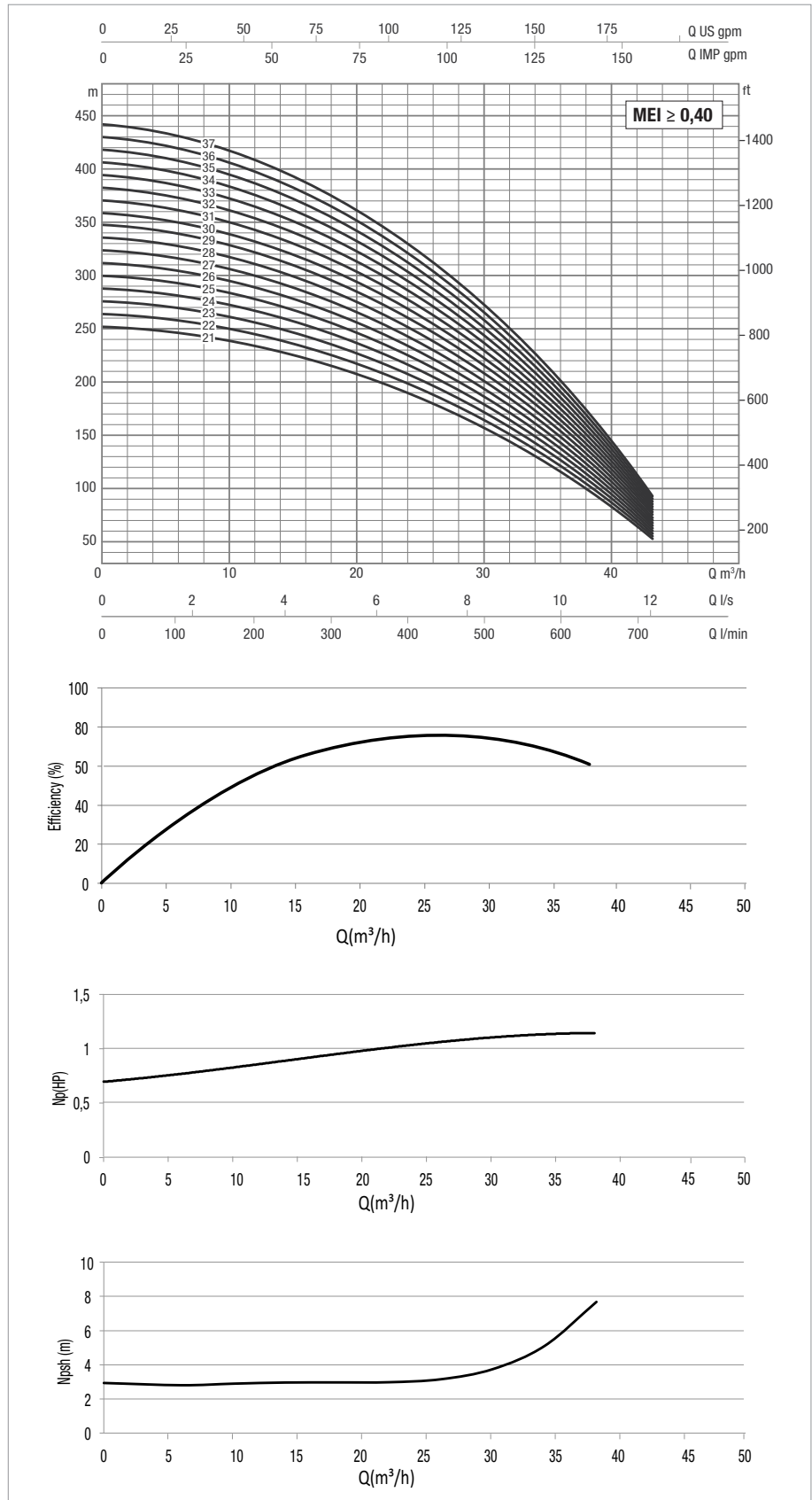
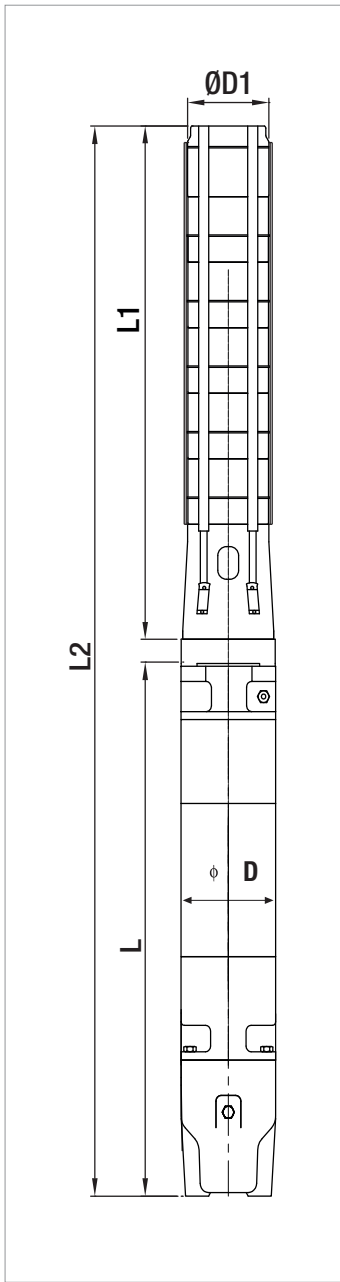

Performance 50 Hz - 2 poles. The performance curves are based on the kinematic viscosity values = $1 \text{ mm}^2/\text{s}$ and density equal to $1000 \text{ kg}/\text{m}^3$. Curve tolerance according to ISO 9906.
For the MEI index, refer to the hydraulic efficiency section

PERFORMANCE 50 HZ - 2 POLES

MODEL	ELECTRICAL DATA		HYDRAULIC DATA											STANDARD MOTOR COUPLING
	P2 NOMINAL		Q=m³h	0	6	10	14	18	22	26	30	34	38	
	kW	HP	Q=l/min	0	100	166,6	233,3	300	366,6	433,3	500	566,6	633,3	
SS6C 38	37	50	H (m)	445	435	422	404	381	354	322	285	241	191	6"
SS6C 39	37	50		457	446	433	415	392	364	331	292	247	196	6"
SS6C 40	37	50		469	458	444	425	402	373	339	300	254	201	6"
SS6C 41	37	50		480	469	455	436	412	382	348	307	260	206	6"
SS6C 42	37	50		492	481	466	446	422	392	356	315	266	211	6"
SS6C 43	45	60		504	492	477	457	432	401	365	322	273	216	8"
SS6C 44	45	60		515	504	488	468	442	410	373	330	279	221	8"
SS6C 45	45	60		527	515	499	478	452	420	381	337	285	226	8"
SS6C 46	45	60		539	526	511	489	462	429	390	344	292	231	8"
SS6C 47	45	60		551	538	522	500	472	438	398	352	298	236	8"
SS6C 48	45	60		562	549	533	510	482	448	407	359	304	241	8"
SS6C 49	45	60		574	561	544	521	492	457	415	367	311	246	8"
SS6C 50	45	60		586	572	555	532	502	466	424	374	317	251	8"
SS6C 51	45	60		597	584	566	542	512	476	432	382	323	256	8"
SS6C 52	55	75		609	595	577	553	522	485	441	389	330	261	8"
SS6C 53	55	75		621	607	588	563	532	494	449	397	336	266	8"
SS6C 54	55	75		633	618	599	574	542	503	458	404	342	271	8"

ELECTRICAL DATA AND DIMENSIONS

MODEL	MOTOR *	ELECTRICAL DATA				HORIZONTAL INSTALLATION	L2 mm	L mm	L1 mm	D mm	D1 mm	TOTAL WEIGHT kg
		P2 NOMINAL		In A	OPERATING BY INVERTER							
		kW	HP									
SS6C 38	6GF	37	50	79,3	●	●	5060	1181	3879	141	132	185
	TR6	37	50	80	○	●	5171	1292	3879	144	132	196
SS6C 39	6GF	37	50	79,3	●	●	5405	1181	4224	141	167	226
	TR6	37	50	80	○	●	5516	1292	4224	144	167	237
SS6C 40	6GF	37	50	79,3	●	●	5500	1181	4319	141	167	228
	TR6	37	50	80	○	●	5611	1292	4319	144	167	239
SS6C 41	6GF	37	50	79,3	●	●	5595	1181	4414	141	167	231
	TR6	37	50	80	○	●	5706	1292	4414	144	167	242
SS6C 42	6GF	37	50	79,3	●	●	5690	1181	4509	141	167	234
	TR6	37	50	80	○	●	5801	1292	4509	144	167	245
SS6C 43	TR8	45	60	92	○	●	5874	1270	4604	192	167	311
SS6C 44	TR8	45	60	92	○	●	5969	1270	4699	192	167	314
SS6C 45	TR8	45	60	92	○	●	6064	1270	4794	192	167	316
SS6C 46	TR8	45	60	92	○	●	6159	1270	4889	192	167	319
SS6C 47	TR8	45	60	92	○	●	6254	1270	4984	192	167	322
SS6C 48	TR8	45	60	92	○	●	6349	1270	5079	192	167	324
SS6C 49	TR8	45	60	92	○	●	6444	1270	5174	192	167	327
SS6C 50	TR8	45	60	92	○	●	6539	1270	5269	192	167	329
SS6C 51	TR8	45	60	92	○	●	6634	1270	5364	192	167	332
SS6C 52	TR8	55	75	109	○	●	6809	1350	5459	192	167	350
SS6C 53	TR8	55	75	109	○	●	6904	1350	5554	192	167	352
SS6C 54	TR8	55	75	109	○	●	6999	1350	5649	192	167	355

* **6GF motor:** 6" encapsulated water-glycol-filled motor with stator immersed in thermosetting insulating resin
TR motor: 6-8" water-filled rewindable motor

●	Allowed
○	Only PE2 + PA version

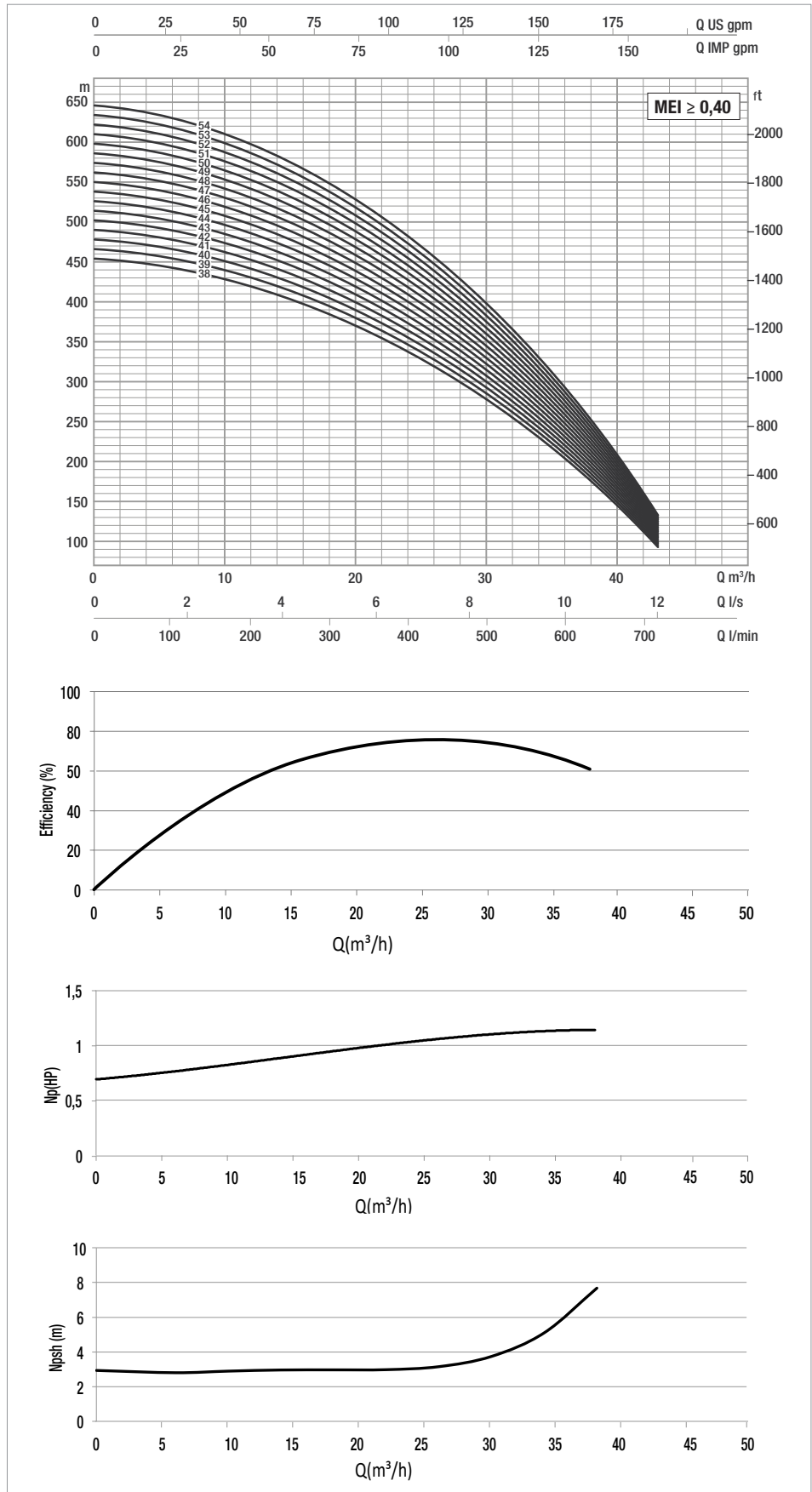
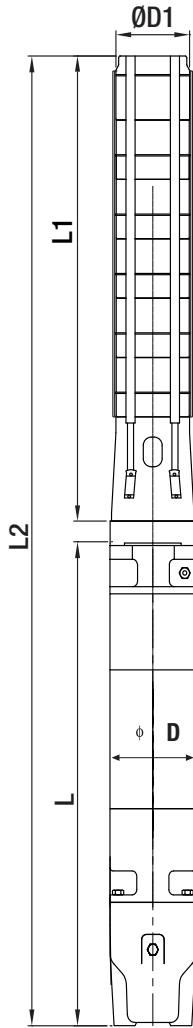

PERFORMANCE 50 HZ - 2 POLES

MODEL	ELECTRICAL DATA		Q=m ³ h Q=l/min	HYDRAULIC DATA										STANDARD MOTOR COUPLING
	P2 NOMINAL			0	20	25	30	35	40	45	50	55	60	
	kW	HP		0	333,3	416,6	500	583,3	666,6	750	833,3	916,6	1000	
SS6D 01	2,2	3	H (mt)	14	13	12	11	10	10	9	8	7	5	4"
SS6D 02	4	5,5		28	25	24	22	21	19	18	16	14	10	4" - 6"
SS6D 03	5,5	7,5		42	38	36	33	31	29	26	24	20	16	4" - 6"
SS6D 04	7,5	10		56	50	47	44	41	38	35	32	27	21	4" - 6"
SS6D 05	7,5	10		70	63	59	56	52	48	44	39	34	26	4" - 6"
SS6D 06	9,3	12,5		84	75	71	67	62	57	53	47	41	31	6"
SS6D 07	11	15		98	88	83	78	72	67	61	55	57	36	6"
SS6D 08	13	17,5		112	101	95	89	83	77	70	63	54	42	6"
SS6D 09	15	20		126	113	107	100	93	86	79	71	61	47	6"
SS6D 10	18,5	25		140	126	119	111	103	96	88	79	68	52	6"
SS6D 11	18,5	25		154	138	130	122	114	105	97	87	74	57	6"
SS6D 12	22	30		168	151	142	133	124	115	105	95	81	62	6"
SS6D 13	22	30		182	163	154	144	134	125	114	102	88	68	6"
SS6D 14	22	30		196	176	166	155	145	134	123	110	95	73	6"
SS6D 15	26	35		210	188	178	167	155	144	132	118	101	78	6"
SS6D 16	26	35		224	201	190	178	165	153	141	126	108	83	6"
SS6D 17	30	40		238	214	202	189	176	163	149	134	115	88	6"
SS6D 18	30	40		252	226	213	200	186	172	158	142	122	93	6"
SS6D 19	37	50		266	239	225	211	197	182	167	150	128	99	6"

ELECTRICAL DATA AND DIMENSIONS

MODEL	MOTOR *	ELECTRICAL DATA				HORIZONTAL INSTALLATION	L2 mm	L mm	L1 mm	D mm	D1 mm	TOTAL WEIGHT kg
		P2 NOMINAL		In A	OPERATING BY INVERTER							
		kW	HP									
SS6D 01	4GG	2,2	3	5,9	●	●	775	393	382	93	144	21
	40L	2,2	3	6	●	●	840	458	382	93	144	20,4
SS6D 02	4GG	4	5,5	10	●	●	1108	614	494	93	144	33,8
	40L	4	5,5	9,6	●	●	1082	588	494	93	144	27,1
	6GF	4	5,5	10,6	●	●	1095	601	494	141	144	51
SS6D 03	4GG	5,5	7,5	14	●	●	1290	684	606	93	144	39,1
	40L	5,5	7,5	13,1	●	●	1264	658	606	93	144	35,9
	6GF	5,5	7,5	14	●	●	1237	631	606	141	144	56
	TR6	5,5	7,5	13	○	●	1393	787	606	144	144	62
SS6D 04	4GG	7,5	10	17,4	●	●	1482	764	718	93	144	45,8
	40L	7,5	10	16,9	●	●	1456	738	718	93	144	42,9
	6GF	7,5	10	18	●	●	1379	661	718	141	144	62
	TR6	7,5	10	18	○	●	1535	817	718	144	144	68
SS6D 05	4GG	7,5	10	17,4	●	●	1594	764	830	93	144	48,8
	40L	7,5	10	16,9	●	●	1568	738	830	93	144	45,9
	6GF	7,5	10	18	●	●	1491	661	830	141	144	65
	TR6	7,5	10	18	○	●	1647	817	830	144	144	71
SS6D 06	6GF	9,3	12,5	22	●	●	1628	686	942	141	144	70
	TR6	9,3	12,5	21	○	●	1789	847	942	144	144	75
SS6D 07	6GF	11	15	25,5	●	●	1785	731	1054	141	144	78
	TR6	11	15	25	○	●	1931	877	1054	144	144	83
SS6D 08	6GF	13	17,5	28,7	●	●	1927	761	1166	141	144	84
	TR6	13	17,5	29	○	●	2073	907	1166	144	144	89
SS6D 09	6GF	15	20	33,4	●	●	2064	786	1278	141	144	89
	TR6	15	20	32	○	●	2255	977	1278	144	144	105
SS6D 10	6GF	18,5	25	41	●	●	2251	861	1390	141	144	100
	TR6	18,5	25	39	○	●	2427	1037	1390	144	144	111
SS6D 11	6GF	18,5	25	41	●	●	2363	861	1502	141	144	103
	TR6	18,5	25	39	○	●	2539	1037	1502	144	144	114
SS6D 12	6GF	22	30	47	●	●	2535	921	1614	141	144	110
	TR6	22	30	49	○	●	2681	1067	1614	144	144	131
SS6D 13	6GF	22	30	47	●	●	2647	921	1726	141	144	113
	TR6	22	30	49	○	●	2793	1067	1726	144	144	134
SS6D 14	6GF	22	30	47	●	●	2759	921	1838	141	144	116
	TR6	22	30	49	○	●	2905	1067	1838	144	144	137
SS6D 15	6GF	26	35	57	●	●	2930	980	1950	141	144	122
	TR6	26	35	58	○	●	3087	1137	1950	144	144	147
SS6D 16	6GF	26	35	57	●	●	3042	980	2062	141	144	125
	TR6	26	35	58	○	●	3199	1137	2062	144	144	150
SS6D 17	6GF	30	40	61,5	●	●	3225	1051	2174	141	144	138
	TR6	30	40	65	○	●	3366	1192	2174	144	144	159
SS6D 18	6GF	30	40	61,5	●	●	3337	1051	2286	141	144	141
	TR6	30	40	65	○	●	3478	1192	2286	144	144	162
SS6D 19	6GF	37	50	79,3	●	●	3579	1181	2398	141	144	157
	TR6	37	50	80	○	●	3690	1292	2398	144	144	168

* **4GG motor:** 4" water-filled motor with stator immersed in thermosetting insulating resin with high heat dissipation capacity
40L motor: 4" oil-filled rewindable motor

6GF motor: 6" encapsulated water-glycol-filled motor with stator immersed in thermosetting insulating resin
TR6 motor: 6" water-filled rewindable motor

● Allowed
○ Only PE2 + PA version

SS6D

SUBMERSIBLE PUMPS

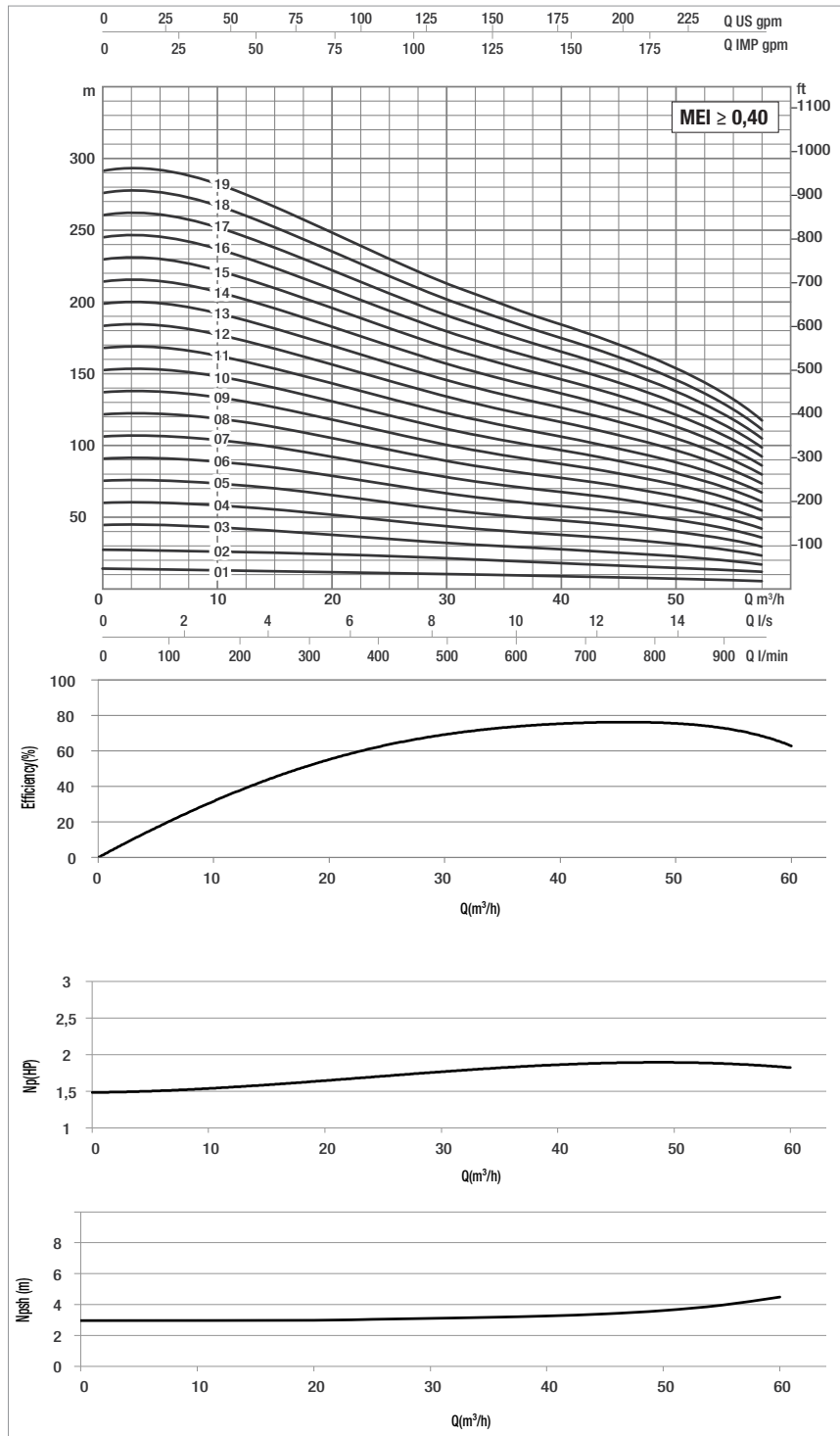
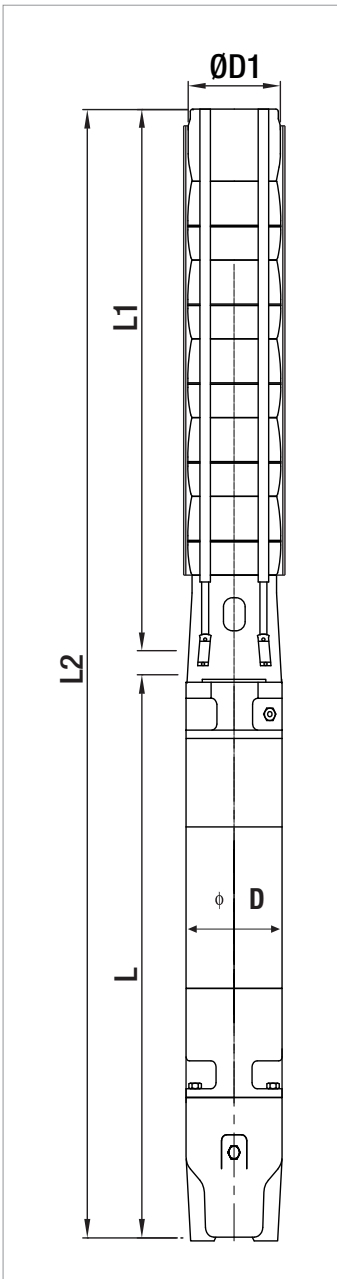

Performance 50 Hz - 2 poles. The performance curves are based on the kinematic viscosity values = 1 mm²/s and density equal to 1000 kg/m³. Curve tolerance according to ISO 9906.
For the MEI index, refer to the hydraulic efficiency section

PERFORMANCE 50 HZ - 2 POLES

MODEL	ELECTRICAL DATA		HYDRAULIC DATA											STANDARD MOTOR COUPLING
	P2 NOMINAL		Q=m³h	0	20	25	30	35	40	45	50	55	60	
	kW	HP	Q=l/min	0	333,3	416,6	500	583,3	666,6	750	833,3	916,6	1000	
SS6D 20	37	50	H (mt)	280	251	237	222	207	192	176	158	135	104	6"
SS6D 21	37	50		294	264	249	233	217	201	184	166	142	109	6"
SS6D 22	37	50		308	276	261	244	228	211	193	173	149	114	6"
SS6D 23	37	50		322	289	273	255	238	220	202	181	155	119	6"
SS6D 24	45	60		336	302	285	267	248	230	211	189	162	125	8"
SS6D 25	45	60		350	314	296	278	259	239	220	197	169	130	8"
SS6D 26	45	60		364	327	308	289	269	249	228	205	176	135	8"
SS6D 27	45	60		378	339	320	300	279	259	237	213	182	140	8"
SS6D 28	45	60		392	352	332	311	290	268	246	221	189	145	8"
SS6D 29	45	60		406	364	344	322	300	278	255	229	196	151	8"
SS6D 30	45	60		420	377	356	333	310	287	264	237	203	156	8"
SS6D 31	55	75		434	390	368	344	321	297	272	244	209	161	8"
SS6D 32	55	75		448	402	379	355	331	307	281	252	216	166	8"
SS6D 33	55	75		462	415	391	366	341	316	290	260	223	171	8"

ELECTRICAL DATA AND DIMENSIONS

MODEL	MOTOR *	ELECTRICAL DATA				HORIZONTAL INSTALLATION	L2 mm	L mm	L1 mm	D mm	D1 mm	TOTAL WEIGHT kg
		P2 NOMINAL		In A	OPERATING BY INVERTER							
		kW	HP									
SS6D 20	6GF	37	50	79,3	●	●	3691	1181	2510	141	144	159
	TR6	37	50	80	○	●	3802	1292	2510	144	144	170
SS6D 21	6GF	37	50	79,3	●	●	3803	1181	2622	141	144	162
	TR6	37	50	80	○	●	3914	1292	2622	144	144	173
SS6D 22	6GF	37	50	79,3	●	●	3915	1181	2734	141	144	165
	TR6	37	50	80	○	●	4026	1292	2734	144	144	176
SS6D 23	6GF	37	50	79,3	●	●	4027	1181	2846	141	144	167
	TR6	37	50	80	○	●	4138	1292	2846	144	144	178
SS6D 24	TR8	45	60	92	○	●	4228	1270	2958	192	144	245
SS6D 25	TR8	45	60	92	○	●	4340	1270	3070	192	144	248
SS6D 26	TR8	45	60	92	○	●	4452	1270	3182	192	144	250
SS6D 27	TR8	45	60	92	○	●	4564	1270	3294	192	144	253
SS6D 28	TR8	45	60	92	○	●	4676	1270	3406	192	144	256
SS6D 29	TR8	45	60	92	○	●	4788	1270	3518	192	144	258
SS6D 30	TR8	45	60	92	○	●	4900	1270	3630	192	144	261
SS6D 31	TR8	55	75	109	○	●	5092	1350	3742	192	144	278
SS6D 32	TR8	55	75	109	○	●	5204	1350	3854	192	144	281
SS6D 33	TR8	55	75	109	○	●	5316	1350	3966	192	144	284

* **6GF motor:** 6" encapsulated water-glycol-filled motor with stator immersed in thermosetting insulating resin
TR motor: 6-8" water-filled rewindable motor

●	Allowed
○	Only PE2 + PA version

SS6D

SUBMERSIBLE PUMPS

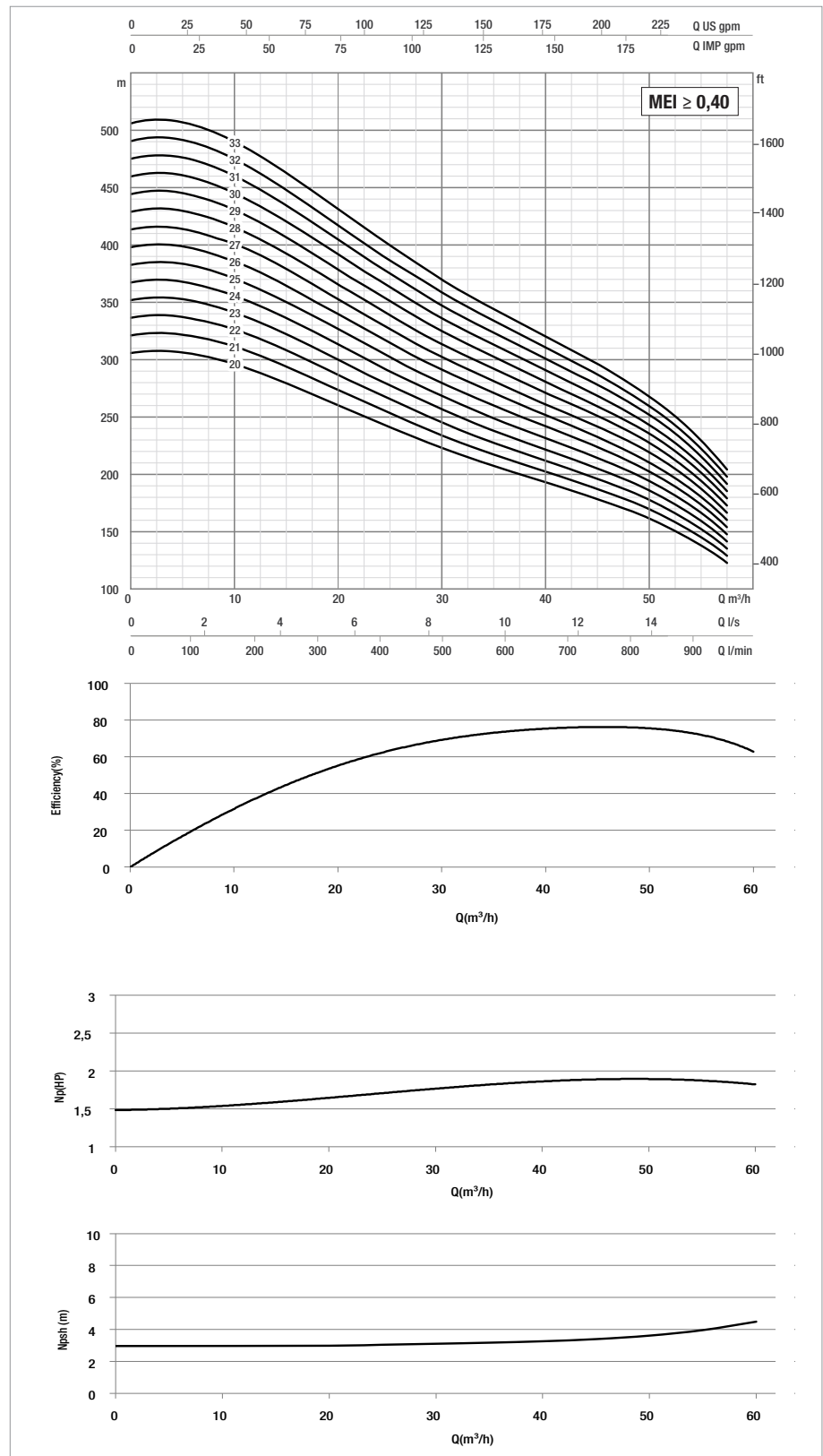
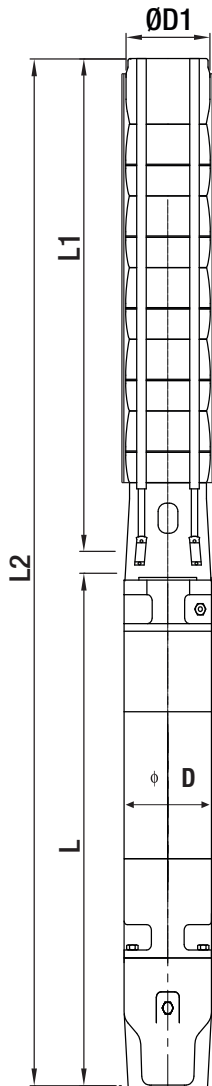

PERFORMANCE 50 HZ - 2 POLES

MODEL	ELECTRICAL DATA		Q=m ³ h Q=l/min	HYDRAULIC DATA										STANDARD MOTOR COUPLING
	P2 NOMINAL			0	20	40	45	50	55	60	65	70	75	
	kW	HP		0	333,3	666,6	750	833,3	916,6	1000	1083,3	1166,6	1250	
SS6E 01	2,2	3	H (mt)	15	13	10	10	9	9	8	8	7	6	4"
SS6E 02	4	5,5		30	26	21	20	19	18	17	15	14	11	4" - 6"
SS6E 03	5,5	7,5		45	38	31	30	28	27	25	23	20	17	4" - 6"
SS6E 04	7,5	10		60	51	42	40	38	36	33	31	27	23	4" - 6"
SS6E 05	9,3	12,5		75	64	52	50	47	45	42	38	34	28	6"
SS6E 06	11	15		90	77	62	59	57	54	50	46	41	34	6"
SS6E 07	13	17,5		105	90	73	69	66	63	59	54	48	40	6"
SS6E 08	15	20		120	103	83	79	75	71	67	61	54	45	6"
SS6E 09	18,5	25		135	115	94	89	85	80	75	69	61	51	6"
SS6E 10	18,5	25		150	128	104	99	94	89	84	77	68	56	6"
SS6E 11	22	30		165	141	115	109	104	98	92	85	75	62	6"
SS6E 12	22	30		180	154	125	119	113	107	100	92	82	68	6"
SS6E 13	26	35		195	167	135	129	123	116	109	100	88	73	6"
SS6E 14	26	35		210	180	146	139	132	125	117	108	95	79	6"
SS6E 15	30	40		225	192	156	149	141	134	126	115	102	85	6"
SS6E 16	30	40		240	205	167	159	151	143	134	123	109	90	6"
SS6E 17	30	40		255	218	177	169	160	152	142	131	116	96	6"

ELECTRICAL DATA AND DIMENSIONS

MODEL	MOTOR *	ELECTRICAL DATA				HORIZONTAL INSTALLATION	L2 mm	L mm	L1 mm	D mm	D1 mm	TOTAL WEIGHT kg
		P2 NOMINAL		In A	OPERATING BY INVERTER							
		kW	HP									
SS6E 01	4GG	2,2	3	5,9	●	●	775	393	382	93	144	21
	40L	2,2	3	6	●	●	840	458	382	93	144	20,4
SS6E 02	4GG	4	5,5	10	●	●	1108	614	494	93	144	33,8
	40L	4	5,5	9,6	●	●	1082	588	494	93	144	27,1
	6GF	4	5,5	10,6	●	●	1095	601	494	141	144	51
SS6E 03	4GG	5,5	7,5	14	●	●	1290	684	606	93	144	39,1
	40L	5,5	7,5	13,1	●	●	1264	658	606	93	144	35,9
	6GF	5,5	7,5	14	●	●	1237	631	606	141	144	56
	TR6	5,5	7,5	13	○	●	1393	787	606	144	144	62
SS6E 04	4GG	7,5	10	17,4	●	●	1482	764	718	93	144	45,8
	40L	7,5	10	16,9	●	●	1456	738	718	93	144	42,9
	6GF	7,5	10	18	●	●	1379	661	718	141	144	62
	TR6	7,5	10	18	○	●	1535	817	718	144	144	68
SS6E 05	6GF	9,3	12,5	22	○	●	1516	686	830	141	144	68
	TR6	9,3	12,5	21	●	●	1677	847	830	144	144	73
SS6E 06	6GF	11	15	25,5	○	●	1673	731	942	141	144	75
	TR6	11	15	25	●	●	1819	877	942	144	144	80
SS6E 07	6GF	13	17,5	28,7	○	●	1815	761	1054	141	144	81
	TR6	13	17,5	29	●	●	1961	907	1054	144	144	86
SS6E 08	6GF	15	20	33,4	○	●	1952	786	1166	141	144	87
	TR6	15	20	32	●	●	2143	977	1166	144	144	103
SS6E 09	6GF	18,5	25	41	○	●	2139	861	1278	141	144	97
	TR6	18,5	25	39	●	●	2315	1037	1278	144	144	108
SS6E 10	6GF	18,5	25	41	○	●	2251	861	1390	141	144	100
	TR6	18,5	25	39	●	●	2427	1037	1390	144	144	111
SS6E 11	6GF	22	30	47	○	●	2423	921	1502	141	144	108
	TR6	22	30	49	●	●	2569	1067	1502	144	144	129
SS6E 12	6GF	22	30	47	○	●	2535	921	1614	141	144	110
	TR6	22	30	49	●	●	2681	1067	1614	144	144	131
SS6E 13	6GF	26	35	57	○	●	2706	980	1726	141	144	117
	TR6	26	35	58	●	●	2863	1137	1726	144	144	142
SS6E 14	6GF	26	35	57	○	●	2818	980	1838	141	144	120
	TR6	26	35	58	●	●	2975	1137	1838	144	144	145
SS6E 15	6GF	30	40	61,5	○	●	3001	1051	1950	141	144	133
	TR6	30	40	65	●	●	3142	1192	1950	144	144	154
SS6E 16	6GF	30	40	61,5	○	●	3113	1051	2062	141	144	136
	TR6	30	40	65	●	●	3254	1192	2062	144	144	157
SS6E 17	6GF	30	40	61,5	○	●	3225	1051	2174	141	144	139
	TR6	30	40	65	●	●	3366	1192	2174	144	144	160

* **6GF motor:** 6" encapsulated water-glycol-filled motor with stator immersed in thermosetting insulating resin
TR6 motor: 6" water-filled rewindable motor

●	Allowed
○	Only PE2 + PA version

SS6E

SUBMERSIBLE PUMPS

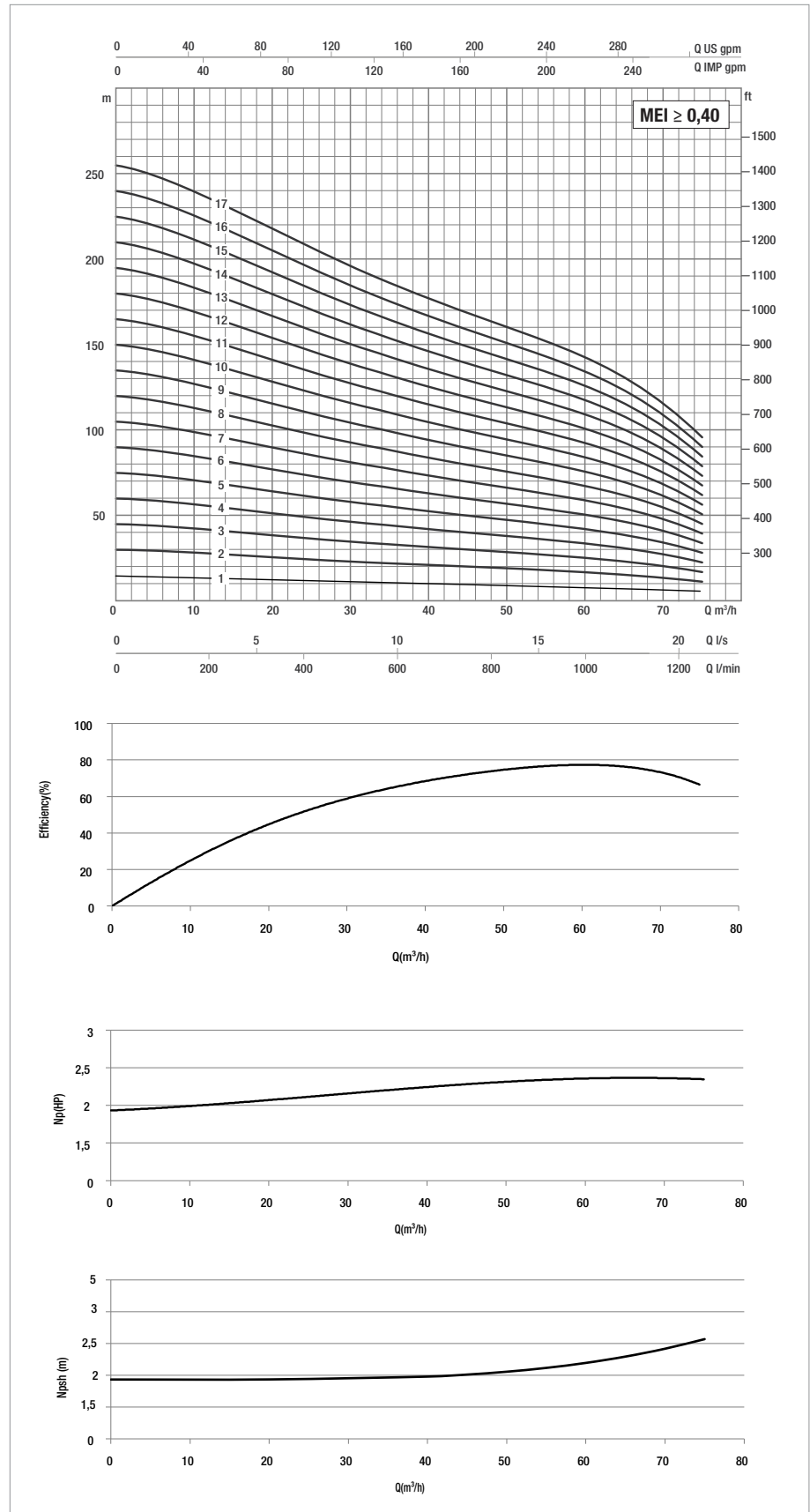
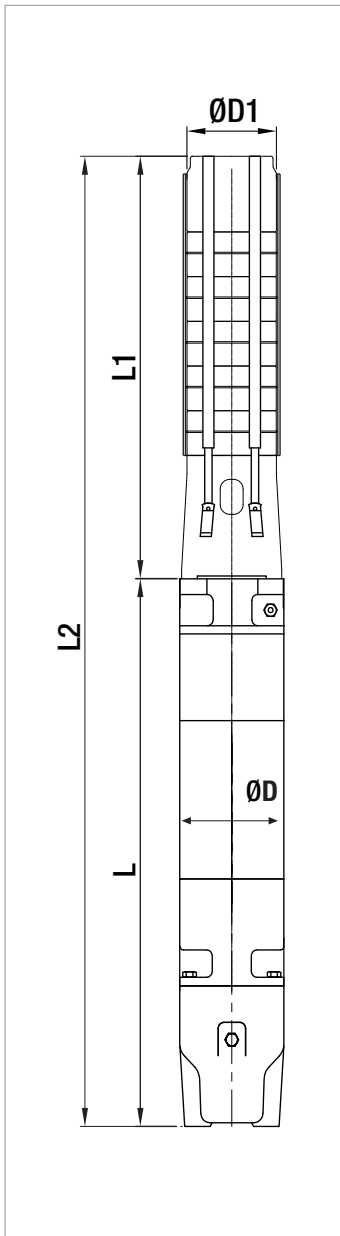

Performance 50 Hz - 2 poles. The performance curves are based on the kinematic viscosity values = $1 \text{ mm}^2/\text{s}$ and density equal to $1000 \text{ kg}/\text{m}^3$. Curve tolerance according to ISO 9906.
For the MEI index, refer to the hydraulic efficiency section

PERFORMANCE 50 HZ - 2 POLES

MODEL	ELECTRICAL DATA		HYDRAULIC DATA											STANDARD MOTOR COUPLING
	P2 NOMINAL		Q=m ³ h	0	20	40	45	50	55	60	65	70	75	
	kW	HP	Q=l/min	0	333,3	666,6	750	833,3	916,6	1000	1083,3	1166,6	1250	
SS6E 18	37	50	H (mt)	270	231	187	178	170	161	151	138	122	102	6"
SS6E 19	37	50		285	244	198	188	179	170	159	146	129	107	6"
SS6E 20	37	50		300	257	208	198	189	179	167	154	136	113	6"
SS6E 21	37	50		315	269	219	208	198	188	176	161	143	119	6"
SS6E 22	45	60		330	282	229	218	207	197	184	169	150	124	8"
SS6E 23	45	60		345	295	239	228	217	205	193	177	157	130	8"
SS6E 24	45	60		360	308	250	238	226	214	201	184	163	135	8"
SS6E 25	55	75		375	321	260	248	236	223	209	192	170	141	8"
SS6E 26	55	75		390	334	271	258	245	232	218	200	177	147	8"
SS6E 27	55	75		405	346	281	268	255	241	226	208	184	152	8"
SS6E 28	55	75		420	359	292	278	264	250	234	215	191	158	8"
SS6E 29	55	75		435	372	302	287	273	259	243	223	197	164	8"
SS6E 30	55	75		450	385	312	297	283	268	251	231	204	169	8"

ELECTRICAL DATA AND DIMENSIONS

MODEL	MOTOR *	ELECTRICAL DATA				HORIZONTAL INSTALLATION	L2 mm	L mm	L1 mm	D mm	D1 mm	TOTAL WEIGHT kg
		P2 NOMINAL		In A	OPERATING BY INVERTER							
		kW	HP									
SS6E 18	6GF	37	50	79,3	○	●	3467	1181	2286	141	144	154
	TR6	37	50	80	●	●	3578	1292	2286	144	144	165
SS6E 19	6GF	37	50	79,3	○	●	3579	1181	2398	141	144	157
	TR6	37	50	80	●	●	3690	1292	2398	144	144	168
SS6E 20	6GF	37	50	79,3	○	●	3691	1181	2510	141	144	160
	TR6	37	50	80	●	●	3802	1292	2510	144	144	171
SS6E 21	6GF	37	50	79,3	○	●	3803	1181	2622	141	144	162
	TR6	37	50	80	●	●	3914	1292	2622	144	144	173
SS6E 22	TR8	45	60	92	○	●	4004	1270	2734	192	144	240
SS6E 23	TR8	45	60	92	○	●	4116	1270	2846	192	144	242
SS6E 24	TR8	45	60	92	○	●	4228	1270	2958	192	144	245
SS6E 25	TR8	55	75	109	○	●	4420	1350	3070	192	144	263
SS6E 26	TR8	55	75	109	○	●	4532	1350	3182	192	144	265
SS6E 27	TR8	55	75	109	○	●	4644	1350	3294	192	144	268
SS6E 28	TR8	55	75	109	○	●	4756	1350	3406	192	144	271
SS6E 29	TR8	55	75	109	○	●	4868	1350	3518	192	144	273
SS6E 30	TR8	55	75	109	○	●	4980	1350	3630	192	144	276

* **6GF motor:** 6" encapsulated water-glycol-filled motor with stator immersed in thermosetting insulating resin
TR motor: 6-8" water-filled rewindable motor

●	Allowed
○	Only PE2 + PA version

SS6E

SUBMERSIBLE PUMPS

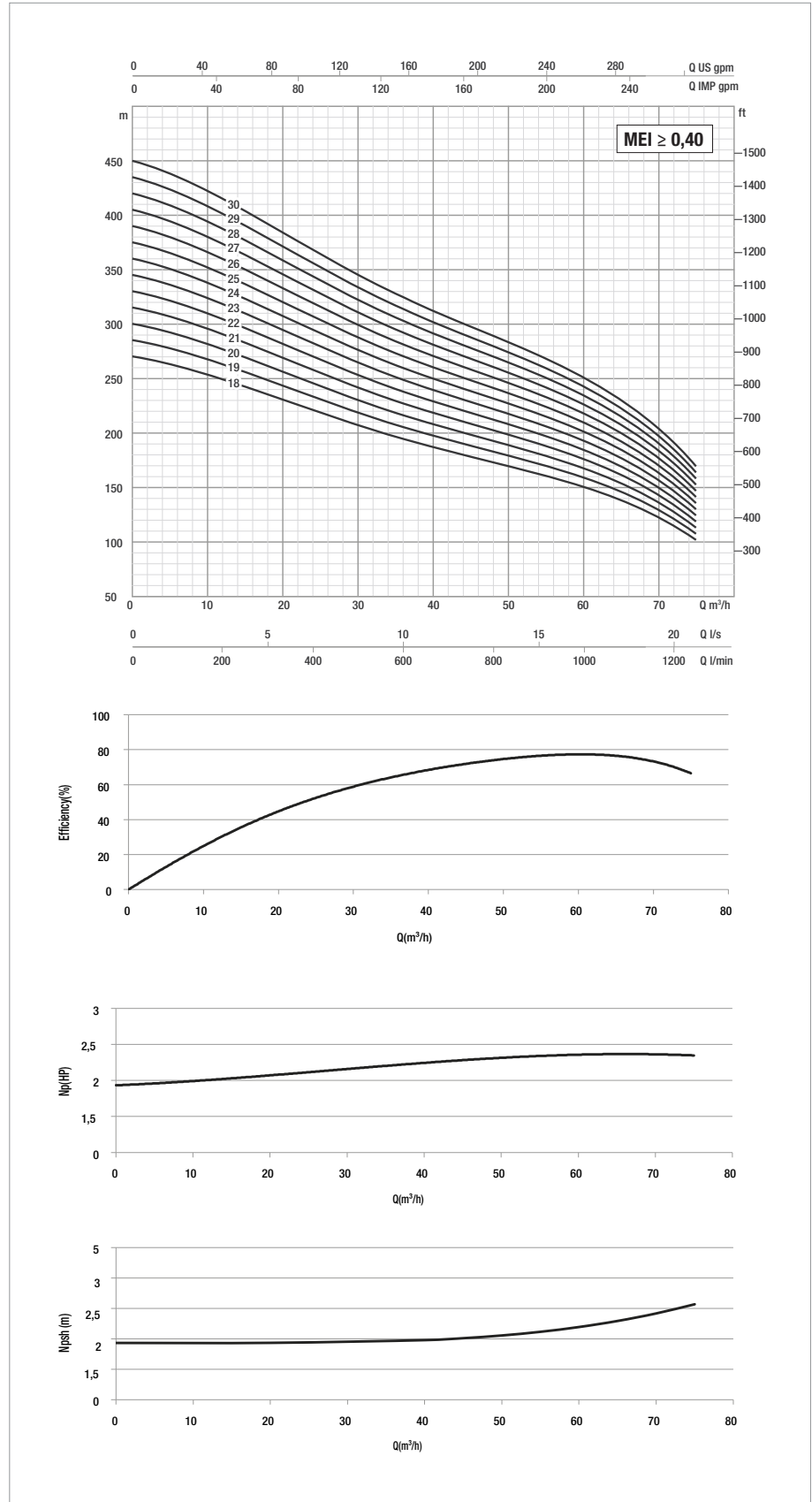
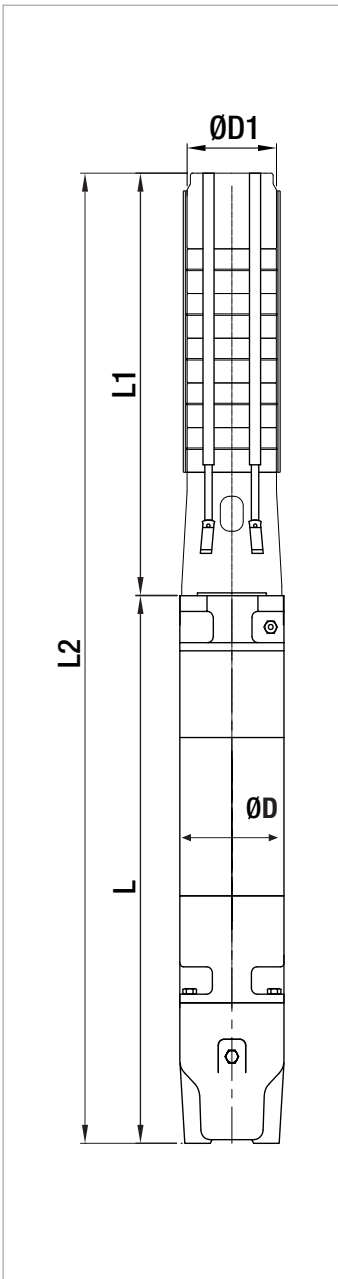

Performance 50 Hz - 2 poles. The performance curves are based on the kinematic viscosity values = $1 \text{ mm}^2/\text{s}$ and density equal to $1000 \text{ kg}/\text{m}^3$. Curve tolerance according to ISO 9906.
For the MEI index, refer to the hydraulic efficiency section

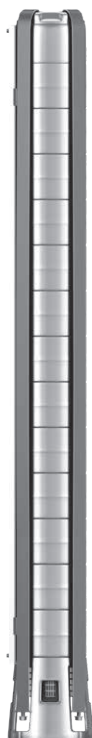

SS7

TECHNICAL DATA

Flow rate maximum: up to 110 m³/h

Head up to: 423 m

Maximum immersion depth: depending on the motor

Type of pumped liquid: clean, free from solid or abrasive substances, non-viscous, non-aggressive, non-crystallized and chemically neutral. The version in AISI 316 stainless steel is also suitable for aggressive solutions and/or salt water

Maximum sand quantity: 50 g/m³

Liquid temperature range: from 0°C to +50°C (depending on the motor)

Maximum operating pressure: depending on the motor

Flanges, thread: 5"

Pump maximum diameter: 172 mm

Impeller/s material: pressed AISI 304 stainless steel

Protection class: IP 68

Single phase power input: not available

Three phase power input: 3x230 V 50 Hz / 3x400 V 50 Hz

Power cable (m) and plug: depending on the motor (all the motor are without the power plug)

Possible type of installation: fixed in vertical position. Horizontal installation permitted by removing the non-return valve and installing a cooling jacket (check the applicability of the motor for horizontal use in the dedicated section)

Special versions on request: molded AISI 316 stainless steel construction (impellers and pump body) for aggressive water applications, delivery SS7 ports with NPT standard

7" semi axial multi-impeller submersible pump in molded AISI 304 or AISI 316 stainless steel, designed for pressurization, lifting water from underground wells, gardening and irrigation in commercial building service and irrigation also in agriculture. Ideal for installation in wells.

CONSTRUCTION FEATURES OF THE PUMP

Diffusers, impellers, supports, delivery and suction made entirely of pressed AISI 304 steel or AISI 316. Impellers balanced and keyed to the shaft with a conical coupling, specially developed to guarantee: easy assembly, avoid malfunctions due to vibrations during rotation and reduce operating noise. Shaft driven by water lubricated bearings. The diffuser geometry facilitates the expulsion of sand particles with the pumped liquid and limits the infiltration of water between the stage. Integrated non-return valve to reduce localized pressure drops. Stainless steel filter applied to the suction mouth to prevent the entry of dissolved solid bodies. Delivery port threaded according to the GAS standard. Different types of impeller are available to guarantee the best efficiency at different flow rates and models up to 22 impellers to cover a wide range of heads.

CONSTRUCTION FEATURES OF THE MOTOR

Coupling with 6" or 8" motors depending on the power required by the hydraulic system:

- 6GF: 6" submersible encapsulated motor
- TR6: 6" submersible rewindable motor
- TR8: 8" submersible rewindable motor

For operation with the variable frequency drive, refer to the specifications of the coupled motor.

For hydraulic systems in AISI 316 stainless steel, we recommend coupling with motors made of AISI 316 or DUPLEX stainless steel (check availability of the selected model).

PERFORMANCE RANGE

The performance curves are based on the kinematic viscosity values = 1 mm²/s and density equal to 1000 kg/m³. Curve tolerance according to ISO 9906.

GRAPHIC SELECTION TABLE

50 Hz - 2900 r.p.m.

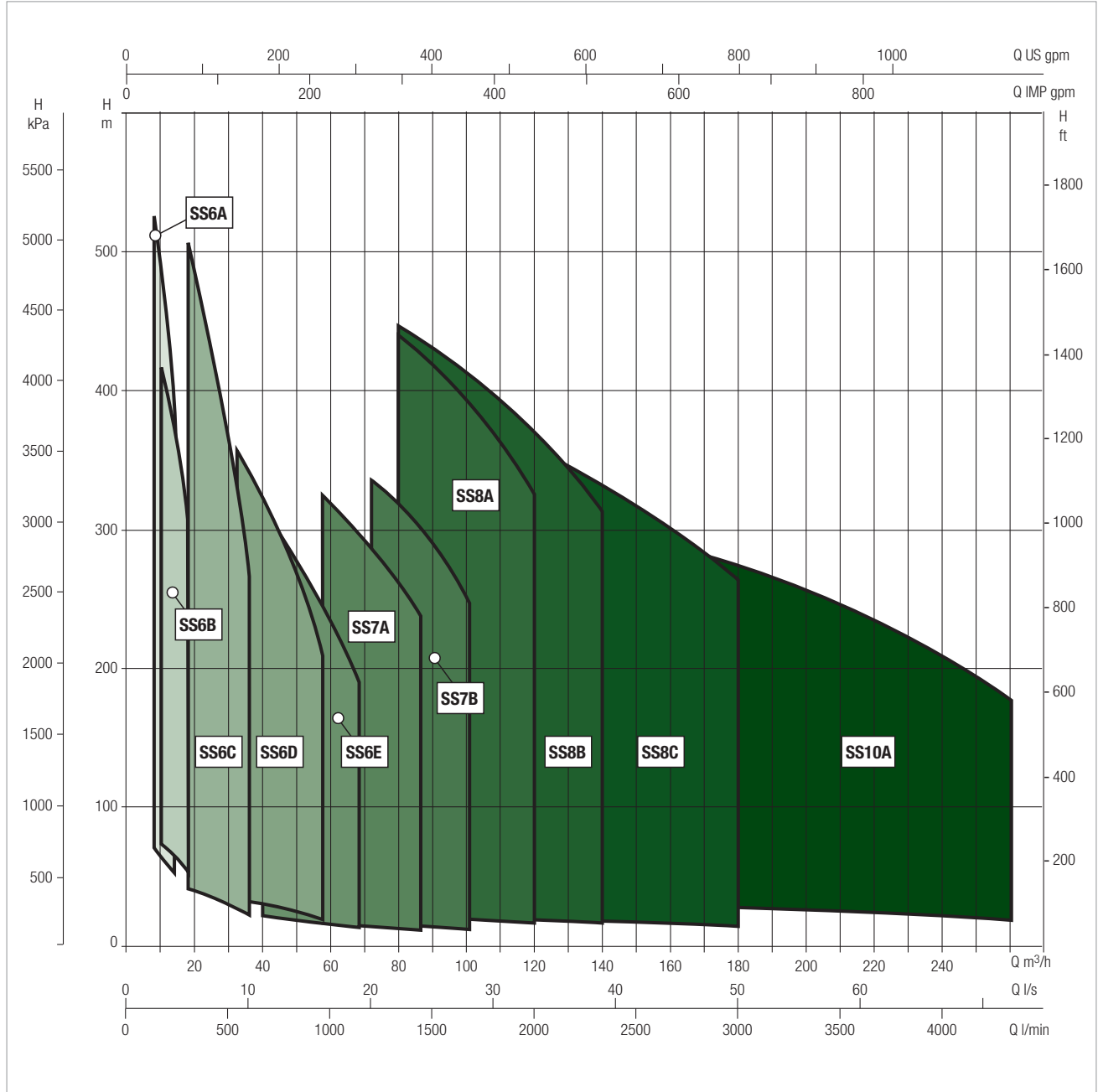

MATERIALS

N.	PARTS	MATERIALS
1	SUCTION CASE	STAINLESS STEEL (AISI 304L)
2	FILTER	STAINLESS STEEL (AISI 304L)
3	SUCTION CASE WEAR RING	BRONZE (ASTM B145-4A)
4	PUMP SHAFT	STAINLESS STEEL (AISI 420)
5	COLLET	STAINLESS STEEL
6	IMPELLER WEAR RING	STAINLESS STEEL (AISI 304)
7	IMPELLER	STAINLESS STEEL (AISI 304L)
8	DIFFUSER	STAINLESS STEEL (AISI 304L)
9	INTERMEDIATE BEARING	RUBBER
10	DIFFUSER WEAR RING	RUBBER
11	NUT FOR STOP RING	STAINLESS STEEL (AISI 304L)
12	BEARING	RUBBER
13	SHAFT STOPPER	BRONZE (ASTM B145-4A)
14	VALVE	STAINLESS STEEL (AISI 304)
15	DISCHARGE CASE	STAINLESS STEEL (AISI 304)
16	TIE ROD	STAINLESS STEEL (AISI 304L)
17	CABLE GUARD	STAINLESS STEEL (AISI 304)
18	TIE ROD NUT	STAINLESS STEEL (AISI 303)
19	NAME PLATE	STAINLESS STEEL (AISI 304)

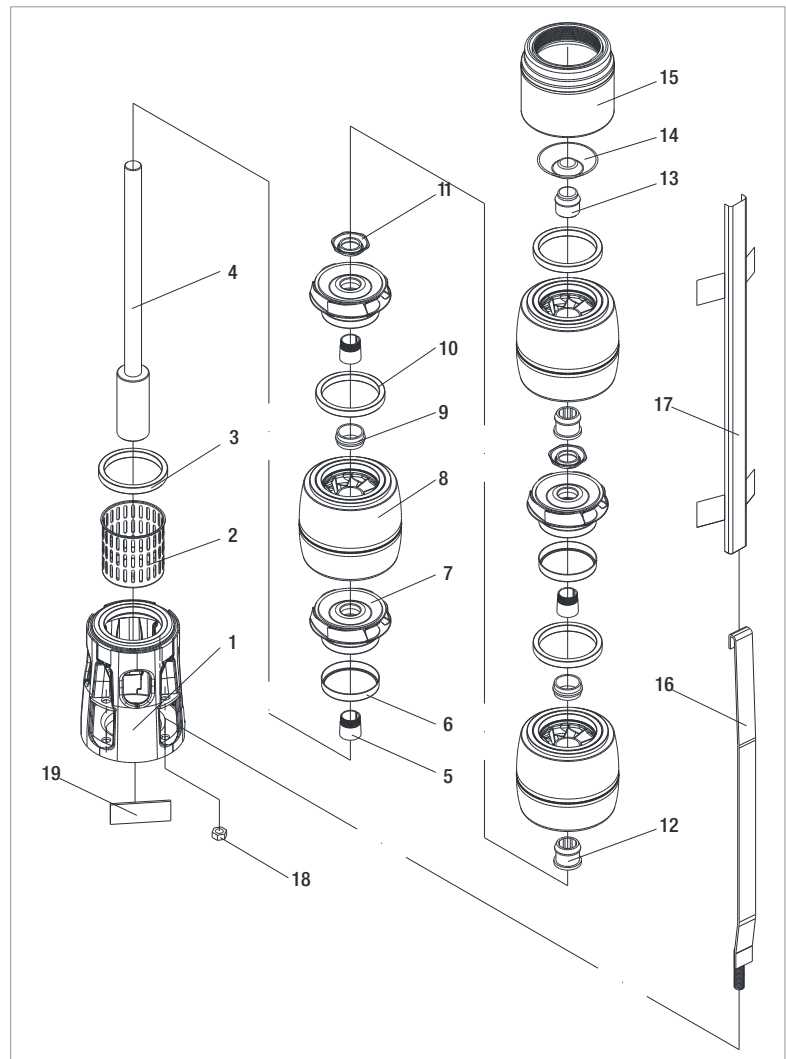

- Denomination index:
(example)

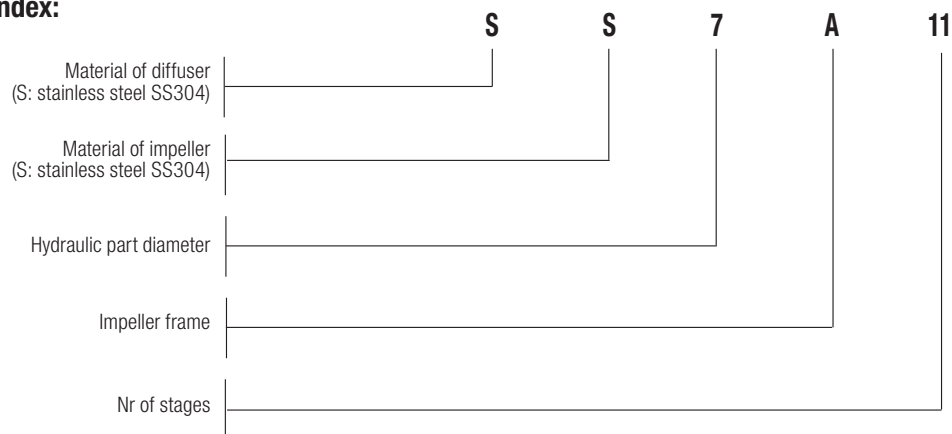

PERFORMANCE 50 HZ - 2 POLES

MODEL	ELECTRICAL DATA		HYDRAULIC DATA												STANDARD MOTOR COUPLING
	P2 NOMINAL		Q=m ³ h	0	20	30	40	50	60	70	80	90	100	115	
	kW	HP	Q=l/min	0	333,3	500	666,6	833,3	1000	1166,6	1333,3	1500	1666,6	1916,6	
SS7A 01	4	5,5	H (m)	19	19	18	17	16	15	14	12	11	8	-	6"
SS7A 02	7,5	10		38	37	36	34	32	30	28	25	21	17	-	6"
SS7A 03	11	15		58	56	54	51	49	45	42	37	32	25	-	6"
SS7A 04	15	20		77	74	72	69	65	61	56	50	42	33	-	6"
SS7A 05	18,5	25		96	93	90	86	81	76	69	62	53	41	-	6"
SS7A 06	22	30		115	111	108	103	97	91	83	74	63	50	-	6"
SS7A 07	26	35		135	130	126	120	114	106	97	87	74	58	-	6"
SS7A 08	30	40		154	149	144	137	130	121	111	99	84	66	-	6"
SS7A 09	37	50		173	167	161	154	146	136	125	111	95	75	-	6"
SS7A 10	37	50		192	186	179	172	162	152	139	124	105	83	-	6"
SS7A 11	45	60		211	204	197	189	179	167	153	136	116	91	-	8"
SS7A 12	45	60		231	223	215	206	195	182	167	149	127	99	-	8"
SS7A 13	55	75		250	241	233	223	211	197	181	161	137	108	-	8"
SS7A 14	55	75		269	260	251	240	227	212	195	173	148	116	-	8"
SS7A 15	55	75		288	278	269	257	244	227	208	186	158	124	-	8"
SS7A 16	63	85		307	297	287	275	260	243	222	198	169	133	-	8"
SS7A 17	75	100		327	316	305	292	276	258	236	210	179	141	-	8"
SS7A 18	75	100		346	334	323	309	292	273	250	223	190	149	-	8"
SS7A 19	75	100		365	353	341	326	309	288	264	235	200	158	-	8"
SS7A 20	75	100		384	371	359	343	325	303	278	248	211	166	-	8"
SS7A 21	75	100		404	390	377	360	341	318	292	260	221	174	-	8"
SS7A 22	92	125		423	408	395	378	357	334	306	272	232	182	-	8"

ELECTRICAL DATA AND DIMENSIONS

MODEL	MOTOR *	ELECTRICAL DATA				HORIZONTAL INSTALLATION	L2 mm	L mm	L1 mm	D mm	D1 mm	TOTAL WEIGHT kg
		P2 NOMINAL		In A	OPERATING BY INVERTER							
		kW	HP									
SS7A 01	6GF	4	5,5	10,6	●	●	1172	601	571	141	172	67
SS7A 02	6GF	7,5	10	18	●	●	1360	661	699	141	172	77
	TR6	7,5	10	18	○	●	1516	817	699	144	172	83
SS7A 03	6GF	11	15	25,5	●	●	1558	731	827	141	172	89
	TR6	11	15	25	○	●	1704	877	827	144	172	94
SS7A 04	6GF	15	20	33,4	●	●	1741	786	955	141	172	99
	TR6	15	20	32	○	●	1932	977	955	144	172	115
SS7A 05	6GF	18,5	25	41	●	●	1944	861	1083	141	172	111
	TR6	18,5	25	39	○	●	2120	1037	1083	144	172	122
SS7A 06	6GF	22	30	47	●	●	2132	921	1211	141	172	120,3
	TR6	22	30	49	○	●	2278	1067	1211	144	172	141
SS7A 07	6GF	26	35	57	●	●	2319	980	1339	141	172	128
	TR6	26	35	58	○	●	2476	1137	1339	144	172	155
SS7A 08	6GF	30	40	61,5	●	●	2518	1051	1467	141	172	143
	TR6	30	40	65	○	●	2659	1192	1467	144	172	164
SS7A 09	6GF	37	50	79,3	●	●	2776	1181	1595	141	172	160
	TR6	37	50	80	○	●	2887	1292	1595	144	172	171
SS7A 10	6GF	37	50	79,3	●	●	2904	1181	1723	141	172	164
	TR6	37	50	80	○	●	3015	1292	1723	144	172	175
SS7A 11	TR8	45	60	92	○	●	3121	1270	1851	192	172	243
SS7A 12	TR8	45	60	92	○	●	3249	1270	1979	192	172	247
SS7A 13	TR8	55	75	109	○	●	3457	1350	2107	192	172	266
SS7A 14	TR8	55	75	109	○	●	3585	1350	2235	192	172	270
SS7A 15	TR8	55	75	109	○	●	3713	1350	2363	192	172	274
SS7A 16	TR8	63	85	126	○	●	3981	1490	2491	192	172	304
SS7A 17	TR8	75	100	145	○	●	4209	1590	2619	192	172	326
SS7A 18	TR8	75	100	145	○	●	4337	1590	2747	192	172	330
SS7A 19	TR8	75	100	145	○	●	4465	1590	2875	192	172	334
SS7A 20	TR8	75	100	145	○	●	4593	1590	3003	192	172	338
SS7A 21	TR8	75	100	145	○	●	4721	1590	3131	192	172	342
SS7A 22	TR8	92	125	177	○	●	5089	1830	3259	192	172	392

* **6GF motor:** 6" encapsulated water-glycol-filled motor with stator immersed in thermosetting insulating resin
TR motor: 6-8" water-filled rewindable motor

- Allowed
- Only PE2 + PA version

SS7A

SUBMERSIBLE PUMPS

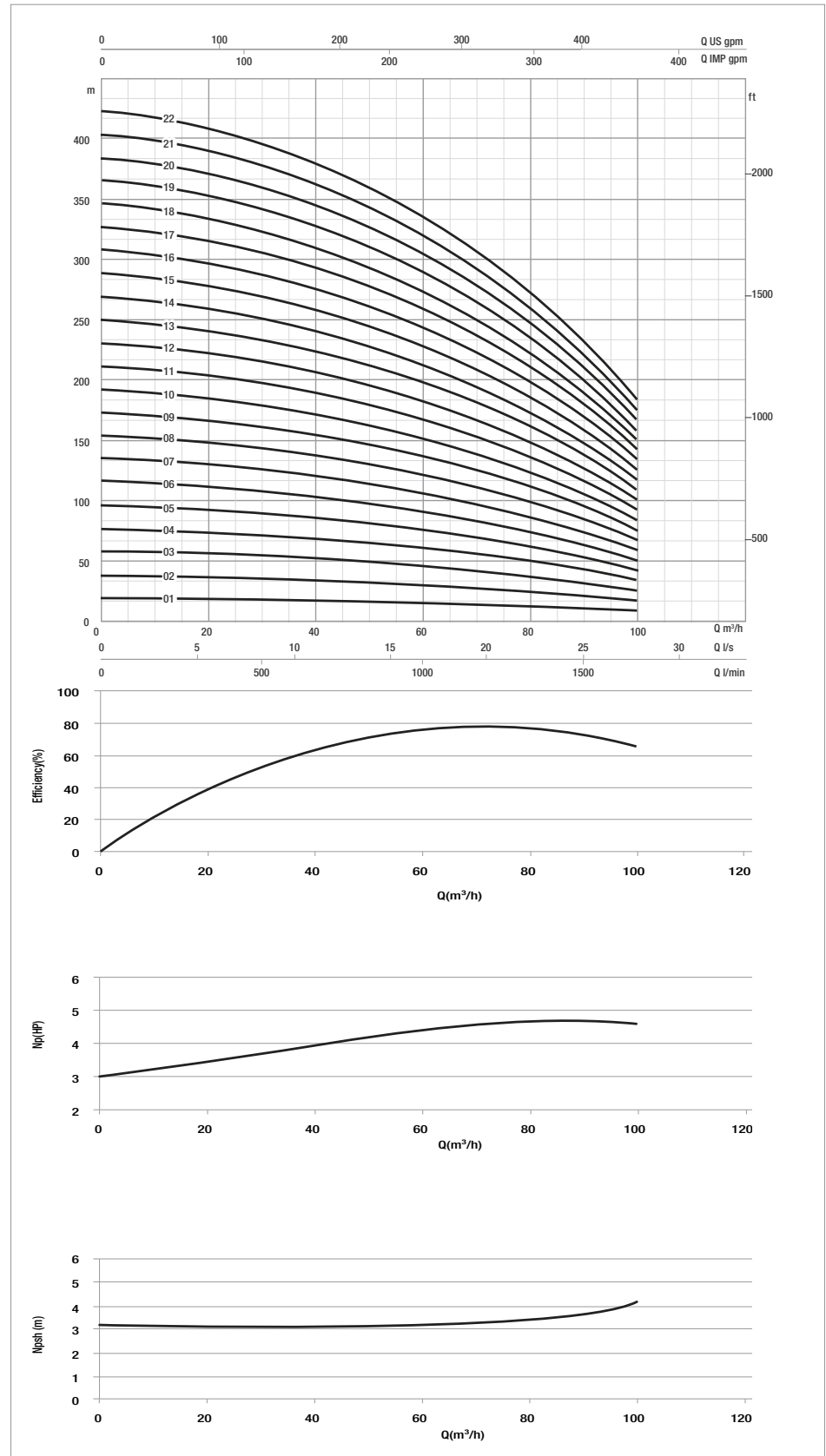
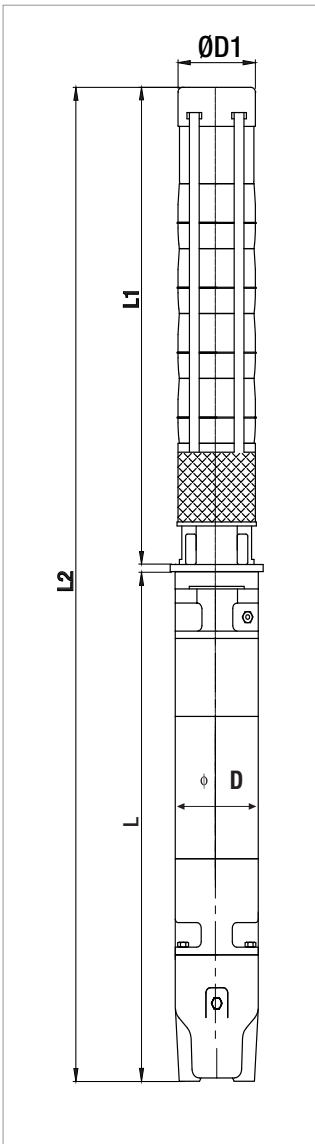

Performance 50 Hz - 2 poles. The performance curves are based on the kinematic viscosity values = $1 \text{ mm}^2/\text{s}$ and density equal to $1000 \text{ kg}/\text{m}^3$. Curve tolerance according to ISO 9906.

PERFORMANCE 50 HZ - 2 POLES

MODEL	ELECTRICAL DATA		Q=m³h Q=l/min	HYDRAULIC DATA											STANDARD MOTOR COUPLING
	P2 NOMINAL			0	20	30	40	50	60	70	80	90	100	115	
	kW	HP		0	333,3	500	666,6	833,3	1000	1166,6	1333,3	1500	1666,6	1916,6	
SS7B 01	5,5	7,5	H (m)	21	21	-	20	20	19	18	17	16	14	11	6"
SS7B 02	11	15		43	43	-	41	39	38	36	34	32	28	21	6"
SS7B 03	15	20		64	64	-	61	59	56	54	51	47	43	32	6"
SS7B 04	22	30		85	86	-	81	78	75	72	68	63	57	43	6"
SS7B 05	30	40		106	107	-	101	98	94	90	85	79	71	54	6"
SS7B 06	37	50		128	128	-	122	117	113	108	102	95	85	64	6"
SS7B 07	37	50		149	150	-	142	137	132	126	119	111	100	75	6"
SS7B 08	45	60		170	171	-	162	156	150	144	136	126	114	86	8"
SS7B 09	45	60		192	193	-	183	176	169	162	153	142	128	96	8"
SS7B 10	55	75		213	214	-	203	196	188	180	170	158	142	107	8"
SS7B 11	63	85		234	235	-	223	215	207	197	187	174	157	118	8"
SS7B 12	75	100		256	257	-	243	235	225	215	204	190	171	128	8"
SS7B 13	75	100		277	278	-	264	254	244	233	221	206	185	139	8"
SS7B 14	75	100		298	300	-	284	274	263	251	238	221	199	150	8"
SS7B 15	92	125		319	321	-	304	293	282	269	255	237	214	161	8"
SS7B 16	92	125		341	342	-	325	313	301	287	272	253	228	171	8"
SS7B 17	92	125		362	364	-	345	332	319	305	289	269	242	182	8"
SS7B 18	110	150		383	385	-	365	352	338	323	306	285	256	193	8"
SS7B 19	110	150		405	407	-	385	372	357	341	323	300	271	203	8"
SS7B 20	110	150		426	428	-	406	391	376	359	340	316	285	214	8"

ELECTRICAL DATA AND DIMENSIONS

MODEL	MOTOR *	ELECTRICAL DATA				HORIZONTAL INSTALLATION	L2 mm	L mm	L1 mm	D mm	D1 mm	TOTAL WEIGHT kg
		P2 NOMINAL		In A	OPERATING BY INVERTER							
		kW	HP									
SS7B 01	6GF	5,5	7,5	14	●	●	1202	631	571	141	172	70
	TR6	5,5	7,5	13	○	●	1358	787	571	144	172	76
SS7B 02	6GF	11	15	25,5	●	●	1430	731	699	141	172	85
	TR6	11	15	25	○	●	1576	877	699	144	172	90
SS7B 03	6GF	15	20	33,4	●	●	1613	786	827	141	172	95
	TR6	15	20	32	○	●	1804	977	827	144	172	111
SS7B 04	6GF	22	30	47	●	●	1876	921	955	141	172	112,3
	TR6	22	30	49	○	●	2022	1067	955	144	172	133
SS7B 05	6GF	30	40	61,5	●	●	2134	1051	1083	141	172	131
	TR6	30	40	65	○	●	2275	1192	1083	144	172	152
SS7B 06	6GF	37	50	79,3	●	●	2392	1181	1211	141	172	148
	TR6	37	50	80	○	●	2503	1292	1211	144	172	159
SS7B 07	6GF	37	50	79,3	●	●	2520	1181	1339	141	172	152
	TR6	37	50	80	○	●	2631	1292	1339	144	172	163
SS7B 08	TR8	45	60	92	○	●	2737	1270	1467	192	172	231
SS7B 09	TR8	45	60	92	○	●	2865	1270	1595	192	172	235
SS7B 10	TR8	55	75	109	○	●	3073	1350	1723	192	172	254
SS7B 11	TR8	63	85	126	○	●	3341	1490	1851	192	172	284
SS7B 12	TR8	75	100	145	○	●	3569	1590	1979	192	172	307
SS7B 13	TR8	75	100	145	○	●	3697	1590	2107	192	172	311
SS7B 14	TR8	75	100	145	○	●	3825	1590	2235	192	172	315
SS7B 15	TR8	92	125	177	○	●	4193	1830	2363	192	172	365
SS7B 16	TR8	92	125	177	○	●	4321	1830	2491	192	172	369
SS7B 17	TR8	92	125	177	○	●	4449	1830	2619	192	172	373
SS7B 18	TR8	110	150	213	○	●	4807	2060	2747	192	172	427
SS7B 19	TR8	110	150	213	○	●	4935	2060	2875	192	172	431
SS7B 20	TR8	110	150	213	○	●	5063	2060	3003	192	172	435

* **6GF motor:** 6" encapsulated water-glycol-filled motor with stator immersed in thermosetting insulating resin
TR motor: 6-8" water-filled rewindable motor

●	Allowed
○	Only PE2 + PA version

SS7B

SUBMERSIBLE PUMPS

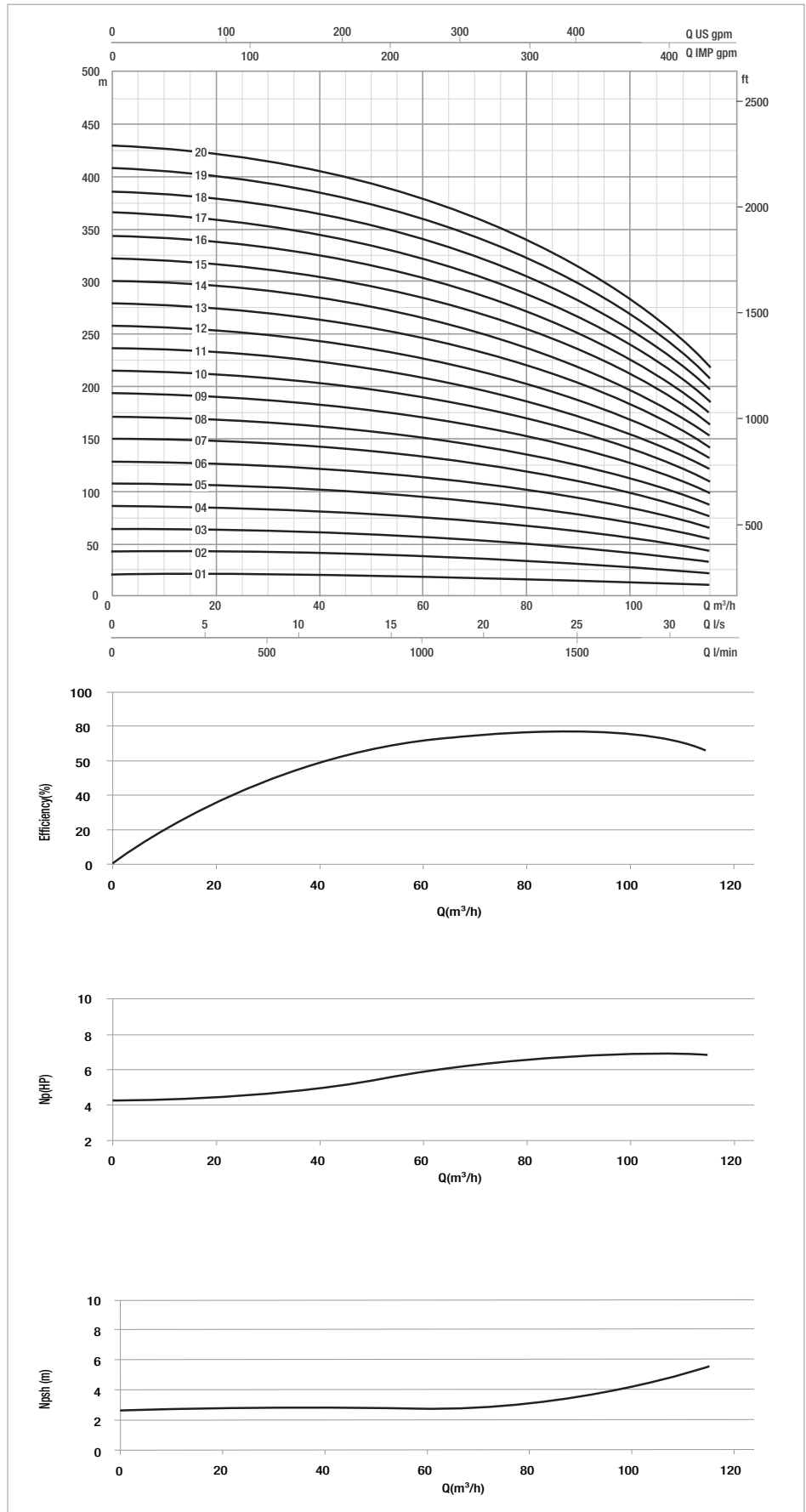
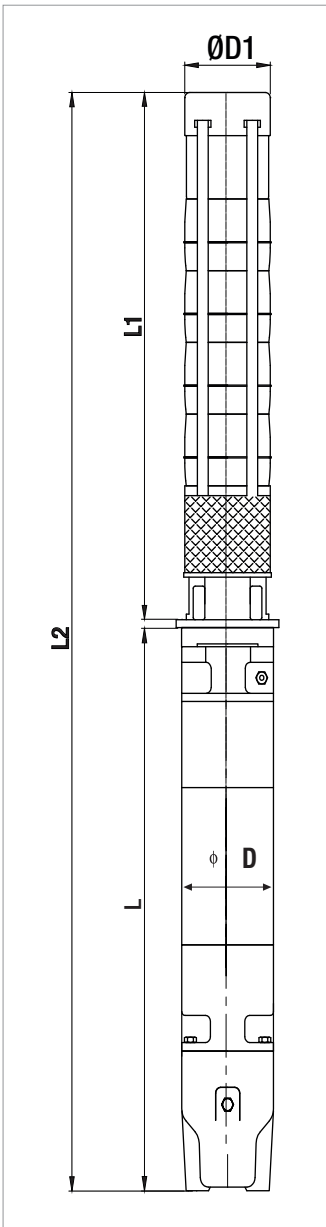

Performance 50 Hz - 2 poles. The performance curves are based on the kinematic viscosity values = $1 \text{ mm}^2/\text{s}$ and density equal to $1000 \text{ kg}/\text{m}^3$. Curve tolerance according to ISO 9906.



TECHNICAL DATA

Flow rate maximum: up to 210 m³/h

Head up to: 555 m

Maximum immersion depth: depending on the motor

Type of pumped liquid: clean, free from solid or abrasive substances, non-viscous, non-aggressive, non-crystallized and chemically neutral. The version in AISI 316 stainless steel is also suitable for aggressive solutions and/or salt water

Maximum sand quantity: 50 g/m³

Liquid temperature range: from 0°C to +50°C (depending on the motor)

Maximum operating pressure: depending on the motor

Flanges, thread: 6"

Pump maximum diameter: 226 mm

Impeller/s material/s: pressed AISI 304 stainless steel

Protection class: IP 68

Single phase power input: not available

Three phase power input: 3x230 V 50 Hz / 3x400 V 50 Hz

Power cable (m) and plug: depending on the motor (all the motor are without the power plug)

Possible type of installation: fixed in vertical position. Horizontal installation permitted by removing the non-return valve and installing a cooling jacket (check the applicability of the motor for horizontal use in the dedicated section)

Special versions on request: molded AISI 316 stainless steel construction (impellers and pump body) for aggressive water applications, delivery ports with NPT standard

8" semi axial multi-impeller submersible pump in molded AISI 304 or AISI 316 stainless steel, designed for pressurization, lifting water from wells, gardening and irrigation in commercial building service and irrigation also in agriculture. Ideal for installation in wells.

CONSTRUCTION FEATURES OF THE PUMP

Diffusers, impellers, supports, delivery and suction made entirely of pressed AISI 304 steel or AISI 316. Impellers balanced and keyed to the shaft with a conical coupling, specially developed to guarantee: easy assembly, avoid malfunctions due to vibrations during rotation and reduce operating noise. Shaft driven by water lubricated bearings. The diffuser geometry facilitates the expulsion of sand particles with the pumped liquid and limits the infiltration of water between the stage. Integrated non-return valve to reduce localized pressure drops. Stainless steel filter applied to the suction mouth to prevent the entry of dissolved solid bodies. Delivery port threaded according to the GAS standard. Different types of impeller are available to guarantee the best efficiency at different flow rates and models up to 20 impellers to cover a wide range of heads.

CONSTRUCTION FEATURES OF THE MOTOR

Coupling with 6" or 10" motors depending on the power required by the hydraulic system:

- 6GF: 6" submersible encapsulated motor
- TR6: 6" submersible rewindable motor
- TR8: 8" submersible rewindable motor
- TR10: 10" submersible rewindable motor

For operation with the variable frequency drive, refer to the specifications of the coupled motor.

For hydraulic systems in AISI 316 stainless steel, we recommend coupling with motors made of AISI 316 or DUPLEX stainless steel (check availability of the selected model).

PERFORMANCE RANGE

The performance curves are based on the kinematic viscosity values = 1 mm²/s and density equal to 1000 kg/m³. Curve tolerance according to ISO 9906.

GRAPHIC SELECTION TABLE

50 Hz - 2900 r.p.m.

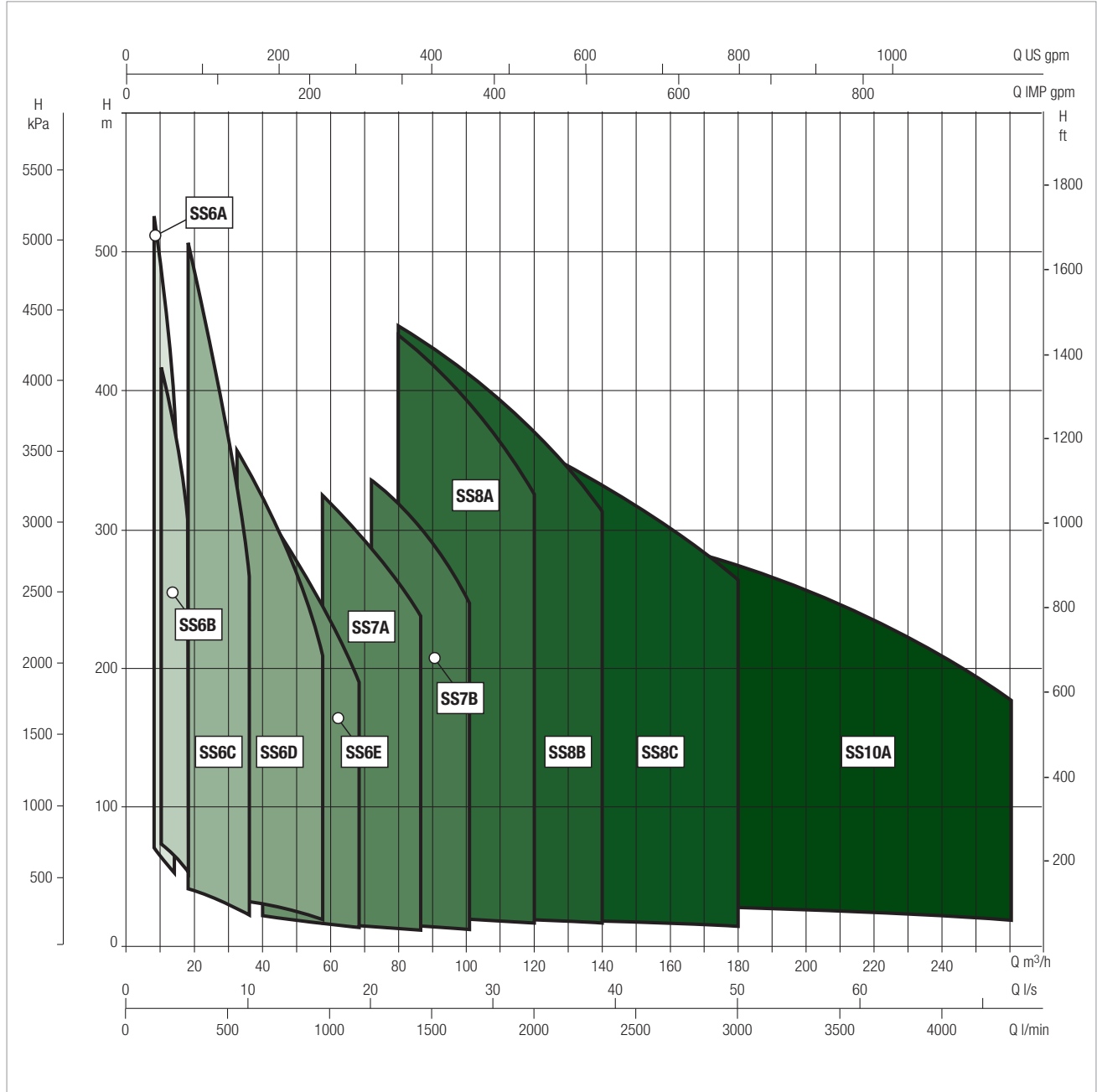

MATERIALS

N.	PARTS	MATERIALS
1	SUCTION CASE	STAINLESS STEEL (AISI 304L)
2	FILTER	STAINLESS STEEL (AISI 304L)
3	SUCTION CASE WEAR RING	BRONZE (ASTM B145-4A)
4	PUMP SHAFT	STAINLESS STEEL (AISI 420)
5	COLLET	STAINLESS STEEL
6	IMPELLER WEAR RING	STAINLESS STEEL (AISI 304)
7	IMPELLER	STAINLESS STEEL (AISI 304L)
8	DIFFUSER	STAINLESS STEEL (AISI 304L)
9	INTERMEDIATE BEARING	RUBBER
10	DIFFUSER WEAR RING	RUBBER
11	NUT FOR STOP RING	STAINLESS STEEL (AISI 304L)
12	BEARING	RUBBER
13	SHAFT STOPPER	BRONZE (ASTM B145-4A)
14	VALVE	STAINLESS STEEL (AISI 304)
15	DISCHARGE CASE	STAINLESS STEEL (AISI 304)
16	TIE ROD	STAINLESS STEEL (AISI 304L)
17	CABLE GUARD	STAINLESS STEEL (AISI 304)
18	TIE ROD NUT	STAINLESS STEEL (AISI 303)
19	NAME PLATE	STAINLESS STEEL (AISI 304)

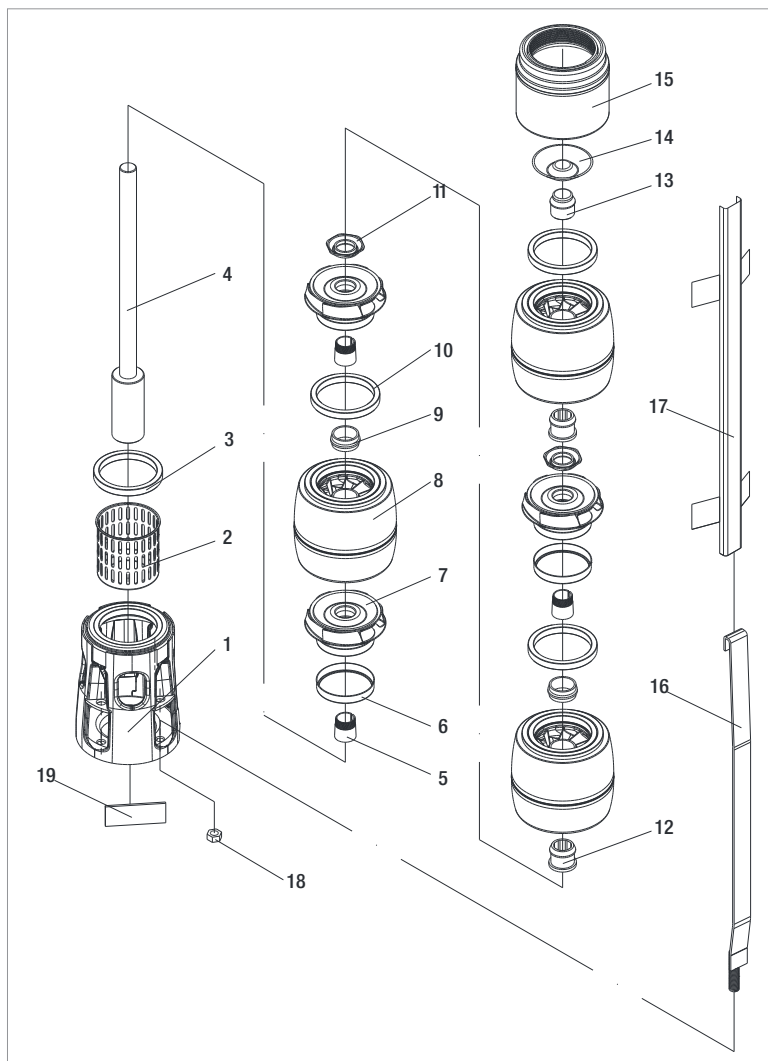

- Denomination index:
(example)

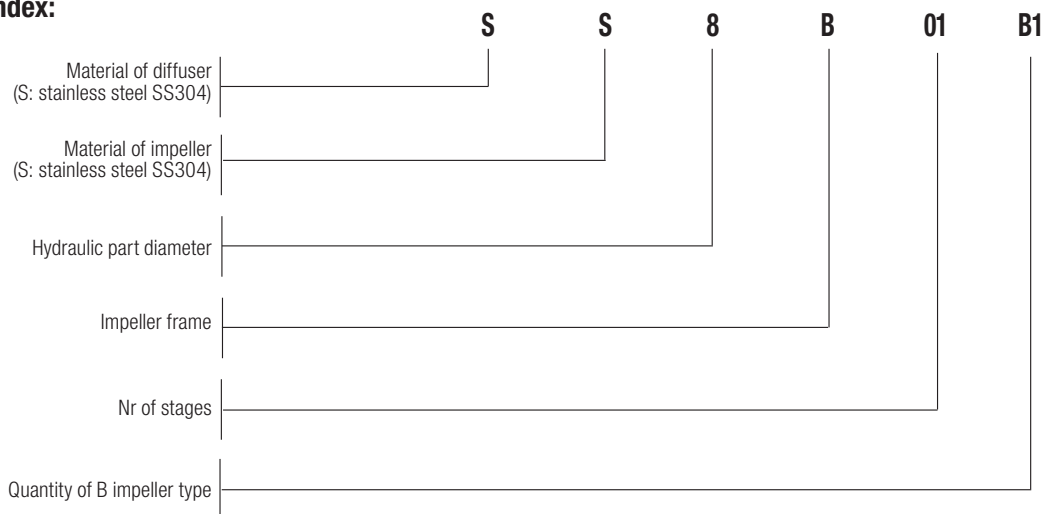

PERFORMANCE 50 Hz - 2 POLES

MODEL	ELECTRICAL DATA		HYDRAULIC DATA											STANDARD MOTOR COUPLING
	P2 NOMINAL		Q=m³h	0	30	70	80	90	100	110	120	130	140	
	kW	HP	Q=l/min	0	500	1166,6	1333,3	1500	1666,6	1833,3	2000	2166,6	2333,3	
SS8A 01	7,5	10	H (m)	28	26	23	22	21	20	18	16	15	12	6"
SS8A 02	15	20		56	52	46	44	42	39	36	33	29	24	6"
SS8A 03	22	30		83	78	69	66	63	59	54	49	44	37	6"
SS8A 04	30	40		111	104	91	88	83	78	73	66	58	49	6"
SS8A 05	37	50		139	129	114	110	104	98	91	82	73	61	6"
SS8A 06	45	60		167	155	137	131	125	118	109	99	87	73	8"
SS8A 07	55	75		194	181	160	153	146	137	127	115	102	86	8"
SS8A 08	63	85		222	207	183	175	167	157	145	132	116	98	8"
SS8A 09	75	100		250	233	206	197	188	176	163	148	131	110	8"
SS8A 10	75	100		278	259	229	219	208	196	182	165	145	122	8"
SS8A 11	92	125		305	285	252	241	229	216	200	181	160	135	8"
SS8A 12	92	125		333	311	274	263	250	235	218	198	174	147	8"
SS8A 13	92	125		361	337	297	285	271	255	236	214	189	159	8"
SS8A 14	110	150		389	362	320	307	292	274	254	231	203	171	8"
SS8A 15	110	150		416	388	343	329	313	294	272	247	218	184	8"
SS8A 16	132	180		444	414	366	351	333	313	290	264	232	196	10"
SS8A 17	132	180		472	440	389	373	354	333	309	280	247	208	10"
SS8A 18	132	180		500	466	412	394	375	353	327	297	262	220	10"
SS8A 19	147	200		527	492	435	416	396	372	345	313	276	233	10"
SS8A 20	147	200		555	518	457	438	417	392	363	330	291	245	10"

ELECTRICAL DATA AND DIMENSIONS

MODEL	MOTOR *	ELECTRICAL DATA				HORIZONTAL INSTALLATION	L2 mm	L mm	L1 mm	D mm	D1 mm	TOTAL WEIGHT kg
		P2 NOMINAL		In A	OPERATING BY INVERTER							
		kW	HP									
SS8A 01	6GF	7,5	10	18	●	●	1347	661	686	141	213	79
	TR6	7,5	10	18	○	●	1503	817	686	144	213	82
SS8A 02	6GF	15	20	33,4	●	●	1628	786	842	141	213	99
	TR6	15	20	32	○	●	1819	977	842	144	213	115
SS8A 03	6GF	22	30	47	●	●	1918	921	997	141	213	119,3
	TR6	22	30	49	○	●	2064	1067	997	144	213	140
SS8A 04	6GF	30	40	61,5	●	●	2204	1051	1153	141	213	140
	TR6	30	40	65	○	●	2345	1192	1153	144	213	161
SS8A 05	6GF	37	50	79,3	●	●	2490	1181	1309	141	213	159
	TR6	37	50	80	○	●	2601	1292	1309	144	213	170
SS8A 06	TR8	45	60	92	○	●	2735	1270	1465	192	213	241
SS8A 07	TR8	55	75	109	○	●	2970	1350	1620	192	213	262
SS8A 08	TR8	63	85	126	○	●	3266	1490	1776	192	213	294
SS8A 09	TR8	75	100	145	○	●	3522	1590	1932	192	213	320
SS8A 10	TR8	75	100	145	○	●	3677	1590	2087	192	213	326
SS8A 11	TR8	92	125	177	○	●	4073	1830	2243	192	213	378
SS8A 12	TR8	92	125	177	○	●	4229	1830	2399	192	213	384
SS8A 13	TR8	92	125	177	○	●	4384	1830	2554	192	213	391
SS8A 14	TR8	110	150	213	○	●	4770	2060	2710	192	213	447
SS8A 15	TR8	110	150	213	○	●	4926	2060	2866	192	213	453
SS8A 16	TR10	132	180	257	○	●	4892	1870	3022	237	213	562
SS8A 17	TR10	132	180	257	○	●	5047	1870	3177	237	213	568
SS8A 18	TR10	132	180	257	○	●	5203	1870	3333	237	213	574
SS8A 19	TR10	147	200	300	○	●	5559	2070	3489	237	213	645
SS8A 20	TR10	147	200	300	○	●	5714	2070	3644	237	213	652

* 6GF motor: 6" encapsulated water-glycol-filled motor with stator immersed in thermosetting insulating resin
 TR motor: 6-8-10" riavvolgibile in bagno d'acqua.

●	Allowed
○	Only PE2 + PA version

SS8A

SUBMERSIBLE PUMPS

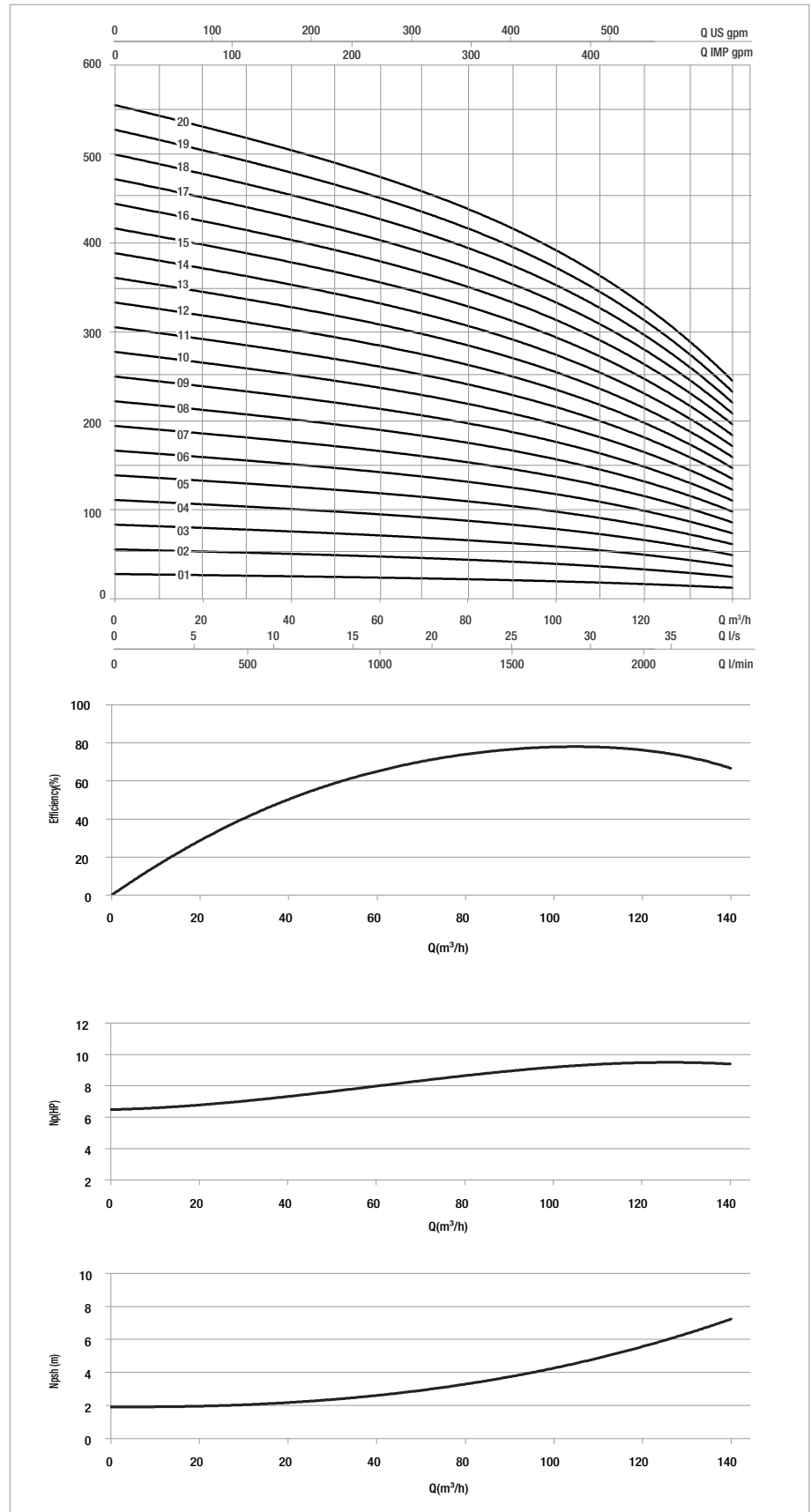
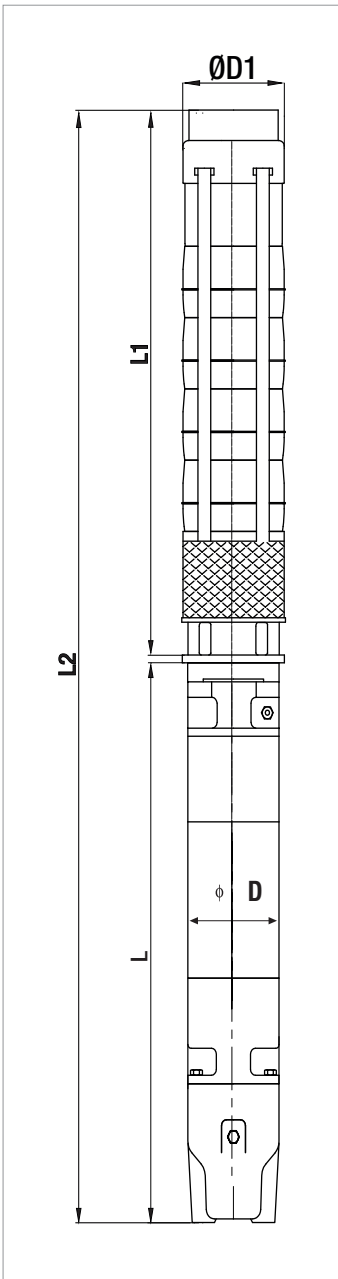

The performance curves are based on the kinematic viscosity values = 1 mm²/s and density equal to 1000 kg/m³. Curve tolerance according to ISO 9906.

PERFORMANCE 50 HZ - 2 POLES

MODEL	ELECTRICAL DATA		HYDRAULIC DATA										STANDARD MOTOR COUPLING	
	P2 NOMINAL		Q=m³h	0	40	70	90	120	130	140	150	160		170
	kW	HP	Q=l/min	0	666,6	1166,6	1500	2000	2166,6	2333,3	2500	2666,6		2833,3
SS8B 01.B1	9,3	12,5	H (m)	27	25	23	22	19	18	17	16	14	12	6"
SS8B 01	11	15		33	31	28	27	24	23	21	19	17	14	6"
SS8B 02.B2	18,5	25		54	50	46	44	39	37	34	32	28	24	6"
SS8B 02	22	30		65	61	57	53	48	45	42	38	34	29	6"
SS8B 03.B3	30	40		80	75	70	66	58	55	52	47	42	35	6"
SS8B 03	37	50		98	92	85	80	71	68	63	58	51	43	6"
SS8B 04	45	60		131	122	113	107	95	90	84	77	68	58	8"
SS8B 05.B3	55	75		146	136	126	119	106	100	94	86	76	64	8"
SS8B 05	55	75		163	153	142	134	119	113	105	96	85	72	8"
SS8B 06	75	100		196	183	170	160	143	135	126	115	102	87	8"
SS8B 07	75	100		228	214	198	187	166	158	147	135	119	101	8"
SS8B 08	92	125		261	245	227	214	190	180	168	154	136	115	8"
SS8B 09	110	150		294	275	255	240	214	203	189	173	153	130	8"
SS8B 10	110	150	326	306	283	267	238	225	210	192	171	144	8"	
SS8B 11	132	180	359	336	312	294	261	248	231	211	188	159	10"	
SS8B 12	132	180	392	367	340	320	285	270	252	231	205	173	10"	
SS8B 13	147	200	424	397	368	347	309	293	273	250	222	187	10"	

ELECTRICAL DATA AND DIMENSIONS

MODEL	MOTOR *	ELECTRICAL DATA				HORIZONTAL INSTALLATION	L2 mm	L mm	L1 mm	D mm	D1 mm	TOTAL WEIGHT kg
		P2 NOMINAL		In A	OPERATING BY INVERTER							
		kW	HP									
SS8B 01.B1	6GF	9,3	12,5	22	●	●	1372	686	686	141	213	82
	TR6	9,3	12,5	21	○	●	1533	847	686	144	213	87
SS8B 01	6GF	11	15	25,5	●	●	1417	731	686	141	213	87
	TR6	11	15	25	○	●	1563	877	686	144	213	92
SS8B 02.B2	6GF	18,5	25	41	●	●	1703	861	842	141	213	108
	TR6	18,5	25	39	○	●	1879	1037	842	144	213	119
SS8B 02	6GF	22	30	47	●	●	1763	921	842	141	213	113,3
	TR6	22	30	49	○	●	1909	1067	842	144	213	134
SS8B 03.B3	6GF	30	40	61,5	●	●	2048	1051	997	141	213	134
	TR6	30	40	65	○	●	2189	1192	997	144	213	155
SS8B 03	6GF	37	50	79,3	●	●	2178	1181	997	141	213	147
	TR6	37	50	80	○	●	2289	1292	997	144	213	158
SS8B 04	TR8	45	60	92	○	●	2423	1270	1153	192	213	229
SS8B 05.B3	TR8	55	75	109	○	●	2659	1350	1309	192	213	250
SS8B 05	TR8	55	75	109	○	●	2659	1350	1309	192	213	250
SS8B 06	TR8	75	100	145	○	●	3055	1590	1465	192	213	302
SS8B 07	TR8	75	100	145	○	●	3210	1590	1620	192	213	308
SS8B 08	TR8	92	125	177	○	●	3606	1830	1776	192	213	361
SS8B 09	TR8	110	150	213	○	●	3992	2060	1932	192	213	417
SS8B 10	TR8	110	150	213	○	●	4147	2060	2087	192	213	424
SS8B 11	TR10	132	180	257	○	●	4113	1870	2243	237	213	532
SS8B 12	TR10	132	180	257	○	●	4269	1870	2399	237	213	539
SS8B 13	TR10	147	200	300	○	●	4624	2070	2554	237	213	610

* **6GF motor:** 6" encapsulated water-glycol-filled motor with stator immersed in thermosetting insulating resin
TR motor: 6-8-10" water-filled rewindable motor.

●	Allowed
○	Only PE2 + PA version

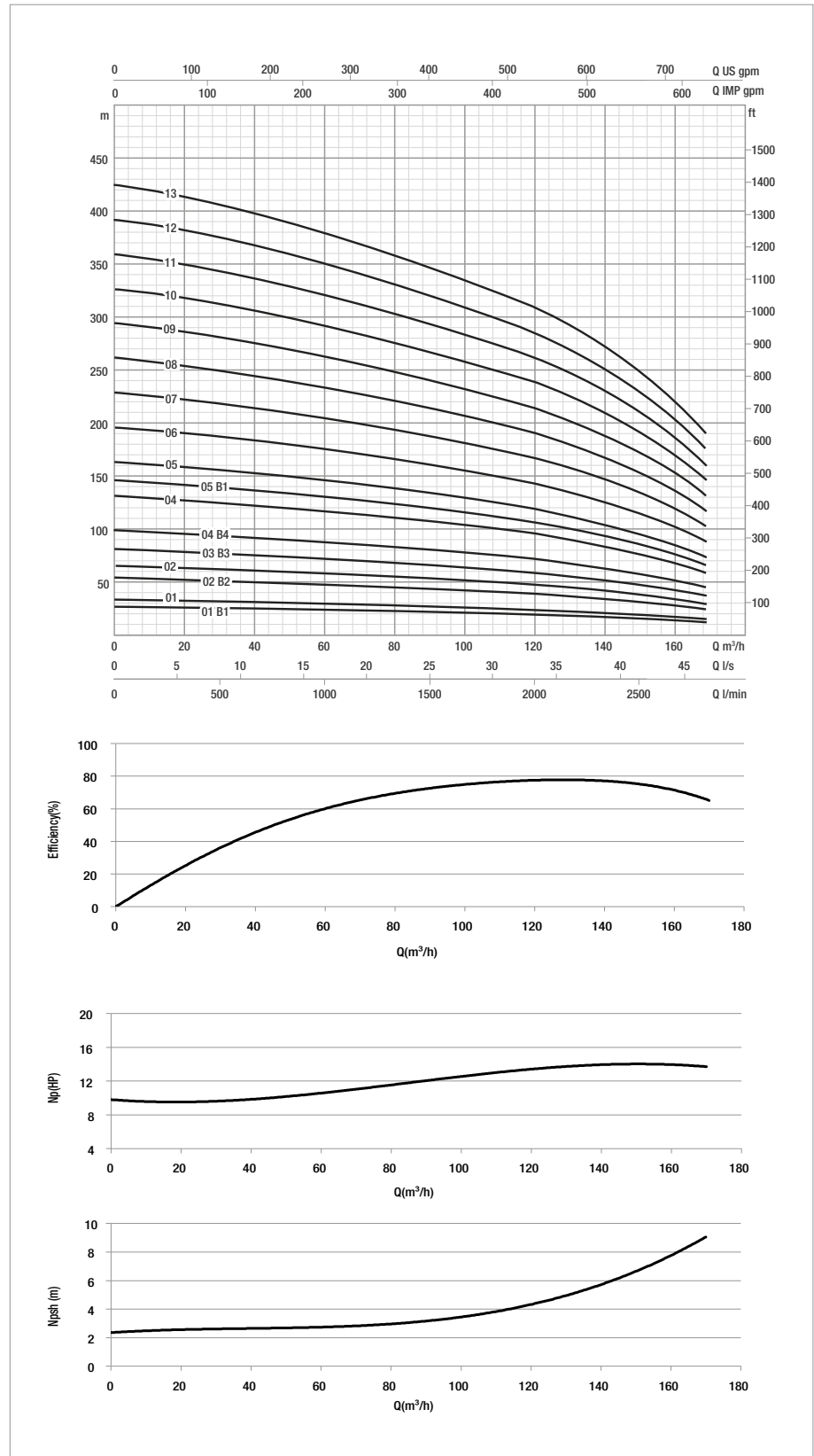
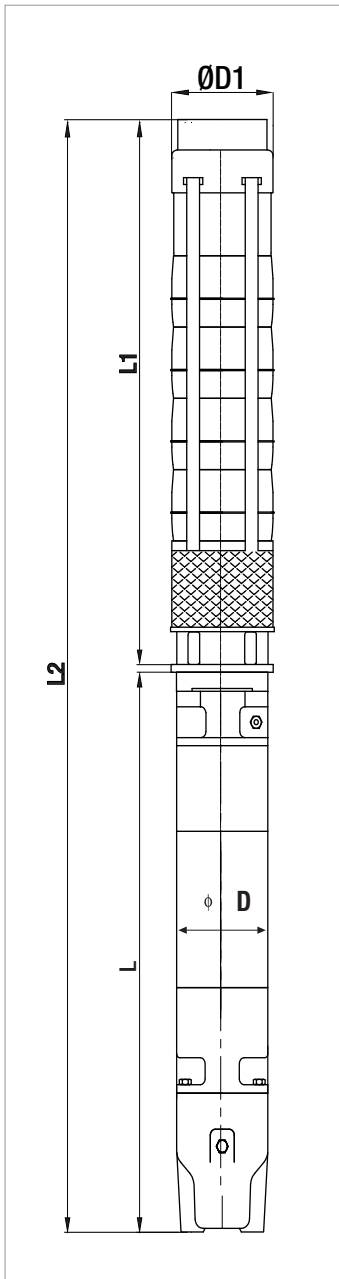

The performance curves are based on the kinematic viscosity values = 1 mm²/s and density equal to 1000 kg/m³. Curve tolerance according to ISO 9906.

PERFORMANCE 50 Hz - 2 POLES

MODEL	ELECTRICAL DATA		Q=m ³ h Q=l/min	HYDRAULIC DATA										STANDARD MOTOR COUPLING
	P2 NOMINAL			0	50	70	90	110	130	150	170	190	210	
	kW	HP		0	833,3	1166,6	1500	1833,3	2166,6	2500	2833,3	3166,6	3500	
SS8C 01.B1	9,3	12,5	H (m)	24	22	21	20	18	17	16	14	12	9	6"
SS8C 01	11	15		30	28	26	24	23	22	20	18	15	11	6"
SS8C 02.B2	18,5	25		48	44	42	39	37	34	32	28	23	17	6"
SS8C 02	22	30		60	55	52	49	26	43	40	35	29	22	6"
SS8C 03.B3	30	40		78	72	68	64	60	56	52	46	38	28	6"
SS8C 03	37	50		90	83	78	73	69	65	60	53	44	32	6"
SS8C 04	45	60		120	111	104	98	92	86	80	71	58	43	8"
SS8C 05	55	75		150	139	130	122	115	108	99	88	73	54	8"
SS8C 06.B3	63	85		162	150	141	132	124	116	107	95	79	58	8"
SS8C 06	75	100		180	166	156	147	138	129	119	106	88	65	8"
SS8C 07.B3	75	100		192	177	167	156	147	138	127	113	94	69	8"
SS8C 07	92	125		210	194	182	171	161	151	139	124	102	76	8"
SS8C 08	92	125		240	222	208	195	184	172	159	141	117	87	8"
SS8C 09	110	150		270	249	234	220	207	194	179	159	132	97	8"
SS8C 10	110	150		300	277	260	244	230	215	199	176	146	108	8"
SS8C 11	132	180		330	305	286	269	253	237	219	194	161	119	10"
SS8C 12	147	200	360	333	312	293	276	259	239	212	175	130	10"	
SS8C 13	147	200	390	360	338	318	299	280	258	229	190	141	10"	
SS8C 14	170	230	420	388	364	342	322	302	278	247	205	152	10"	
SS8C 15	190	260	450	416	390	366	345	323	298	265	219	162	10"	
SS8C 16	190	260	480	443	416	391	368	345	318	282	234	173	10"	

ELECTRICAL DATA AND DIMENSIONS

MODEL	MOTOR *	ELECTRICAL DATA				HORIZONTAL INSTALLATION	L2 mm	L mm	L1 mm	D mm	D1 mm	TOTAL WEIGHT kg
		P2 NOMINAL		In A	OPERATING BY INVERTER							
		kW	HP									
SS8C 01.B1	6GF	9,3	12,5	22	●	●	1372	686	686	141	226	84
	TR6	9,3	12,5	21	○	●	1533	847	686	144	226	89
SS8C 01	6GF	11	15	25,5	●	●	1417	731	686	141	226	89
	TR6	11	15	25	○	●	1563	877	686	144	226	94
SS8C 02.B2	6GF	18,5	25	41	●	●	1703	861	842	141	226	109
	TR6	18,5	25	39	○	●	1879	1037	842	144	226	120
SS8C 02	6GF	22	30	47	●	●	1763	921	842	141	226	114,3
	TR6	22	30	49	○	●	1909	1067	842	144	226	135
SS8C 03.B3	6GF	30	40	61,5	●	●	2048	1051	997	141	226	136
	TR6	30	40	65	○	●	2189	1192	997	144	226	157
SS8C 03	6GF	37	50	79,3	●	●	2178	1181	997	141	226	149
	TR6	37	50	80	○	●	2289	1292	997	144	226	160
SS8C 04	TR8	45	60	92	○	●	2423	1270	1153	192	226	230
SS8C 05	TR8	55	75	109	○	●	2659	1350	1309	192	226	252
SS8C 06.B3	TR8	63	85	126	○	●	2955	1490	1465	192	226	284
SS8C 06	TR8	75	100	145	○	●	3055	1590	1465	192	226	303
SS8C 07.B3	TR8	75	100	145	○	●	3210	1590	1620	192	226	310
SS8C 07	TR8	92	125	177	○	●	3450	1830	1620	192	226	356
SS8C 08	TR8	92	125	177	○	●	3606	1830	1776	192	226	362
SS8C 09	TR8	110	150	213	○	●	3992	2060	1932	192	226	419
SS8C 10	TR8	110	150	213	○	●	4147	2060	2087	192	226	425
SS8C 11	TR10	132	180	257	○	●	4113	1870	2243	237	226	534
SS8C 12	TR10	147	200	300	○	●	4469	2070	2399	237	226	605
SS8C 13	TR10	147	200	300	○	●	4624	2070	2554	237	226	612
SS8C 14	TR10	170	230	348	○	●	4930	2220	2710	237	226	658
SS8C 15	TR10	190	260	405	○	●	5266	2400	2866	237	226	704
SS8C 16	TR10	190	260	405	○	●	5422	2400	3022	237	226	711

* **6GF motor:** 6" encapsulated water-glycol-filled motor with stator immersed in thermosetting insulating resin
TR motor: 6-8-10" water-filled rewindable motor.

- Allowed
- Only PE2 + PA version

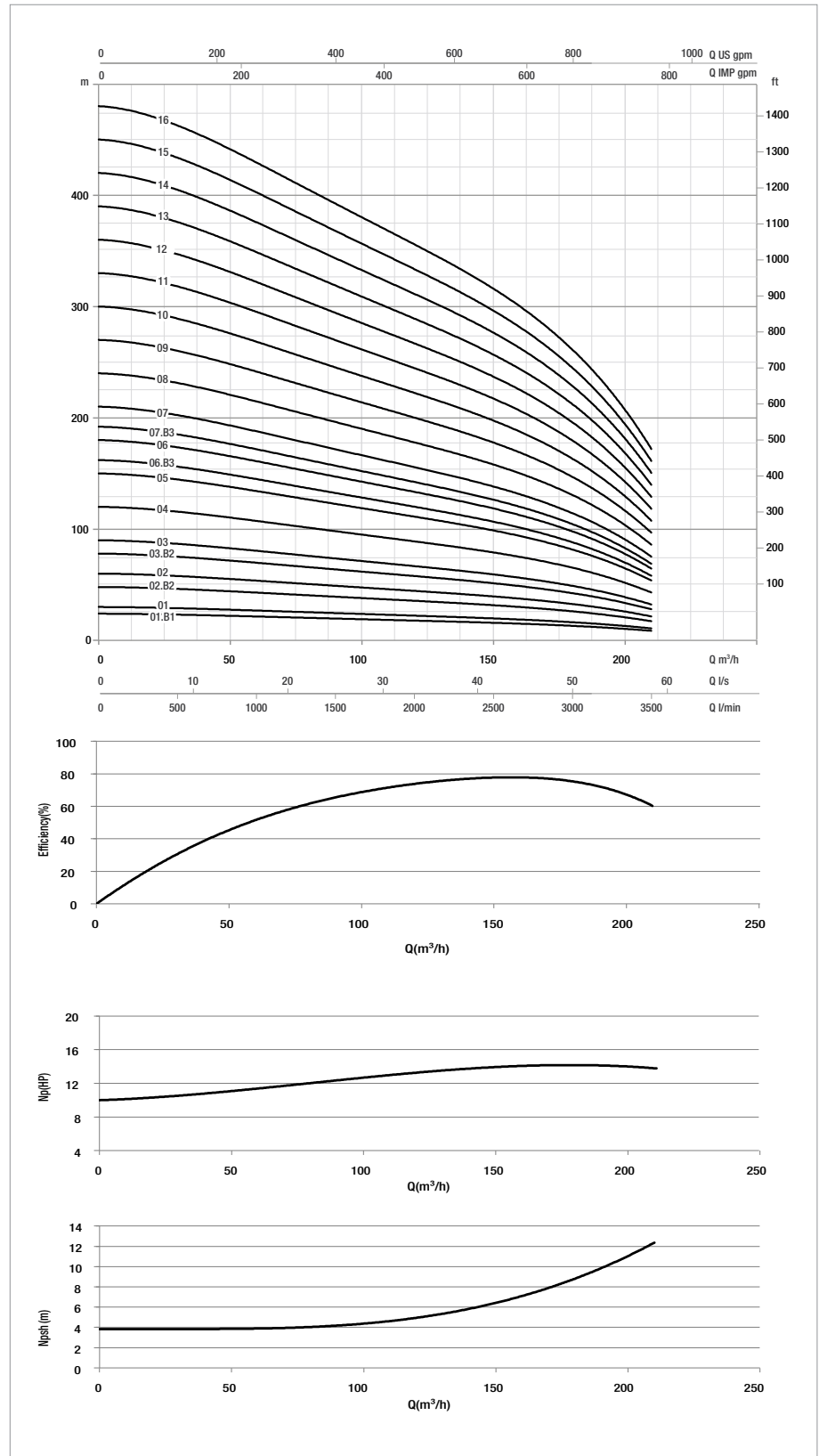
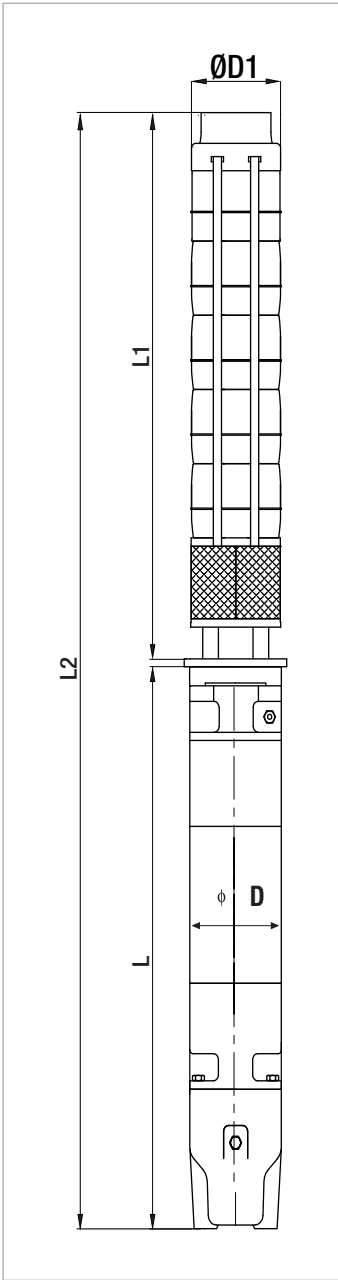

The performance curves are based on the kinematic viscosity values = 1 mm²/s and density equal to 1000 kg/m³. Curve tolerance according to ISO 9906.



TECHNICAL DATA

Flow rate maximum: up to 290 m³/h

Head up to: 385 m

Maximum immersion depth: depending on the motor

Type of pumped liquid: clean, free from solid or abrasive substances, non-viscous, non-aggressive, non-crystallized and chemically neutral. The version in AISI 316 stainless steel is also suitable for aggressive solutions and/or salt water

Maximum sand quantity: 50 g/m³

Liquid temperature range: from 0°C to +50°C (depending on the motor)

Maximum operating pressure: depending on the motor

Maximum ambient temperature: 30°C (50°C available on request).

Flanges, thread: 6"

Pump maximum diameter: 247 mm

Impeller/s material/s: pressed AISI 304 stainless steel

Protection class: IP 68

Single phase power input: not available

Three phase power input: 3x230 V 50 Hz / 3x400 V 50 Hz

Power cable (m) and plug: depending on the motor (all the motor are without the power plug)

Possible type of installation: fixed in vertical position. Horizontal installation permitted by removing the non-return valve and installing a cooling jacket (check the applicability of the motor for horizontal use in the dedicated section)

Special versions on request: molded AISI 316 stainless steel construction (impellers and pump body) for aggressive water applications, delivery ports with NPT standard

10" semi axial multi-impeller submersible pump in molded AISI 304 or AISI 316 stainless steel, designed for pressurization, lifting water from wells, gardening and irrigation in commercial building service and irrigation also in agriculture. Ideal for installation in wells.

CONSTRUCTION FEATURES OF THE PUMP

Diffusers, impellers, supports, delivery and suction made entirely of pressed AISI 304 stainless steel or AISI 316. Impellers balanced and keyed to the shaft with a conical coupling, specially developed to guarantee: easy assembly, avoid malfunctions due to vibrations during rotation and reduce operating noise. Shaft driven by water lubricated bearings. The diffuser geometry facilitates the expulsion of sand particles with the pumped liquid and limits the infiltration of water between the stage. Integrated non-return valve to reduce localized pressure drops. Stainless steel filter applied to the suction mouth to prevent the entry of dissolved solid bodies. Delivery port threaded according to the GAS standard. Different types of impeller are available to guarantee the best efficiency at different flow rates and models up to 10 impellers to cover a wide range of heads.

CONSTRUCTION FEATURES OF THE MOTOR

Coupling with 6" or 10" motors depending on the power required by the hydraulic system:

- 6GF: 6" submersible encapsulated motor
- TR6: 6" submersible rewindable motor
- TR8: 8" submersible rewindable motor
- TR10: 10" submersible rewindable motor

For operation with the variable frequency drive, refer to the specifications of the coupled motor.

For hydraulic systems in AISI 316 stainless steel, we recommend coupling with motors made of AISI 316 or DUPLEX stainless steel (check availability of the selected model).

PERFORMANCE RANGE

The performance curves are based on the kinematic viscosity values = 1 mm²/s and density equal to 1000 Kg/m³. Curve tolerance according to ISO 9906.

GRAPHIC SELECTION TABLE

50 Hz - 2900 r.p.m.

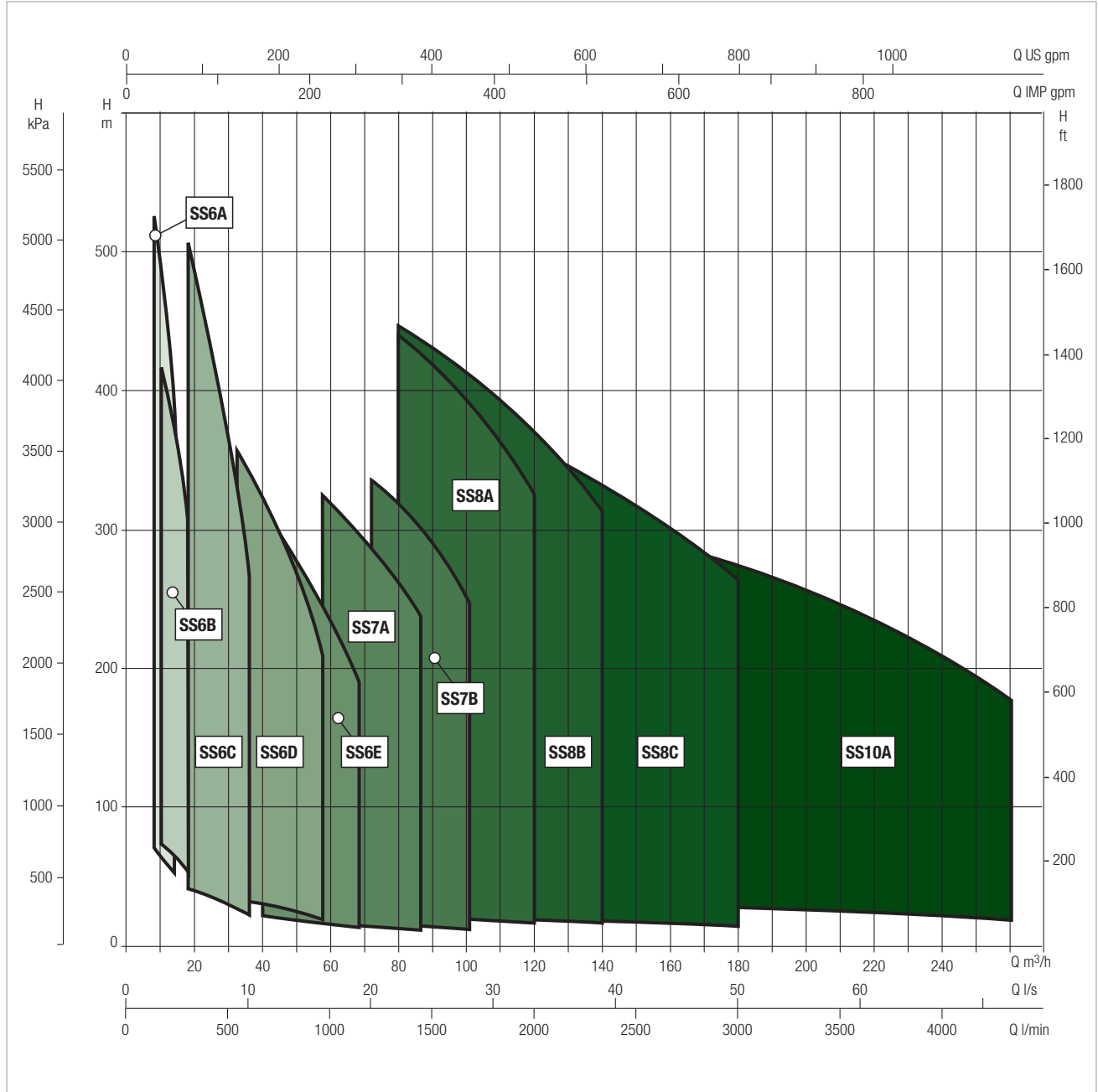

MATERIALS

N.	PARTS	MATERIALS
1	SUCTION CASE	STAINLESS STEEL (AISI 304L)
2	FILTER	STAINLESS STEEL (AISI 304L)
3	SUCTION CASE WEAR RING	BRONZE (ASTM B145-4A)
4	PUMP SHAFT	STAINLESS STEEL (AISI 420)
5	COLLET	STAINLESS STEEL
6	IMPELLER WEAR RING	STAINLESS STEEL (AISI 304)
7	IMPELLER	STAINLESS STEEL (AISI 304L)
8	DIFFUSER	STAINLESS STEEL (AISI 304L)
9	INTERMEDIATE BEARING	RUBBER
10	DIFFUSER WEAR RING	RUBBER
11	NUT FOR STOP RING	STAINLESS STEEL (AISI 304L)
12	BEARING	RUBBER
13	SHAFT STOPPER	BRONZE (ASTM B145-4A)
14	VALVE	STAINLESS STEEL (AISI 304)
15	DISCHARGE CASE	STAINLESS STEEL (AISI 304)
16	TIE ROD	STAINLESS STEEL (AISI 304L)
17	CABLE GUARD	STAINLESS STEEL (AISI 304)
18	TIE ROD NUT	STAINLESS STEEL (AISI 303)
19	NAME PLATE	STAINLESS STEEL (AISI 304)

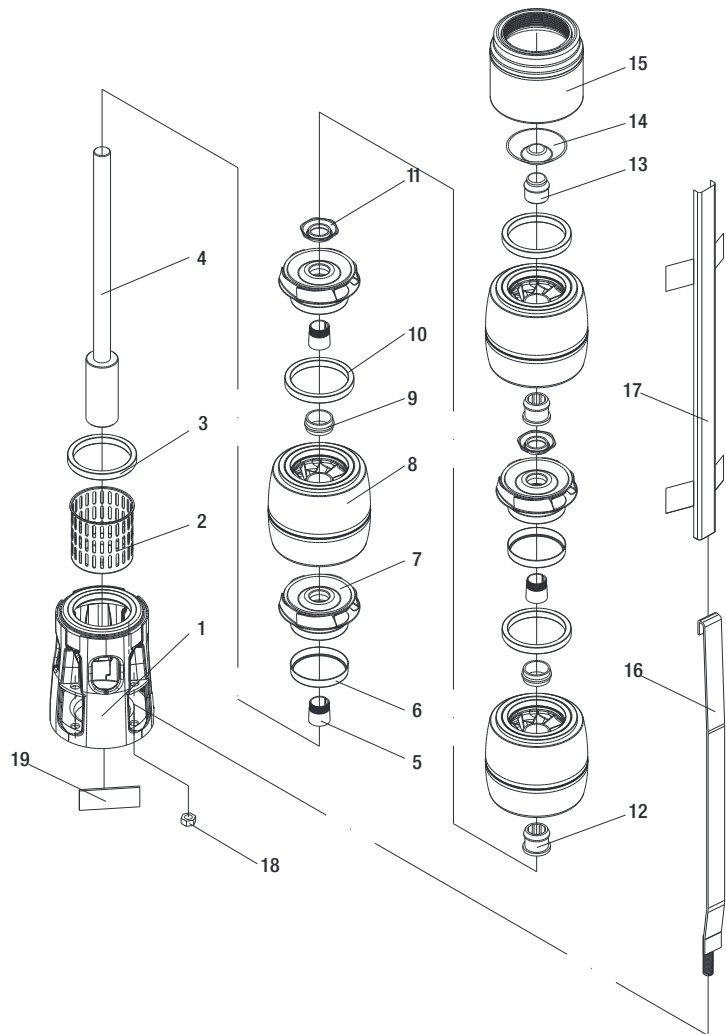

- Denomination index: (example)

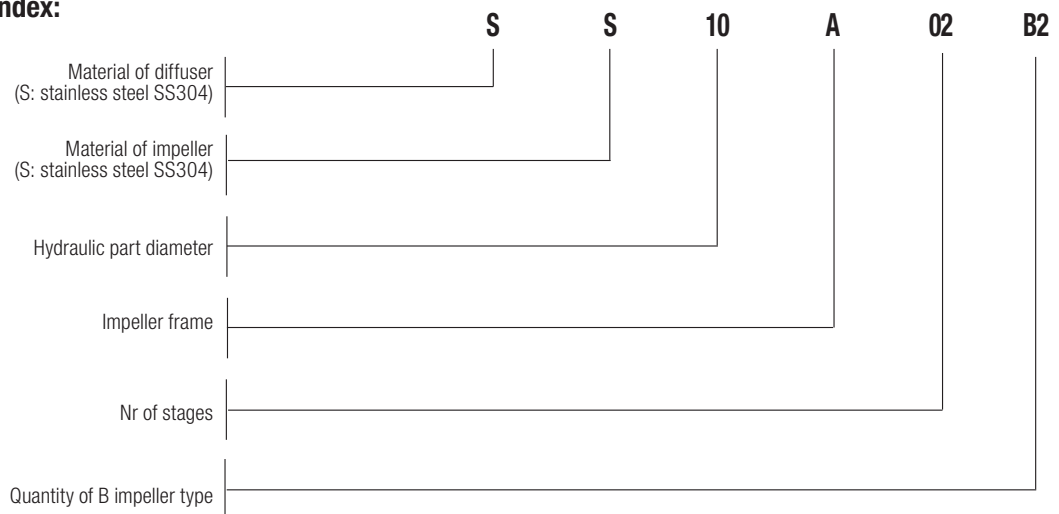

PERFORMANCE 50 HZ - 2 POLES

MODEL	ELECTRICAL DATA		HYDRAULIC DATA											STANDARD MOTOR COUPLING
	P2 NOMINAL		Q=m ³ h	0	50	100	140	180	200	220	240	260	290	
	kW	HP	Q=l/min	0	833,3	1666,6	2333,3	3000	3333,3	3666,6	4000	4333,3	4833,3	
SS10A 01.B1	15	20	H (m)	29	27	25	22	20	19	18	16	15	11	6"
SS10A 01	18,5	25		39	36	33	30	27	25	24	22	19	15	6"
SS10A 02.B2	30	40		58	54	49	44	40	37	35	32	29	22	6"
SS10A 02	37	50		77	72	66	59	53	50	47	44	39	30	6"
SS10A 03.B3	45	60		87	81	74	66	59	56	53	49	44	34	8"
SS10A 03.B1	55	75		106	99	91	81	73	69	65	60	53	41	8"
SS10A 03	63	85		116	108	99	89	80	75	71	65	58	45	8"
SS10A 04.B2	75	100		135	126	115	103	93	88	82	76	68	53	8"
SS10A 04	75	100		155	145	132	119	106	100	94	87	78	60	8"
SS10A 05	92	125		194	181	165	148	133	125	118	109	97	75	8"
SS10A 06	110	150	232	217	198	178	159	151	141	131	117	91	8"	
SS10A 07	132	180	271	253	231	207	186	176	165	152	136	106	10"	
SS10A 08	147	200	310	289	264	237	212	201	189	174	156	121	10"	
SS10A 09	170	230	349	325	298	267	239	226	212	196	175	136	10"	
SS10A 10	190	260	387	362	331	296	265	251	236	218	195	151	10"	

ELECTRICAL DATA AND DIMENSIONS

MODEL	MOTOR *	ELECTRICAL DATA				HORIZONTAL INSTALLATION	L2 mm	L mm	L1 mm	D mm	D1 mm	TOTAL WEIGHT kg
		P2 NOMINAL		In A	OPERATING BY INVERTER							
		kW	HP									
SS10A 01.B1	6GF	15	20	33,4	●	●	1580	786	794	141	247	105
	TR6	15	20	32	○	●	1771	977	794	144	247	121
SS10A 01	6GF	18,5	25	41	●	●	1655	861	794	141	247	113
	TR6	18,5	25	39	○	●	1831	1037	794	144	247	124
SS10A 02.B2	6GF	30	40	61,5	●	●	2021	1051	970	141	247	144
	TR6	30	40	65	○	●	2162	1192	970	144	247	165
SS10A 02	6GF	37	50	79,3	●	●	2151	1181	970	141	247	157
	TR6	37	50	80	○	●	2262	1292	970	144	247	168
SS10A 03.B3	TR8	45	60	92	○	●	2417	1270	1147	192	247	243
SS10A 03.B1	TR8	55	75	109	○	●	2497	1350	1147	192	247	258
SS10A 03	TR8	63	85	126	○	●	2637	1490	1147	192	247	284
SS10A 04.B2	TR8	75	100	145	○	●	2913	1590	1323	192	247	313
SS10A 04	TR8	75	100	145	○	●	2913	1590	1323	192	247	313
SS10A 05	TR8	92	125	177	○	●	3329	1830	1499	192	247	370
SS10A 06	TR8	110	150	213	○	●	3735	2060	1675	192	247	431
SS10A 07	TR10	132	180	257	○	●	3721	1870	1851	237	247	544
SS10A 08	TR10	147	200	300	○	●	4098	2070	2028	237	247	619
SS10A 09	TR10	170	230	348	○	●	4424	2220	2204	237	247	670
SS10A 10	TR10	190	260	405	○	●	4780	2400	2380	237	247	721

* **6GF motor:** 6" encapsulated water-glycol-filled motor with stator immersed in thermosetting insulating resin
TR motor: 6-8-10" water-filled rewindable motor

●	Allowed
○	Only PE2 + PA version

SS10A

SUBMERSIBLE PUMPS

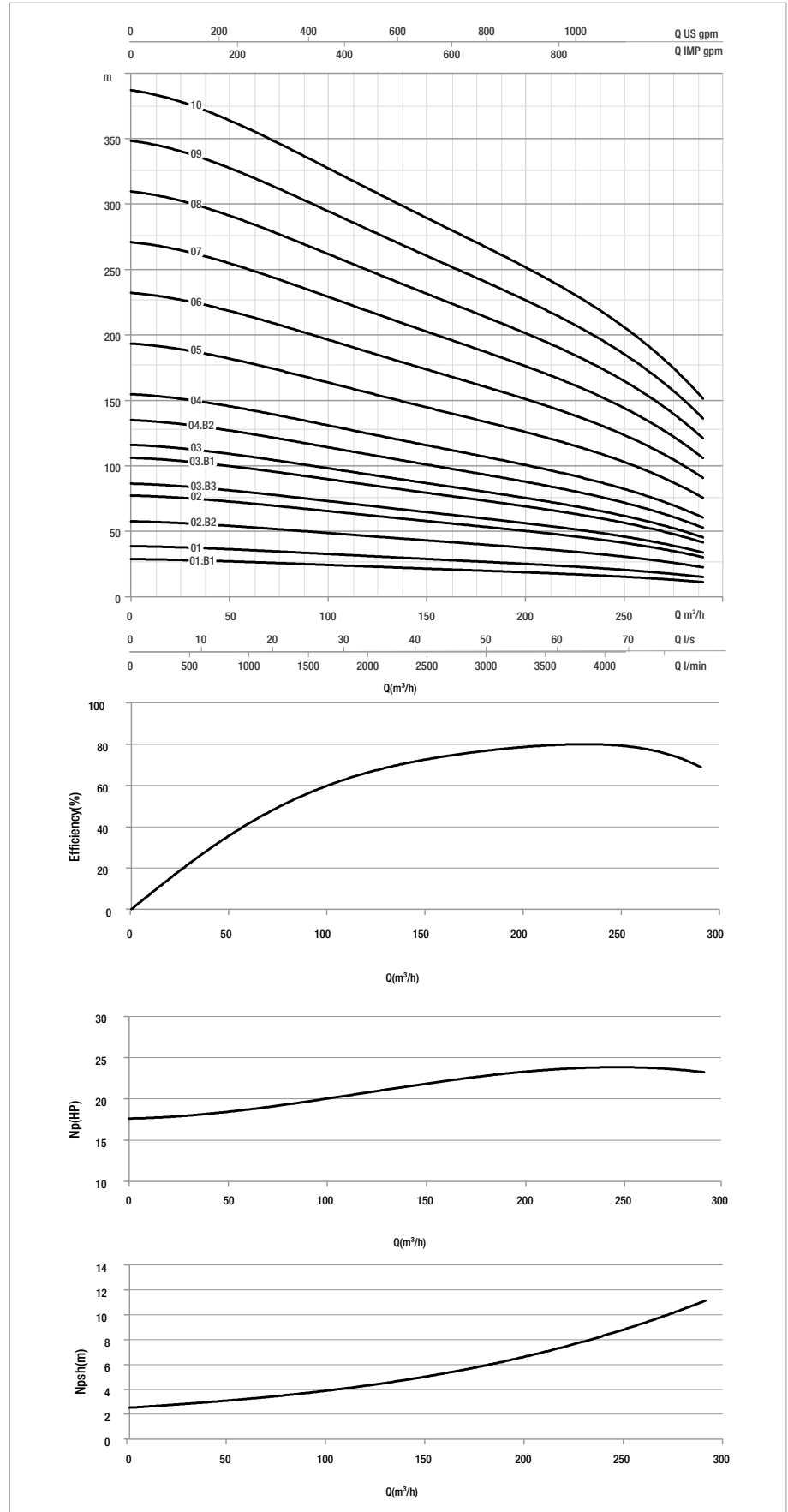
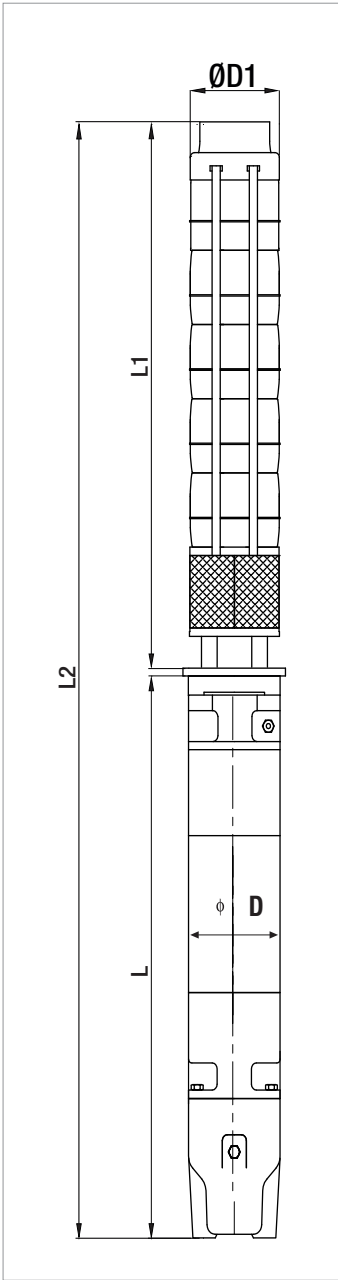

The performance curves are based on the kinematic viscosity values = $1 \text{ mm}^2/\text{s}$ and density equal to $1000 \text{ kg}/\text{m}^3$. Curve tolerance according to ISO 9906.

DAB
PUMPS SELECTOR

On-line product selection



DAB PUMPS LTD.
Unit 6 Gilberd Court
Newcomen Way, Severalls Park
CO4 9WN
Colchester
ordersuk@dwtgroup.com
Tel. +44 0333 777 5010



DAB PUMPS IBERICA S.L.
Calle Verano 18-20-22
28850 - Torrejón de Ardoz - Madrid
Spain
Info.spain@dwtgroup.com
Tel. +34 91 6569545



DAB PUMPS DE MÉXICO, S.A. DE C.V.
Av Amsterdam 101 Local 4
Col. Hipódromo Condesa,
Del. Cuauhtémoc CP 06170
Ciudad de México
Tel. +52 55 553 2621



DAB PUMPS BV
'tHofveld 6 C1
1702 Groot Bijgaarden - Belgium
info.belgium@dwtgroup.com
Tel. +32 2 4668353



DAB PUMPS HUNGARY KFT.
H-8800
Nagykanizsa, Buda Ernő u.5
Hungary
Tel. +36 93501700



DAB PUMPS SOUTH AFRICA (PTY) LTD
Twenty One industrial Estate,
16 Purlin Street, Unit B, Warehouse 4
Olifantsfontein -1667 - South Africa
info.sa@dwtgroup.com
Tel. +27 12 361 3997



DAB PUMPS B.V.
Statenlaan, 4
5223 LA, 's-Hertogenbosch
Nederland
info.nl@dabpumps.com
Tel. +31 416 387280



DAB PUMPS POLAND Sp. z o.o.
Ul. Cieslewskich 35K
03-017 Warszawa - Poland
sprzedaz@dabpumps.com.pl



DAB PUMPS (QINGDAO) CO. LTD.
No.10 Xindong Road
Jiulong Town,
Jiaozhou City
266319 Qingdao (Shandong) - China
sales.cn@dwtgroup.com
Tel. +86 400 186 8280



DAB PUMPS FRANCE SAS
Tour Ariane, Paris la Défense 9
5, Place de la Pyramide
92800 Puteaux - France
info.fr@dabpumps.com
Tel. +33 (0)6 79 63 05 46
+33 (0)7 89 01 53 35



DAB PUMPS INC.
3226 Benchmark Drive
Ladson, SC 29456 - USA
info.usa@dwtgroup.com
Tel. 1- 843-797-5002
Fax 1-843-797-3366



DAB PUMPS OCEANIA PTY LTD
426 South Gippsland Highway,
Dandenong South VIC 3175 - Australia
info.oceania@dwtgroup.com
Tel. +61 1300 378 677



DAB PUMPS GMBH
Am Nordpark 3
D - 41069 Mönchengladbach - Germany
info.germany@dwtgroup.com
Tel. +49 2161 47388-0
Fax +49 2161 47388-36



DAB PUMPS CANADA INC.
333 Bay Street, Suite 4600, Toronto,
Ontario, M5H 2S5, - Canada
orders@dwtgroup.ca
Tel. 1-833-322-7867



PT DAB PUMPS INDONESIA
Satrio Tower lantai 26
unit C-D, Jl. Prof. Dr. Satrio Kav. C4,
Kel. Kuningan Timur, Kec. Setiabudi, Kota Adm.
Jakarta Selatan, Prov. DKI Jakarta. - Indonesia
Tel. +62 2129222850